

People's Democratic Republic of Algeria
Ministry of Higher Education and Scientific Research
Mentouri University Constantine 1
Faculty of Letters and Languages
Department of letters and English Language

N° ordre : 45/D3c/2018

N°serie :09/Ang/2018

***Generic Analysis of Instructional Discourse in
User Manuals of Technical Equipments and
Machines***

Thesis Submitted to the Department of Letters and English Language

For the Degree of 'Doctorat LMD' in Applied Language Studies

Presented by: Hichem BRIGHET

Supervised by: Prof. Hacene HAMADA

BOARD OF EXAMINERS

Présidente : Prof. HAROUNI Zahri. Université Mentouri Constantine 1

Encadreur : Prof. HAMADA Hacène. Ecole Normale Supérieure de Constantine

Membre : Prof. LABED Nacif. Université Mentouri Constantine 1

Membre : Prof. BELOUAHEM Riad. Université Mentouri Constantine 1

Membre : Prof. ABDELLATIF Nawel. Université de Sétif 2

- 03 MAI 2018 -

Dedication

This work is dedicated to the memory of my late father who did not live long enough to see this achievement.

To my caring, loving, and supportive mother. Without her support, this work would have never been accomplished. Words cannot express how grateful I am to my mother's sacrifices that she has made on my behalf. Her prayer for me was what sustained me that far.

This dedication also extends to my beloved brothers and sisters.

To my colleagues and friends.

Acknowledgments

First and foremost, I would like to express my sincere gratitude to my supervisor Professor Hacene Hamada for his guidance, encouragement and patience through the writing of this thesis. I was sincerely honoured to work with him. I would like to thank him for helping me grow as a researcher.

I would like to express my appreciation and thanks to my friends and colleagues, namely Mr. Sami Debbabi, Mr. Dendane Boujamaa, and Mostefa Talhi for their help and support in completing this work.

Special thanks are due to the examining board, namely, Prof. HAROUNI Zahri. Université Mentouri Constantine 1, Prof. HAMADA Hacène Ecole Normale Supérieure de Constantine, Prof. LABED Nacif. Université Mentouri Constantine 1, Prof. BELOUAHEM Riad. Université Mentouri Constantine 1, Prof. MEBARKI Zahia . Université de Sétif 2, and Prof. ABDELLATIF Nawel. Université de Sétif 2, for reading the work and for the valuable comments and observation that will help polishing this work.

Abstract

The present research aims to investigate the influence of discourse community on the communicative purposes of the genre. The study seeks to reveal how a change in the communicative purpose affects genre membership. It explores the genre of instructions in the technical field, focusing namely on user and service manuals. The research sheds light on the genre of instructions as it addresses a wide range of audience who are members of a discourse community, varying from a general to a very specific one, and explains how technical information, represented by instructions, is conveyed to different types of audience, namely the laymen and technicians respectively. Hence, it is hypothesized that a change in the discourse community will lead to a change in the communicative purposes of the communicative event. In other words, user manuals will have different communicative purposes by changing the community to which they are addressed. The methodology is based on a corpus-based analysis of a sample of thirty user and service manuals representing different products that are available in the Algerian context. First, the moves used to structure the genre are identified manually. Then, the data is processed using different text analysis tools to determine the linguistic features including sentence type and the lexical sets used to construct the identified moves. The results obtained from both types of manuals are compared to find out the changes resulting by moving from a general to a specific discourse community. The study reveals that the change of the discourse community could affect the communicative purpose of such genre. However, it does not lead to a completely different set of communicative purposes; hence, the two types of manuals share some of the communicative purposes because they share, to a great extent, the same pattern of moves that reflects the intended communicative purposes. In addition, the differences between the two types of manuals make it clear that the change that may occur at the level of communicative purpose does not necessarily affect the genre class and thus does not give us a different kind of genre.

Keywords: genre, discourse community, communicative purpose

List of Abbreviations

EAP: English for Academic Purposes

ELT: English Language Teaching

EOP: English for Occupational Purposes

ESP: English for Specific Purposes

EST: English for Science and Technology

Imp: imperatives

M1: model one

M2: model two

Ng: negative imperatives

Nv: negative imperatives using never

P: pattern

SFL: Situational Functional Linguistics

List of Tables

Table 1. Searle' six categories of indirect directive (Malcolm, 1977,p25).....	26
Table 2. The main defining characteristics of genre and register.....	60
Table 3. Register features and marker, genre markers (adopted from Biber et al 2009).....	67
Table 4. frequency of the identified moves in 15 user manuals	141
Table 5.Frequency of the Identified Moves in Fifteen Manuals.....	161
Table 6.Keywords in safety information extracted from user manuals	177
Table 7.Nature and frequency of the first part of the introductory sentence.....	185
Table 8.Infinitive phrase patterns frequency	186
Table 9. Verbs and tense used in safety instructions introductory sentence.....	189
Table 10. Vocabulary profile of safety instructions in 15 user manuals.....	190
Table 11.Sentence types of safety instructions in user manuals.....	193
Table 12.Sentence types frequency.....	194
Table 13.Frequency of imperative including negative imperative.....	195
Table 14.Sentence type in installation instructions.....	206
Table 15.Sentence type frequency in 132 sentences.....	207
Table 16.Vocabulary profile of installation instructions.....	208
Table 17.Analysis of operating instructions according to sentence types	215
Table 18.Sentence type frequency.....	216
Table 19.Vocabulary profiler of operating instructions of 15 manuals	217
Table 20.Sentence type frequency in maintenance instructions.....	223
Table 21.Maintenance instructions vocabulary profiler	225
Table 22.Sentence types of troubleshooting instructions	230
Table 23.Vocabulary profiler for troubleshooting instructions	234
Table 24.Sentence type used in warranty	238
Table 25.Vocabulary profiler of warranty/guarantee information.....	240

Table 26. Vocabulary profiler for sentences used as first move in service manuals	247
Table 27. Sentence type in safety instructions of service manuals.....	252
Table 28. Vocabulary profiler of safety instructions in service manuals	254
Table 29. Vocabulary profiler of specifications in service manuals.....	258
Table 30. Sentences' structure defining manuals'' audience.....	262
Table 31. Vocabulary profiler of sentences indicating manuals' audience	263
Table 32. Vocabulary profiler of product description and features.....	266
Table 33. Sentence type of installation instructions	268
Table 34. Vocabulary profiler of installation instructions.....	269
Table 35. Sentence type of operating instructions.....	271
Table 36. Vocabulary profiler of operating instructions.....	273
Table 37. Sentence type of disassembly instructions.....	277
Table 38. Vocabulary profiler of disassembly instructions	278
Table 39. Frequency of sentence types in troubleshooting instructions.....	281
Table 40. Vocabulary profiler of troubleshooting instructions.....	283
Table 41. Vocabulary profiler of user and service manuals	285
Table 42. Sentence types of safety instructions in user and service manuals.....	286
Table 43. Sentence types of installation instructions in user and service manuals.....	288
Table 44. Sentence types of operating instructions in user and service manuals	290
Table 45. Sentence types of troubleshooting in user and service manuals.....	292
Table 46. Shared and unique moves of both types of manuals.....	318
Table 47. Lexical sets of the shared moves between user and service manuals.....	323
Table 48. Average of the lexis used in the shared moves	326
Table 49. Sentence types of shared moves in user and service manuals.....	327

List of Figures

Figure 1. Hutchinson and Waters' ELT Tree (1987).....	40
Figure 2. Trimble's EST rhetorical process chart	44
Figure 3. Widdowson notion of discourse, text and textualisation.....	47
Figure 4. Members and discourse community relationship.....	61
Figure 5. Situational characteristics of register and genre.....	72
Figure 6. Swales' Moves in Research Articles Introductions.....	75
Figure 7. Bhatia's model for promotional genre.....	76
Figure 8. Text-first approach for genre analysis (Swales and Askehave 2001)	82
Figure 9. Context-first approach for genre analysis (idid 2001).....	83
Figure 10. Text before using Text Stripper.....	123
Figure 11. Text after using text stripper.....	123
Figure 12. Example of vocabulary profiler analysis of safety instructions	124
Figure 13. Different instances of the first move 'read and keep the manual'	162
Figure 14. Different instances of the move 'thanking the customer'	170
Figure 15. Different instances of 'safety information' move	173
Figure 16. Words closeness and relationship to the notion of safety.....	181
Figure 17. Possible models using infinitive phrase in safety instructions	188
Figure 18. Different instances of 'product features' move	197
Figure 19. visual of vacuum cleaner.	201
Figure 20. name of parts separate from visual.....	201
Figure 21. Visuals used to explain installation process	205
Figure 22. Troubleshooting using two patterns	232
Figure 23. Patterns used to express 'read and keep' move in service manuals	246
Figure 24. product features in user manuals of vacuum cleaner.....	294
Figure 25. product features in service manuals	294

Figure 26. product features in user manuals of dishwasher.....	295
Figure 27. product features in service manuals	295
Figure 28. specifications in user manuals of tumble dryer	297
Figure 29. specifications in service manual of tumble dryer.....	297
Figure 30. thanking the customer in user manuals	299
Figure 31. warranty in user manual of vacuum cleaner.....	300
Figure 32. clean and maintenance in user manual of dishwasher.....	302
Figure 33. using only verbal to explain maintenance instructions in LCD TV user manual..	303
Figure 34. Using only visuals to explain maintenance instructions in Iron user manual	303
Figure 35. samples of specifying audience in service manuals	305
Figure 36. servicing instructions in microwave and water heater service manuals.....	307
Figure 37. testing tips from servicing instructions in service manual of tumble dryer	308
Figure 38. disassembly instructions in service manuals of tumbler dryer and microwave oven.	310
Figure 39. schemas in service manual of vacuum cleaner.....	311
Figure 40. diagrams in service manuals of dishwasher.	312
Figure 41 . exploded view in service manual of washing machine.	314
Figure 42. Interrelated relationship of audience, purposes and moves.....	316

Contents

Introduction.....	1
1. Statement of the problem.....	1
2. Aim of the study and research questions.....	2
3. Hypothesis:	3
4. Research method and tools	4
5. Structure of the thesis.....	6
Chapter one: From Language to Discourse analysis and EST Discourse	11
Introduction.....	11
1.1. Language form and function	11
1.2. Semantics	13
1.3. Pragmatics	18
1.4. Discourse analysis	27
1.4.1. Text :	28
1.4.2. Discourse:.....	29
1.4.3. Context:.....	30
1.4.4. Elements of Discourse:	30
1.4.4.1. Cohesion:.....	31
1.4.4.2. Coherence.....	32
1.4.5. Discourse of Instructions.....	34
1.5. English for Specific Purposes	35
1.5.1. The Demands of a Brave New World.....	35
1.5.2. A Revolution in Linguistics	36
1.5.3. Focus on the Learner	36
1.6. ESP Definition.....	37
1.7. English for Science and Technology	39
1.8. Scientific English.....	41
Conclusion	48

Chapter two: Genre analysis and genre approaches	49
Introduction.....	49
2.1. Genre analysis	49
2.2. Main approaches to genre analysis	51
2.2.1. New rhetoric approach	51
2.2.2. The Functional Approach	52
2.2.3. Situational Approach.....	56
2.2.3.1. Participants:.....	61
2.2.3.2. The relationship among participants:	62
2.2.3.3. Channel:	62
2.2.3.4. Production circumstances:	63
2.2.3.5. Setting:.....	63
2.2.3.6. Communicative purpose:.....	64
2.2.3.7. Topic	65
2.2.3.8. Register features and Markers versus Genre markers.....	65
2.3. Discourse Community	70
2.4. Moves and rhetorical strategies.....	74
2.5. Communicative Purpose and Genre Membership	77
Conclusion	84
Chapter three: Technical writing and manuals	85
Introduction.....	85
3.1. Technical writing	85
3.2. Technical manuals	88
3.3. Different types of manuals	90
3.4. The Importance of Technical Manuals.....	91
3.5. Typical technical documents.....	93
3.5.1. Proposals	94
3.5.2. Reports	94
3.5.3. Instructions	95
3.6. Genre analysis and Technical Communication	95
3.7. Manuals' Structure.....	97
3.7.1. Appearance	97
3.7.2. Content.....	99
3.7.2.1. Information	99

3.7.2.2. Language	100
3.7.2.3. Word choice	101
3.7.2.4. Sentence structure	102
3.7.2.5. Imperative	105
3.8. Readability	106
3.9. Usability	107
Conclusion	108
Chapter four: research methodology and moves analysis framework	109
Introduction.....	109
4.1. Understanding corpus	109
4.2. Mode of communication.....	111
4.3. Corpus based Vs corpus driven.....	112
4.4. Data collection regimes	112
4.4.1. Monitor corpus approach.....	113
4.4.2. Sample corpus	113
4.4.3. Opportunistic corpora	114
4.5. Use of annotated vs unannotated corpora.....	114
4.6. Total accountability vs data selection	115
4.7. Monolingual versus multilingual corpora	116
4.8. Description of manuals' corpus	118
4.8.1. Data collection	119
4.8.2. Method and tools.....	120
4.9. Moves identification in user and service manuals	125
4.9.1. Moves identified in user manuals	125
4.9.1.1. <i>LG Vacuum Cleaner</i>	125
4.9.1.2. <i>LG Air Conditioner</i>	126
4.9.1.3. <i>Beko Tumble Dryer</i>	127
4.9.1.4. <i>Braun Kitchen Hood</i>	128
4.9.1.5. <i>Philips Hair Dryer</i>	129
4.9.1.6. <i>Braun Steam Iron</i>	130
4.9.1.7. <i>LG LCD TV</i>	131
4.9.1.8. <i>Samsung Refrigerator</i>	132
4.9.1.9. <i>Water Heater</i>	133
4.9.1.10. <i>Samsung Washing Machine</i>	135

<i>4.9.1.11. Sony Handy Camera</i>	136
<i>4.9.1.12. LG Microwave Oven</i>	137
<i>4.9.1.13. LG Dishwasher</i>	138
4.9.1.14. Brother sewing machine	139
4.9.1.15. Delonghi Heater	140
4.9.2. Moves Identification in Service Manuals of Household Equipments	142
<i>4.9.2.1. LG Dishwasher Service Manual</i>	142
<i>4.9.2.2. LG LCD TV</i>	143
<i>4.9.2.3. Microwave oven</i>	144
<i>4.9.2.4. Samsung Air Conditioner</i>	145
<i>4.9.2.5. Samsung refrigerator</i>	147
<i>4.9.2.6. LG washing machine</i>	148
<i>4.9.2.7. Garland Induction Cooker</i>	150
<i>4.9.2.8. Daeivoo DVD Player</i>	151
4.9.2.9. Bradford White water heater	152
4.9.2.10. LG tumble dryer	153
4.9.2.11. Brother sewing machine	154
4.9.2.12. Philips steam iron	156
4.9.2.13. Samsung mobile phone	157
4.9.2.14. Sony handy cam	158
4.9.2.15. LG vacuum cleaner	159
Conclusion	161
Chapter five: Linguistic Features of Moves in User and Service Manuals	162
Introduction	162
5.1. Linguistic features of moves in user manuals	162
5.1.1. Read and keep the manual for future reference	162
5.1.2. Thanking the customer for buying the product	170
5.1.3. Safety information	173
5.1.4. Safety instructions	182
5.1.5. Product features and description	196
5.1.6. Installation instructions	203
5.1.7. Operating instructions	209
5.1.8. Cleaning and maintenance	218
5.1.9. Troubleshooting	226

5.1.10. Warranty.....	235
5.2. Linguistic features of moves in service manuals	243
5.2.1. Read the manual before servicing the product	243
5.2.2. Safety instructions or precautions	249
5.2.3. Specifications	255
5.2.4. Audience of the manual	259
5.2.5. Product description/features.....	264
5.2.6. Installation instructions.....	267
5.2.7. Operating instructions.....	270
5.2.8. Disassembly instructions	274
5.2.9. Troubleshooting	279
Conclusion	283
Chapter six : Comparison of moves and summary of results.....	284
Introduction.....	284
6.1. Shared moves	284
6.1.1. <i>Read the manual.</i>	284
6.1.2. Safety instructions.....	285
6.1.3. Installation instructions.....	287
6.1.4. Operating instructions.....	289
6.1.5. Troubleshooting	290
6.1.6. Product features	293
6.1.7. Specifications	296
6.2. Moves unique to user manuals.....	298
6.2.1. <i>Thanking the customer</i>	298
6.2.2. <i>Warranty</i>	299
6.2.3. <i>Clean and maintenance</i>	301
6.3. Moves unique to service manuals	304
6.3.1. <i>Audience</i>	304
6.3.2. <i>Servicing instructions</i>	306
6.3.3. <i>Disassembly instructions</i>	308
6.3.4. <i>Schemas and diagrams</i>	311
6.3.5. <i>Exploded view</i>	313
6.4. Summary of Results and Findings.....	314
6.4.1. Comparison of moves in user and service manuals.....	318

6.4.2. Lexis of shared moves in user and service manuals.....	323
6.5. Discussion according to research questions.....	331
<i>6.5.1. Questions one and two</i>	<i>331</i>
<i>6.5.2. Question three</i>	<i>332</i>
<i>6.5.3. Question four.....</i>	<i>334</i>
6.6. According to Hypothesis.....	336
6.7. Limitation of study and suggestions for further research.....	334
Research Implications	343
Conclusion	347
General Conclusion.....	348
Bibliography.....	354

Appendices:

Appendix I: 15 User Manuals

Appendix II: 15 Service Manuals

General Introduction

1. Statement of the problem

As users of language, and depending on our needs, we come across different types of writings that provide us with some necessary information that helps us as readers to accomplish the intended tasks. Technical writing is, undoubtedly, one of these writings that we have experienced in our everyday life as it is meant to provide us with technical information. Thus, in a way or another, we have used such writings either by giving directions to foreigner, emailed a co-worker and explained a complex task, or read a recipe or even instructional manuals to use given equipment or machines. Nowadays, the need for technical writing is more demanding than it used to be due to the advances in technology and economy. The need for technical writings to satisfy the society's needs led to the development and emergence of different kinds of genres. In Algeria, it is nowadays necessary for all educational, economic, business, marketing and advertising professionals to improve their communication skills in English technical writing. The former represents an access key to the international economic and business exchange arena. Promoting Algerian products and services worldwide depends to a great extent on the English technical writing communication skills. However, to the best of our knowledge, there are no initiatives that investigated this field of research in our context, exception may be done for Research Laboratories in translation lead by Professor Farouk Bouhadiba in Oran and a few research teams that focused on translation in the field of humanities and social sciences in Constantine.

In this research, we attempt to explore fundamental structure of technical genre, namely how technical documents, representing such genre, are organized to successfully communicate technical information to the reader/user. In addition, the research sheds light on the relationship between the discourse community and genre conventions that

shape and identify the genre. Such conventions are known and shared by discourse community members who have common goals generally referred to as communicative purpose. In fact, a communicative purpose is a very important concept within genre studies. Many of the studies conducted on genre use communicative purpose as a distinctive criterion to classify genres. The latter is based on Swales' (1990) works on genre in which he views communicative purpose as a 'privileged criterion'. In other words, the internal structure, or schematic structure, of the genre is determined and shaped according to the communicative purpose it serves. Inspired by Swales' (1990) notion of genre, many scholars, including Bhatia (1993), adopted the functional approach that is based on classifying genre according to communicative purpose or their function.

2. Aim of the study and research questions

This study aims to explore a particular kind of genre, namely technical manuals. Thus, it seeks to investigate such genre at different level of proficiency. That is, it takes into consideration technical documents devoted to professional and non-professional, including user and service manuals. Thus, analyzing such kind of genre helps to understand its theoretical and practical aspects, which make it possible to:

-Distinguish the genre features of user and service manuals that are provided with some technical products (some products are already manufactured in Algeria, probably to be exported later);

-Suggest some implementation ideas to teach technical writing for students who would seek jobs that require technical writing skills in Algeria and elsewhere; thus they need to be aware of the different conventions used to convey technical information through genres as technical manuals

As genre is not only affected by communicative purpose but also by moves structure, the latter is shaped by the communicative purpose that the genre serves. In other words, variation at the level of moves may affect greatly the category of genre; hence, we can say that moves represent the structure and shape of the genre. Such assumption trigger many questions about genre structure and genre membership including:

1. Is it possible to address the professional users/readers with the same genre used for non-professionals?
2. Would they recognize this communicative event as a genre even if they do not belong to the same community members? (Non-professionals).
3. Do user manuals devoted to the layman have the same communicative purpose as those used to address the professional users as technicians?
4. What kind of genres can we have when there is a change of the communicative purposes?

3. Hypothesis:

Since this research is based on genre studies that assign genre membership according to the communicative purpose it serves, we advanced the following hypothesis as an attempt to investigate on one hand, the influence of discourse community on communicative purpose of the genre. On the other hand, the role of communicative purpose as well as moves structure in attributing genre membership.

A change in the discourse community will lead to a change in the communicative purposes of the communicative event. In other words, user manuals will have different communicative purposes by changing the community to which they are addressed. In turn, changing communicative purpose will lead to the emergence of new

genre because the moves used to convey them will be affected and hence the structure of the genre.

4. Research method and tools

The research is based on the analysis of a corpora consisting of 30 manuals representing user and service manuals of household equipment. Since there are two types of manuals involved, they are analysed separately. That is, we analyse user manuals first, consisting of 15 manuals, after that we consider service manuals. The analysis of data goes through two main steps. First, we need to analyse the moves used in each type of manuals. Second, we identify the linguistic realisation for each identified move. In order to determine linguistic features characterizing each of the identified moves, the segments of texts that represent each move are analysed at the level of sentence types and vocabulary.

In the first step, the moves are identified, by going through the manuals one by one from beginning to end. Since manuals are already structured using section and sub-sections, identifying where the move stops and where the other starts was rather straightforward. However, we cannot entirely rely on them because these sections may include different types of information that require careful attention, on the part of the research, to determine which move they need to be assigned to. The moves are classified according to the order in which they were identified within each manual. After that, the obtained moves from each manual are compared with each other to determine the most frequent moves used in user manuals. Once the most frequent moves are identified, we used them as a pattern of moves that represent user manuals. The same method of identifying and classifying moves is used for service manuals. Next, when we finish the identification of moves in both types of manuals, we compare

the results in order to determine if there are any similarities and differences in the pattern of moves used in user and service manuals.

In the second step, the moves are analysed to reveal the linguistic realisation of each move. This step is more concerned with textual analysis of the data. In fact, it is based on two parts including the analysis of sentence types and the analysis of vocabulary. Analysing sentence types is done using annotation. In other words, the identifying sentence types are given codes within the corpus as follows: **i-** for imperative sentence, **d-** for declarative sentence, **r-** for interrogative, and **c-** for conditional. Annotating the corpus in such a way helps us to determine the frequency of each type of sentences within the corpus. By doing so, we can find out which sentence type is mostly used to convey the moves in question. The same method is followed while dealing with service manuals. Once the results are obtained from both types of manuals, namely user and service manuals, they are compared to see whether they have the same distribution of sentence types or not.

With that being said, part two of the analysis is devoted to the nature of vocabulary used to represent each of the identified moves in the manuals. However, to accomplish this part of the analysis we need the interference of the computer since there is a large number of words to be processed. Therefore, the manuals are converted to file texts to prepare them for the analysis through specialised software. In addition, this step enables us to get rid of visuals hence the software processes only raw texts.

Once all manuals are converted into TEXT files, they are ready to be processed by the first tool known as 'Compleat text stripper'. It is worth noting that 'compleat' is not a spelling mistake of 'complete' but it is the name of this program. The role of this tool is to refine the input texts of the manuals into raw data that will be processed later with

another tool. To put it differently, it purifies the data from such elements that can occur within the texts as returns, punctuation, figures, numbers and spaces. The next tool is known as 'Vocabulary Profiler'. This tool is very useful as it analyses the manuals' vocabulary according to different categories including, academic words, scientific words, content and function words.

Last but not least, the results obtained from analysing the thirty manuals are compared so that to reveal the similarities and differences between both types of manuals. This consideration helps us to know what kind of moves user and service manuals use to communicate technical information to the user/reader communities.

5. Structure of the thesis

The thesis is structured in six chapters that represent the theoretical and practical aspects of the research; three chapters are devoted to the theoretical framework and three chapters present the practical part of the research.

The first chapter provides a background of language form and function including the development of discourse analysis and the emergence of EST discourse. It gives an overview and explains the use of language as a means of communication to fulfil the various tasks we perform in everyday life as users of language. In fact, whatever the tasks we want to accomplish, using language, they tend to be of two types: transactional and interactional. The first type, which is transactional, is mainly about transmitting or exchanging information between people. For instance asking for directions, in the context of a foreigner who seeks information to get to his destination and the one that gives him directions is only concerned with transmitting the necessary information correctly. On the other hand, interactional tasks are those that involve the use of information, not for the sake of exchanging them, but rather to socialize with other

people. Thus, describing the weather as hot or cold for someone sitting next to you is not about giving him information that he does not know, but it is a way of breaking the ice and starting a conversation. Therefore, using language to communicate depends primarily on what we want to do with it. Taking this into account, the chapter goes on to explain the importance of meaning in communication; hence, words alone may not be sufficient to deliver the intended meaning appropriately. Thus, it describes meaning from two perspectives namely from a semantic and pragmatic point of view. Moreover, discourse analysis interprets meaning by going beyond the sentence level. Thus, it involves extra factors as context and participants. Within this scope, the chapter sheds light on the directive or instructional discourse that is more significant to the present study. Such kind of discourse is meant to instruct people how to accomplish a given task. Thus, it may address the community of professionals as technicians and engineers as it may also address the laymen community. Moving to more specific fields and discourse types, the chapter provides, first, an overview of ESP (English For specific purposes) including its emergence and development. Second, it introduces EST (English for Science and Technology). In addition, it discusses scientific English and discourse with reference to Trimble' (1985) rhetorical techniques and functions. The former refers to notions as space, order, causality and results that provide a framework in which information can be presented. The latter gives the discourse its intended communicative function using description, classification, definition, instructions, verbal and visuals.

The second chapter deals mainly with genre analysis and genre approaches. It provides a definition of the term 'genre' in its broader sense as it includes Swales' (1990) workable definition of the term. Since this research is based on genre analysis, the chapter provides a full interpretation of Swales' (1990) definition and explains the main key words used in his definition such as communicative event, communicative

purpose and discourse community. Many scholars following Swales' (1990) notion of genre, including Bhatia (1993) and Martin (1997), use communicative purpose as the primary criterion for genre classification. For them, communicative purpose is a "privileged criterion". Since they share the same notion of classifying genre according to its communicative purpose, they are said to represent the functional approach. In fact, this approach is one of the main three approaches known in the field of genre. They are the functional approach, situational approach and linguist approach. In this chapter, a thorough description of these approaches is provided including the main known figures that adopted such approaches. Therefore, the chapter provides a clear distinction between register and genre analysis while discussing systematic functional linguistics. In spite their differences, genre and register have a common ground, which is analysing texts according to situational features.

The third chapter deals with technical writing and technical manuals. It provides a definition of technical writings as it explains the process of writing technical documents. The chapter shows that technical writing is not an easy task because it does not involve only writers but also designers, illustrators, editors and translators. Thus, it is a collaborative work of people from different fields whose objective is to provide the necessary information needed in technical field. As technology advances, writers in this field try to adopt technology to users through different types of documents. In fact, technical writing covers a wide variety of writings as technology education, traditional technical writing and technology marketing. In addition, the documents produced through such writings differ according to the communicative purposes they serve; they include procedural, evaluative, persuasive and investigative documents. As far as this research is concerned, more attention is given to the first type of documentations, namely procedural documentations, since they include the writing of technical manuals.

Therefore, the chapter gives a full description of appearance and structure of technical manuals and shows that manuals differ in their type and size. Depending on the audience they address, they vary from general, as in the case of user manuals, to very specific as in the case of technical manuals. In addition, manuals come in different forms as they may be a leaflet or a thick booklet. The structure of the manual is discussed through its appearance, including features as paper size, graphics, paragraph spacing, and contents. The latter describes how information is organised and presented to the user/reader, taking into account the language, word choice, and sentence structure. Since presenting information to the user/reader is of great importance, the chapter provides a discussion of readability and usability of the manuals.

Chapter four is a description of the methodology and tools used to collect and analyse the data. In addition, it provides the analysis of moves in user and service manuals. First, it gives a brief description about the nature of corpus, explores and justifies the choice of the research method adopted and the research tools used in the collection of data, and highlights the different procedures to be followed in the analysis of the data. Second, it presents the analysis of the data, which consists of 30 user and service manuals. The chapter shows the identified moves in both types of manuals and discusses the use and importance of each of the identified moves. To avoid any confusion, the identified moves are provided along with the type and name of the manual. Thus, it gives first the moves identified in user manuals then those identified within service manuals.

Chapter five is concerned with the linguistic features used in the identified moves in both types of manuals. It discusses each of the identified moves according to sentence types and lexical sets. The chapter shows the use of ‘Vocabulary Profiler’, which gives

clear image about the nature of the vocabulary used to express the identified moves in user and service manuals.

In chapter six, the results gained from the analysis of both types of manuals are compared so that to determine the similarities and differences between the two types. The comparison is conducted on the basis of the identified moves in each type of the manuals, namely user and service manuals, and the linguistic features that represent them. Furthermore, it gives a summary of results and findings from the analysis and comparison of user and service manuals, and distinguishes the similarities and differences obtained from comparing both types of manuals. The results are summarised using tables so that to give a clear image about the unique and shared moves that shape both types of manuals as well as the linguistic features through which these moves are conveyed.

Chapter one: From Language to Discourse Analysis and EST Discourse

Introduction

In this chapter, we will discuss language use development in communicating meaning. Although language has different functions that determine the type of meaning we want to convey, the interpretation of the intended meaning needs the interference of other factors as context. In this regard, the chapter provides an overview of how meaning is perceived in different fields including semantic, pragmatics and discourse analysis. In addition, it considers meaning in very specific fields as EST. Thus, it gives a description of English for science and technology then it sheds light on the nature of EST discourse.

1.1. Language form and function

Language is indispensable means of communication in our life. We all use language, but we do not use it in the same way, hence we have different tasks to accomplish via language. Each use of language depends on what we want to communicate or what we want to do with the language. Some of us use language to exchange information; others use it to make social relationships. From these varying uses of language, two views of language emerged: they are transactional and interactional.

According to Brown and Yule (1983), the transactional and interactional views of language are general distinction of language functions including: representative, expressive, referential and emotive. Thus, the transactional language, as called by linguists, is mainly used to transmit “factual or propositional information” (Lyons 1977:32). Language in this view is a kind of “message oriented”, the primary concern of the speaker/writer, here, is the transmission of the information i.e. the intended information must be received by the hearer/reader in a correct way. In other words, the

speaker/writer has to make sure that the recipient of the information gets the appropriate message. For instance, a policeman gives directions to a stranger, a shopkeeper gives information about a given products. Following the transactional view, the sender of the information (in this case, the policeman and the shopkeeper) must be clear when he transmits the information to the receiver (in this case, the stranger and the customer).

In spite of the fact that language has a communicative function, namely when transferring the information, sociolinguists shift their attention to the social relationships made by the language. For them language is mainly used for interactional affairs. That is, as human beings we are social creatures, we cannot live without socializing with the others (Valli and Lucas, 2000). Thus, talking to someone sitting next you on the bus is not a kind of exchanging information, but rather socializing. The conversational analysts also support this view. With reference to them, our everyday conversations are characterized by the interpersonal use of language, which means that when you say to someone “it is cold” you do not seek to inform him about the weather, but rather to show him that you are friendly.

All in all, regardless of the activity that we want to accomplish with language, whether we want to exchange information or we want to socialize, in both cases we use language. Thus, when we say ‘language’, what comes to our minds is that words, sounds and grammar. Knowing this, we may ask how this simple structure can make us perform transactional or interactional activities. To answer this question we must first bear in mind that words, sounds and grammar alone cannot make us communicate on their own. Therefore, we need something else more than just words, sounds and grammar. In fact, we need meaning to make these elements of language useful in communication (Saeed, 2011). The term ‘meaning’ is very broad and needs the consideration of many aspects of language. The meaning of the words alone is not

sufficient for the interpretation of the sentences/utterances. In order to get the intended meaning we need to consider “context” because the literal meaning of the words is sometimes misleading. Hence, some words have multiple meaning, the consideration of context is very important to determine which meaning is intended by the speaker. So far, we used the term “meaning” without giving any definition of the term. This term is generally associated with the field of semantics, which is interested mainly in the study of meaning.

1.2. Semantics

In semantics, there is a much interest in “what words conventionally mean rather than what the individual speaker might want them to mean on a particular occasion” (Yule 2005:100). Dealing with meaning entails the distinction between two types of meaning, conceptual and associative meaning. The former refers to the literal meaning of the words, for instance the word ‘needle’ has a conceptual meaning as ‘thin, sharp, steal instrument’. In other words, the conceptual meaning of words may be linked to those definitions provided by the dictionary. The latter is the meaning that we associate to the words depending on our perception of the word, which means that the associative meaning differs from an individual to another (ibid). Thus, the previous example of the word ‘needle’ may have as an associative meaning as ‘pain, illness’ or ‘thread, knitting’.

Ogden and Richard published in 1923 a book entitled “the meaning of meaning” where they listed sixteen meanings of the term “meaning”. For instance, “I mean to be there tomorrow” is different from “thunder means a storm”. In the first sentence, the verb “mean” has the meaning of “intend” whereas in the second sentence it has the meaning of “sign” (Palmer 1981).

The following examples illustrate their range of use:

- 1) What is the meaning of sesquipedalism'?
- 2) I did not mean to hurt you.
- 3) He never says what he means.
- 4) She rarely means what she says.
- 5) Life without faith has no meaning.
- 6) What do you mean by the word concept?
- 7) He means well, but he's rather clumsy.
- 8) Fame and riches mean nothing to the scholar.
- 9) Dark clouds mean rain.
- 10) It was John I meant not Harry. (ibid)

Although the same term is used in each example, each of which has different interpretation from the other. In order to understand the meaning of the term 'mean' in each example we must substitute it with appropriate word so that to produce an equivalent sentence. Following this, the word 'intend' is more appropriate to be substituted for 'mean' in (2). The same notion of 'intend is suitable in (4), (6), (7), (10). However, in (5) the substitution would be 'significance or value', the same thing can be said for (8). In (1) the substitution with 'intend or significance' is not appropriate because such meaning will affect the meaning of the original sentence. Having said that, we notice that the meaning of words is determined by "the use of to which language is put in communicative situation" (Herman 1995:161). That is, the meaning of words depends on the use of the speaker/writer of such words to convey their meaning. Furthermore, words acquire their meaning within sentences; hence we do not produce words in isolation.

Talking about word meaning and sentence meaning lead us to consider two aspects of semantics these are sense and reference. Since semantic theory is based on

these two relations, namely sense and reference relations, it is worth mentioning that sense relations are related to word meaning and reference is related to sentence meaning. That is, sense refers to the relationship between the linguistic elements i.e. it is intra linguistic relation (Griffiths 2006). Dictionaries are best examples of sense relations since they provide the meaning of the word according to other words. In addition to that, reference is concerned with the relationship established between the linguistic elements and the non-linguistic world of experience. To make it clearer, sense relations focus on the structure of the language while reference relations are concerned with our experience of the external world.

In spite of the fact that semantics is based on both relations, sense and reference, some linguists tried to limit the scope of semantic to the study of only sense relations. Among these, Katz and Fodor (1963:176) argued, in their article “The Structure of a Semantic Theory”, that “semantic theory describes and explains the interpretive ability of the speakers by according for their performance in determining the number of readings of a sentence; by detecting semantic anomalies; by deciding upon paraphrase relations between sentences and by making every other semantic property or relation that plays a role in this ability”.

From this quotation, it is clear that in order to interpret a sentence one must take into consideration some elements including the number of readings of the sentence, semantic anomalies and paraphrase. Thus, according to Katz and Fodor (1963) semantic theory must explain such sentences as the following (Herman and Gruyter 1976:255):

- 1) His typewriter has bad intentions.
- 2) My unmarried sister is married to a bachelor.
- 3) John was looking for the glasses.

- 4) a-The needle is too short.
b-The needle is not long enough.
- 5) a-Many of the students were unable to answer your questions.
b-Only a few students grasp your questions.
- 6) a-How long did Archibald remain in Monte Carlo?
b-Archibald remained in Monte Carlo for some time.

From these examples we notice that they do not have the same semantic relations. Thus, anomalies sentence can be seen in (1) while (2), (3) are illustrations of contradiction and ambiguity respectively. Paraphrase is shown in (5). In addition to that, we notice that there is an exclusion of the settings of sentences i.e. there is no consideration of the external world. Thus, this view of excluding the setting of sentences is one of the traditional semantics hence the focus was on the vocabulary. However, semantics now is giving more attention to the meaning of the sentence, which means that to interpret the meaning of a sentence we need more than the total meaning of the individual words.

There are many aspects of language to consider while dealing with sentence meaning these are: prosodic meaning, grammatical meaning and propositional meaning (Lyons 1995). Prosodic is very important in considering the meaning of the sentence because any change on the emphasis given to words may alter the sentence meaning for instance consider this example: John has bought a red car/John has bought a red car. The emphasis that we attribute to words makes us define which words are of great significance in giving more information. If we emphasize the word car it means that we want to show that John has brought a red car and not a green one. In addition to that, grammatical meaning makes us determine the subject, verb and object of the sentence, which can be analyzed from a semantic angle; consider for instance, 'David read a book'. This sentence, from a grammatical point of view, consists of subject, verb and

object, but if we consider it from a semantic point of view we notice that we have an actor performing certain action in a given time (Lyons1995).

In spite of the fact that the meaning of a sentence is more than the meaning of the individual words together, many linguists prefer to exclude context in their analysis of sentence meaning. To make it clear, many reasons are behind the exclusion of context, we just mention some of them. First, the exclusion of context helps dealing with sentences that are anomalous or ambiguous hence if we “know the meaning of a sentence before we can use it in any given context, meaning is thus shown to be independent of context” (Palmer 1981:43). Second, dealing with semantics in terms of reference i.e. the external world means that we make the scope of semantics unlimited because we will include more than the meaning of words or sentences. For instance, ‘my typewriter has bad intentions’ ‘John was looking for the glasses’. If we consider these two sentences, we know immediately that they are cases of anomaly and ambiguity respectively (ibid). The question that raises here is that how do we know that? The answer is that from the additional information that comes from the external world. Katz and Fodor suggest that we can handle such sentences by “extension” (Hugoe 2001). They claim that those ambiguous sentences or what they call sentences that have two readings can be disambiguated by extending their meaning; for instance, consider “the bill is large”. In terms of Katz and Fodor this sentence has two readings because of the word ‘bill’. This sentence can be disambiguated if its meaning is extended to ‘...but need not to be paid’. It is worth mentioning that the ‘extension’ is made of the one possible meanings of the word ‘bill’.

Although some linguists prefer to exclude context from sentence meaning, it is quite convenient, to get the meaning of the sentence, to use other types of information that is considered as non linguistic because it makes the meaning of sentences more

understandable. The reason why we cannot limit the scope of semantics to only what is purely linguistics is that we always use our knowledge of the world to determine sentences as anomalous and ambiguous (ibid). For instance, we can determine that “John was looking for the glasses” is ambiguous from our knowledge of the world i.e. we know already that the word “glass” has two meanings “spectacle, drinking glass”.

Since we are dealing with the issue of context and the knowledge of the world, it is worth mentioning that this consideration leads us to consider another branch of linguistics which means that we go beyond semantics to include more than linguistic elements i.e. even participants are taken into consideration. Thus, we are going to consider pragmatics.

1.3. Pragmatics

Unlike semantics pragmatics is concerned primary with the intended meaning of language users rather than the literal meaning of words and sentences. Pragmatics is interested in the study of meaning in context. It seeks to explain aspects of meaning which cannot be found in the plain sense of the words or structures as explained by semantics (Virginia, 2003). For instance, the sentence ‘it is cold in here’ can be understood just as a statement, not more than that ‘there is cold in here’. However, if we want to understand what this sentence means, taking into consideration the context in which it occurs, we will find that this sentence can be a request rather than a statement. Thus, uttering this sentence in an appropriate context makes the hearer understand that you are asking him for instance ‘to shut the door’ or make something to help him. Therefore, pragmatics is an important area of study since it "allows us to investigate how this meaning beyond the words can be understood without ambiguity" (Ariel 2008:72). In other words, "pragmatics is all about meanings [...].Meanings are implied

and the rules being followed are unspoken, unwritten ones" (Keith, 2012:123). To put it clear, "pragmatics is the study of speakers meaning" (Yule 1996:3). This means that only pragmatics involves humans in the analysis of meaning. Analyzing meaning via pragmatics makes us explore many things than the mere literal meaning of the sentence; it helps investigating the listener ability to interpret the intended meaning conveyed by the speaker or the so called the invisible meaning. For instance let us consider the following example:

John: so, did you?

Marry: hey, who wouldn't?

At the first glance this conversation seems meaningless; hence, we do not know what is communicated between the participants. In order to understand this conversation one needs to know what the speaker wants to communicate (i.e. the intended meaning) rather than what the words mean by themselves (i.e. the literal meaning).

Unlike semantics, pragmatics seeks to explore meaning in context. Since speakers/writers use language to communicate things that are not stated explicitly, we need context to come to a much better understanding of what language users want to communicate. According to Grice (1975), the meaning of a conversation is not explicitly stated but rather implied. Therefore, the participants of the conversation must cooperate in order to communicate effectively. That is, they have to follow certain principles which he called "the cooperative principle". The basic components of this principle are four maxims of quantity, quality, relation, and manner (Grice 1975:45).

The maxim of quantity: make your contribution as informative as is required. Do not make your contribution more informative than is required.

The maxim of quality: do not say what you believe to be false. Do not say that for which you lack adequate evidence.

The maxim of relation: be relevant.

The maxim of manner: avoid obscurity of expression. Avoid ambiguity. Be brief, be orderly.

In order to understand, fully, the cooperative principle, let us consider the following example:

A: is there a pint of milk?

B: I'm going to the supermarket in five minutes.

Following Grice principle, we can notice that the above example lacks one maxim which is the relation maxim. That is, B's answer is not relevant to A's question. In spite of the fact that B's answer seems irrelevant, it does not mean that the conversation is none sense. For a native speaker, it is easy to infer the meaning that 'there is no milk and some will be bought shortly'. In Grice's terms 'a maxim has been violated and an implicature generated'. Hence, there is no one to one correspondence between the meaning of utterances and the linguistic forms. Grice's maxims are applied in most of our conversations because when we communicate with each other we assume that the speaker will provide the necessary amount of information and he will say the truth as he will be relevant and have clarity of expression (Yule 1996). In spite of that, as users of language, we do not apply these maxims hence there are cases where we flout or violate them. Depending on the situation in which we are involved, we may violate one of the maxims in order to communicate a particular meaning; for instance, consider the following example:

A: I hope you brought the bread and the cheese.

B: I brought the bread. (Yule 1996:40)

From this example it seems that B's answer lacks some of the information and so it violates the maxim of 'quality'. Although 'B' did not provide enough information, he is said to be cooperative because 'A' assumes that the cheese is not brought because 'B' does not mention it in his response. In addition, there are cases where the speaker mentions the maxims explicitly to show that he is aware of them and he is not flouting them. Quite often, this is done by expressions or marks known as Hedges. For instance consider these:

- As you probably know I'm afraid of dogs.
- So to cut a long story we grabbed our stuff and ran.
- I will not bore you with all the details but it was an exciting trip.(ibid:38)

These examples show that the speaker is aware of the maxim of quality. Usually speaker use such expression as *Oh, by the way, anyway*, to indicate that they have added some irrelevant information for instance to the discussion. Therefore, these expressions are marks of relation maxim. All in all, speakers are aware of the maxims; whether they respect them or violate them, there is always something communicated and it is up to the listener to infer the intended meaning.

Moreover, Grice (1975) introduced the notion of implicature. The term refers to the meaning associated to the words used by the speaker. Thus, implicature is about the meaning communicated by the speaker rather than the meaning of the plain words. The focus, here, is on what is communicated and not on what is said. For Levinson (2000:116), implicature is "inferences from the lack of further specification to the lack of need for it". This means that if we have little

information from the speaker we must come with the possible interpretations that go with the speaker intended meaning. Therefore, implicature is what the speaker intends to convey by the uttered words rather than the meaning of the words themselves. For instance consider the following:

- Andy: I think we should get a pet.
- Bess: cats are my favourite animals.

In the above example, 'B' communicated more than the words she used. In fact, she intended to mean that she and her friend should have a cat as a pet. In terms of pragmatics, she implicated the meaning of having "a cat as a pet".

According to Grice (1975), implicature is of two types, namely conventional and conversational. Conversational implicature includes three concepts as, generalized implicature, scalar implicature, and personalized implicature.

To start with, as its name indicates, conversational implicature has something to do with conversations and the intended meaning involved. Implicature in conversation is based on the maxims of the cooperative principle because in order to understand what is communicated in a given conversation we have to pay much attention to what is said and not to the meaning of the words as such. To make it clear, we consider the following:

a) Dobie: did you invite Bella and Cathy?

Mary: I invited Bella.

b) I'm studying linguistics and I have completed some of the required courses.

c) Rick: Hey, coming to the party tonight?

Tom: My parents are visiting.(Yule 1996:43)

The examples are instances of different types of implicature, which we are going to analyze separately. In the first example (a) the listener can easily infer the meaning that the speaker did not invite ‘Cathy’; hence, he only mentioned her name. So in order to infer this meaning the listener does not need additional information to help him because this is a general implicature. In the second example (b), the speaker used some specific words as “some” to indicate that he wanted to communicate certain information from the scale of values. Thus, there is generation of scalar implicature. The use of ‘some’ in this example means that the speaker has not completed all the required courses. Again, here we do not need additional information to infer the meaning of the speaker. Unlike the previous examples, example (c) shows that the listener must have some knowledge to infer the meaning that ‘his friend is not coming’ from the fact that his parents are visiting. The implicature generated in this example is called personalized implicature or simply implicature because it frequently occurs in every day conversation (Yule 1996).

However, the meaning of the utterance is, sometimes, derived from specific words that have a conventional meaning i.e. the meaning that is attributed to certain words and we all aware of it. To make the image clear consider this example:

- David arrived but John not.

One of the words that carry a particular meaning is shown on the above example. If we consider this example, we can see that there is a notion of contrast; hence, there is the use of the word “but” which implicates here that John did not arrive. The primary source of the implicature is the word ‘but’, thus this kind of meaning is called conventional implicature (ibid).

Grice's view about saying and meaning is not the only one hence there is another view that differentiates between saying and meaning. According to Austin (1962) when we produce utterances we mean more than the words we utter. However, Austin (1962) goes beyond Grice notion of implicature. He believes that utterances are not produced only to describe or to report, but they are used to perform actions such as : warning, promising, requesting, apologizing, etc... Following this consideration, he argues, in his book "How to do things with Words", that utterances tend to be of two types, constative and performative. The former refers to utterances that have a kind of acts bringing about some results. For instance consider the following: ' I name this ship "the Queen Elizabeth" (Austin, 1962:7). Obviously, this sentence is describing the 'naming' of the ship. However, in terms of speech acts, it is doing more than that as it is performing the action of naming the ship which implies baptizing (Coulthard 1977).

Furthermore, performatives cannot be judged as true or false, but felicitous i.e. appropriate. The latter indicates sentences that merely describe reality and thus they can be judged as true or false. For instance, 'the sun is a star', can be judged to be true or false since it describes a reality (Devitt and Hanely 2003). Whatever the actions performed by a given sentence, they are identified by three main characteristics. First, the locutionary act which is, simply, the act of uttering a certain sentence with a given meaning, namely the literary one. Second, uttering a sentence means that we have some meaning to convey and some actions to perform. This is the illocutionary act which is the significant element in the theory of speech acts. Third, when we perform an act through an utterance, we generally, intend to achieve a certain effect on the level of the addressee (Yule 1996). This effect refers to the perlocutionary act which includes such effects as: convincing, persuading, surprising, and so on. In order to have a clear cut

image about the three types of speech acts already discussed, we consider the following example:

1. Watch out the ground is slippery.
2. I will do my best to arrive in time.
3. I have just made some coffee.

In the above sentences, it is noticeable that the locutionary act is the literal meaning i.e. 'the ground is slippery', 'arriving in time', and 'making some coffee', respectively. In addition, (1) has the illocutionary act of warning, (2) has the illocutionary act of promising. The illocutionary act in (3) is inviting the addressee for some coffee. In (1) and (2), we can notice that perlocutionary acts coincide with the illocutionary ones i.e. their effects on the hearer is to warn and to promise, respectively. The perlocutionary act in instance (3) is making the hearer drink coffee.

It is agreed that, generally, the structure of the sentence indicates its communicative function. For instance, 'did you bring an umbrella?' shows, clearly, that there is a correspondence between the structure of the sentence, that is interrogative, and the communicative function that is a question. This direct relationship between the structure (interrogative) and the function (question) is described as a direct speech act (Yule 1985).

However, some sentences may not have a direct correspondence between the function and the structure. In this case the relationship between the structure and function of the sentence is called indirect speech acts (Yule, 1985). For instance consider the following: can you pass the salt? In this example, we have an interrogative structure which is normally used to ask a question. In fact, this sentence does not represent a question but

rather a request. Thus, there is an indirect relationship between the structure and the function. In English, indirect speech acts are considered to be more polite than direct speech acts (Yule,1996:56) for instance, ‘shut the door’, is less polite than ‘could you close the door please?’ The reason behind this is that the first sentence uses the imperative form which represents a direct speech act.

For Searle (1975), indirect speech acts are much interesting because they help understanding how hearers or readers arrive at a correct interpretation of performative sentences. This consideration makes him focus on indirect directives and classify them into six categories, shown in the following table.

Classification	Examples
Hearer’s ability	Can you pass the salt?
Future action of the hearer	Will you/are you going to pass the salt
The wish or wants of the speaker	I would like you to pass the salt
The desire of the hearer and willingness	Would you mind passing the salt?
Reasons for action	It might help if you pass the salt
Contains explicit performative not really a separate class	Can I ask you to pass the salt?

Table: 1. Searle’ six categories of indirect directive (Coulthard, 1977:25)

The table shows the suggestion made by Searle about the six categories of indirect directives. He called the first three types, in the table, preparatory, prepositional, and sincerely respectively. The two type (4) and (5), according to Searle, are used to represent the reasons for action (Coulthard; 1977:26). From the preceding classification, Searle comes to the following principles that serve in making indirect directive:

1. Asking whether, or stating about the hearer's ability i.e. the preparatory condition
2. Asking whether ,or stating the propositional content condition i.e. the future action
3. Stating the sincerely condition , that is the wishes of the speaker
4. Stating or asking whether there are reasons for doing the actions.

In spite of that, Searle argues that there is a need for “finding out when the utterance is just a question [...] and when it is a request” (Coulhard,1977:26). Such a statement makes us come to the idea that Searle's principles do not tell us, for instance, ‘can you pass the salt’ is to be interpreted as a question or as a request.

1.4.Discourse analysis

Discourse analysis was first introduced through the work of Zelling Harris (1952) on connected speech and writing. His interest aimed to analyse language beyond sentence level and to reveal the relationship between the linguistic and non-linguistic behaviour. In other words, he was primary concerned with understanding how people interpret the intended meaning from the situation they are in. Analysing language following this perspective was the starting point for many studies that sought to analyse language in context. However, the use of the term itself was a matter of disagreements among linguists. In fact, the term discourse analysis was meant to refer only to the spoken form of the language. As more studies were conducted and based on discourse analysis, the use of the term took a different direction to include both spoken and written forms of language. Thus, it is more concerned with the analysis of language, regardless of its form, and the context in which it is used.

In this respect, the boundaries of discourse analysis overlap with that of pragmatics; hence, both are interested in the interpretation of language users' intentions. In other words, they investigate meaning in terms of what is communicated more than that is said or written. However, discourse analysis "deals with larger communicative units as texts" (Widdowson 2004:1). Knowing that, such a communicative unit is, in fact, a controversial issue as what is to be represented with a text or a discourse. Therefore, to avoid any confusion, a distinction must be drawn between the terms text and discourse.

1.4.1. Text

The use of the term text generally refers to the written form of the language. However, since text is considered as a linguistic unit higher than the sentence, it extends to include written and spoken forms of language (Aziz and Latainwish 1999:53). As clarified by Cook (1989:185) "text is a form that represents written or spoken discourse". Brown and Yule (1983) explain the inclusion of spoken form in the use of text by suggesting that "text is a technical term [used] to refer to the verbal record of communicative act." Thus, the verbal records refer to the written representation of the oral language. In this regard, Crystal (1992:72) defines text as "a piece of naturally occurring spoken, written, or signed discourse identified for purposes of analysis. It is often a language unit with a definable communicative function, such as a conversation." According to him, text is simply an extended piece of language interpreted without context. In this sense, context refers to the non-linguistic and contextual features used in writing (John 1997). On the other hand, Nunan (1993:6) gives a more detailed definition of text. Following him, a text refers to 'any record of a 'communicative event'. The event itself may involve oral language or written language [...], a text or piece of discourse consists of more than one sentence and the sentences combine to form a

meaningful whole. The notion that a text should form a ‘meaningful whole –that is, convey a complete message- is commonsensical.’ It is clear, taking into consideration these views, that text is perceived as communicative unit higher than the sentence that includes written and spoken forms of language.

1.4.2. Discourse

In fact, the term discourse is used in a number of different ways; however, according to Nunan (1993), it needs to be distinguished from ‘text’. Thus, unlike text which is “divorced from its context of action and situation” (Malinowski 1935:8), discourse refers to the communicative event whether spoken or written in its context. According to Mey (1993:187) “discourse is different from text in that it embodies more than just the text, understood as a collection of sentences [...] discourse is what makes the text context-bound, in the widest sense of the term.” In this sense, discourse is defined following a pragmatic perspective, which implies that it is based on the analysis of meaning in context. As Brown and Yule (1983:26) clarify “Any analytical approach in linguistics which involves contextual considerations necessarily belongs to that area of language study called ‘pragmatics.’ “Doing discourse analysis” certainly involves doing “syntax and semantics”, but it primarily consists of “doing pragmatics” [...]. In discourse analysis, as in pragmatics, we are concerned with what people using language are doing, and accounting for the linguistic features in the discourse as the means employed in what they are doing.” That is, the interpretation of the intended meaning includes taking into account the contextual features used to communicate people’s intentions.

1.4.3. Context

In order to have an appropriate interpretation of the discourse, context is an important element that helps interpret the intended meaning of the discourse at hand. Its importance lies in the fact that it involves linguistic and non-linguistic factors, which represent the situation in which the discourse occurs. In other words, context, as defined by Nunan (1993:8), “refers to the situation given rise to the discourse and within which the discourse is embedded”. Knowing that, linguistic and non-linguistic are aspects of context that refer to the language surrounded by the discourse and the extra factors beyond language as participants, setting, the type of the event and its purpose and the background knowledge. It is worth explaining what these non linguistic aspects refer to. Participants refer to the people involved in the situation or in the discourse. Thus, they can be the listener and the speaker as in the case of spoken discourse, as they can also refer to the writer and the reader in the case of the written discourse. Setting refers to the physical situation including aspects as time and place. The communicative event represents such instances of language use as story, article, lecture and so on. The purpose of the event is the type of the information that the communicative event is trying to convey. The background knowledge is mainly the shared knowledge between people involved in the situation.

1.4.4. Elements of Discourse

The following elements of discourse are a major contributor in the interpretation of discourse. They are very important to consider while dealing with any type of discourse. They are namely known as cohesion and coherence of language.

1.4.4.1.Cohesion

It refers to the grammatical or lexical links that make sentences or texts hold together. As described by Baker (1992) they are “surface links” in the sense that we can identify and see them in the text. According to Halliday and Hassan (1976:2), “cohesive relationships within a text are set up where the interpretation of some element in the discourse is dependent on that of another”. According to them, such relationships are what give a text “texture” which binds the text together and distinguishes it from other aspects of language which is not a text. Halliday and Hassan made a significant work to determine different types of cohesive ties including, reference, substitution, ellipsis, conjunction, and lexical ties.

Reference is the use of words or units to refer to other entities in the text. There are two types of reference namely anaphoric and cataphoric. Anaphoric reference is used to refer backward in the text. Cataphoric reference is to point forward in the text. To make it clear, we consider the following examples:

Michael went to the bank. He was annoyed because it was closed.

When he arrived home, John went to sleep.

In the first example ‘he’ refers backward to ‘Michael’, while in the second example it refers forward to John. Although anaphoric and cataphoric reference are supposed to point backward and forward respectively, they both indicate reference to sentences within the text as shown in the mentioned examples. Thus, they are known as endophoric reference. However, if reference is used to point outside the text, it is known as exophoric reference.

Ellipsis refers to the omission of words or phrases that can be understood without having them to be repeated in sentences or texts. For instance, in “David played tennis and Peter football” it is clear that Peter ‘played’ football without using the verb ‘played’. While ellipsis is based on omission, substitution is to replace a word or a phrase in sentences or a text by another unit of language. For instance, consider, ‘I have a great time yesterday and I think Peter did to’. In this example, ‘have a great time’ is replaced with ‘did’. Conjunction refers to the use of cohesive items to create meaningful relationships between sentences or segments of texts. According to Halliday and Hassan (1976), there are four types of conjunction to be identified including additive, adversative, causal, and temporal conjunctions. Each of these types is used according to meaning of the relationship of sentences or text needed to be expressed. Thus, additive, when used, is meant to add or complete what the following clause is conveying. This kind of relation is usually achieved by using words as ‘and’. Adversative is to express meaning that is opposite or different from what is just written or said through the use of words as ‘but’. Causal indicates that the coming clause is a result or logical cause of the preceding one. It is expressed through words such as ‘because’ or ‘so’. Temporal is meant to express relations that express time by using words as ‘then’. Lexical ties refer to lexical items used in sentences or texts to form such relationships as repetition, synonymy, antonymy, and hyponymy.

1.4.4.2. Coherence

Although cohesion is identified through cohesive relations that are explicitly shown in the text, coherence is not that explicit. In fact, it is related to the reader ability to make sense of the text or sentences. In other words, the reader perceives that a given text is coherent by going beyond cohesive ties to consider extra factors as background

knowledge, culture, and experience. Thus, relying on these factors the reader assumes naturally that the text is coherent and interprets it based on such assumption (Brown and Yule 1983:66). Following Widdowson (1978), it is possible for a text to be coherent without “overt linguistically signalled” cohesion. Therefore, a text is not necessary coherent because of the different cohesive ties that link the sentences together. To illustrate the point, Brown and Yule (1983) suggested a scrambled set of sentences as follows:

A man in white clothes, who could be the surviving half-breed, was running as one does run when Death is the pace-maker. The white figure lay motionless in the middle of the great plain. Behind him, only a few yards in his rear, bounded the high ebony figure of Zambo, our devoted negro. An instant afterwards Zambo rose, looked at the prostate man, and then, waving his hand joyously to us, came running in our direction. They rolled on the ground together. Even as we looked, he sprang upon the back of the fugitive and flung his arms round his neck. (extract from Arthur Conan Doyle’s *The lost World*)

Even with the consideration of all the cohesive ties used in the above text, it is still very difficult to make sense of the text. As a result, it is just considered as a collection of sentences. Taking this into consideration, it is clear that cohesion alone is not enough to interpret the text as coherent. Sharing similar view with Brown and Yule (1983), Carrell (1982) states that coherence is not to be found within the text but rather outside. For her, coherence is not restricted to surface linguistic links that are not the cause but rather the effect of coherence (Celce and Olshtain 2000).

1.4.5. Discourse of Instructions

Whatever the type of discourse that one may deal with, discourse is produced to communicate a given piece of information. Thus, the primary concern in analyzing discourse is to reveal what is being communicated rather than restricting the attention to the linguistic features that construct the discourse (Hatch 1992). Approaching discourse from a communicative aspect helps to determine and identify the different communicative functions that are embedded within the discourse. In fact, such functions, when identified, express and convey the writers' intentions behind which the discourse is produced. Therefore, discourse reflects what writers are doing with language through the communicative functions they intend to convey including instructing, commanding, requesting, advising, and so on. With reference to speech acts theory, discourse tends to be of different types according to the acts they perform including directive discourse, expressive, commissive, and assertive.

As far as this research is concerned, more attention is given to the discourse of directives, also referred to as discourse of instructions. Knowing that instructional discourse is based mainly on instructions, its main objective is to instruct people so that to accomplish their intended tasks. In other words, they represent the 'how to' discourse, for instance how to use a dishwasher, how to repair a car, and how to make a given dish (Hatch 1992). Since people have different needs and purposes to achieve, instructions vary accordingly. Thus, instructions can be used to address professionals as technicians and engineers or they can address laymen. They are expressed through different steps that are meant to guide the user or reader to achieve the intended purposes regardless of the fact that they are professionals or laymen. In addition,

instructions are generally expressed through the imperative mood in order to make them clearer and more direct, without any room for ambiguity.

1.5. English for Specific Purposes

In order to understand English for specific purposes (ESP, henceforth), it is worth considering its emergence and development through time and its significant growth within the field of English Language Teaching (ELT, henceforth). Unlike other human activity, ESP was not meant to emerge because it was not a planned activity or movement. In fact, it is the result of different factors and changes that took place over a period of time. According to Hutchinson and Waters (1987), the emergence of ESP is justified by many reasons. However, among these, three main ones contributed truly to its existence. These reasons are identified as the following: the demands of a brave new world, a revolution in linguistics, and focus on the learner.

1.5.1. The Demands of a Brave New World

After the Second World War, there was a significant development in scientific, technical, and economic fields. Such growth and expansion eventually lead to the dominance of the world by two important domains of technology and commerce. This growth in technology and commerce required an international language that reflects the international activities in these domains. The English language developed as an international language because of the position and role of the United States in economy after the Second World War. Thus, the desire and the need to learn English was growing more and more hence it is considered as the international key to have access to technology and commerce. The demand to learn English, not for prestige or pleasure but as an international accepted language, gave birth to a new generation of learners who

want to satisfy their needs. A mechanic needs English to read instruction manuals, doctors need it to be up to date with the last development in the field of medicine, and a businessman needs English to sell his product at the international scale. As a result of this development, English became a kind of product leading to a great pressure on the language teaching perspectives to design effective courses with clear defined goals (Hutchinson and Waters 1987:6).

1.5.2. A Revolution in Linguistics

Since English was influenced by the development of the world, namely in technology and commerce, the need to learn English became bigger than ever. This demand to learn English made the courses to be designed according to specific needs. Such influence on the courses introduced new ideas in the study of language. Therefore, instead of the traditional description of language usage, attention shifted towards language use. Linguistic studies began to give more attention to the actual use of language in real communication settings. One of these ideas is to consider English as having different types according to context and the purpose to be achieved. For instance, commerce and engineering are two different fields and so the type of English needed to be taught in both fields differs accordingly. This assumption helped developing courses taking into consideration the linguistic characteristics of the field in which English is to be taught. In other words, “tell me what you need English for and I tell you the English that you need” (Hutchinson and Waters 1987:7).

1.5.3. Focus on the Learner

The need to learn English and the new ideas to design courses made the learners an important variable in the process of designing a course. The focus was on the learners

themselves in the sense that courses are designed to satisfy their needs and interests. Taking into consideration the needs of learners raised their motivation to learn. The relevance of the courses to the needs of the learners made the learning process faster and more effective. For instance, in biology, courses are designed to include texts mainly about biology. This consideration made the learners more motivated because they met their needs and interest, which made learning more effective.

So far, we discussed three of the main factors that contributed in the emergence of ESP. Still, there is not a clear image about the nature of ESP, whether it is a product that emerged due to the previously mentioned factors, or it is an approach to learning the English language. With that being said, in the ongoing discussion, we will present different views about how ESP is defined and perceived (Hutchinson and Waters 1987:8).

1.6.ESP Definition

The emergence and development of ESP was due to many factors including the worldwide development in the field of technology and commerce. ESP went through different stages of development which, in fact, focused on the linguistic aspects of ESP that is best described as language-centred approach. This development generated different views about ESP and its definition.

According to Hutchinson and Waters (1987), ESP is an approach instead of a product. They support their view with the fact that ESP is based on a simple question which is “why does this learner need to learn a foreign language? Need represents the reasons behind which the learner is learning the language. Once the need is defined, the language to be taught is determined accordingly. However, Strevens (1988) sees things differently in the sense that he defines ESP according to distinctive characteristics, more

particularly, absolute and variable characteristics. On the one hand, the absolute characteristics describe ESP to consist of English Language Teaching which is distinguished as being:

- Designed to meet specified needs of the learner.
- Related in content to particular disciplines, occupation and activities.
- Centred on language appropriate to those activities in syntax, lexis, discourse, and semantics.
- In contrast with general English (Dudley and Maggie 1998:3)

The variable characteristics, on the other hand, describe ESP as:

- May be restricted to the language learning skills to be learned.
- May not be taught according to any pre-ordained methodology. (ibid)

Another view about ESP worth considering is that of Robinson (1991), according to which ESP is ‘goal directed’ in the sense that it designs courses based on needs analysis. These kinds of courses are taught to adults in homogeneous classes according to their field of specialism and to a limited period of time. Following this view, ESP is more concerned with “what exactly students have to do through the medium of English” (Robinson, 1991:3).

Although the three presented views seem to differ from each other, they have a common ground for their definition of ESP. They all take into consideration needs analysis in the process of designing courses. However, among the three views, Strevens’ view is more extensive than the other two. In spite of that, Strevens’ characteristics might be confusing in terms of ESP is directly related to subject content. In contrast, teaching ESP is not necessarily related to content; however, it should include the

different concepts and activities of the broad discipline. For instance, English for Academic Purposes has to use problem-solving methodology of academic study regardless of its relation to the specific field that the students are learning.

1.7. English for Science and Technology

English for Science and Technology (EST, henceforth) contributed in the development of ESP as a separate area from ELT. In fact, most of the research conducted during the ESP emergence was in the field of EST, such as the work of Ewer and Latorre (1969), Swales (1971), Trimble (1976). This consideration helped in developing and designing ESP courses according to specific needs. Thus, at one point of time, EST and ESP were almost treated as synonymous. As Swales (1985:5) suggested, “English for science and technology has always set and continues to set the trend in theoretical discussion, in ways of analysing language, and in the variety of actual teaching materials”.

EST is a sub-branch of ESP, as Swales (1985:10) suggested: “EST is the senior branch of ESP while ESP is best described as the teaching of English not as an end in itself, but as essential means to a clearly identifiable goal”. Thus, EST, as described by Trimble (1985:5), is

...an area of written English that extends from peer writing of scientists and technically to the writing aimed at by the skilled technicians. Peer writing is exemplified by books and articles written by experts in one field for other experts in the same field or for experts in a related field. Skilled technicians are those who differ from engineers in the same field only that they lack equivalent training. (Trimble, 1985:5)

According to Broughton et al (1980:3), the wide area of written English covered by EST represents, in fact, “half of the world’s scientific literature”. In spite of the fact that EST

is a sub-branch of ESP, Munby (1978) pointed out to the ambiguous relation of EST and ESP as he stated, “the rationale for this distinction between EST and all other types of ESP courses is not clear [in fact], all ESP courses are EST oriented”. From another perspective, Hutchinson and Waters (1987) developed a diagram to explain the nature of EST in regard with other ESP branches. This diagram is known as the “ELT Tree”, which is fully shown in figure 1.

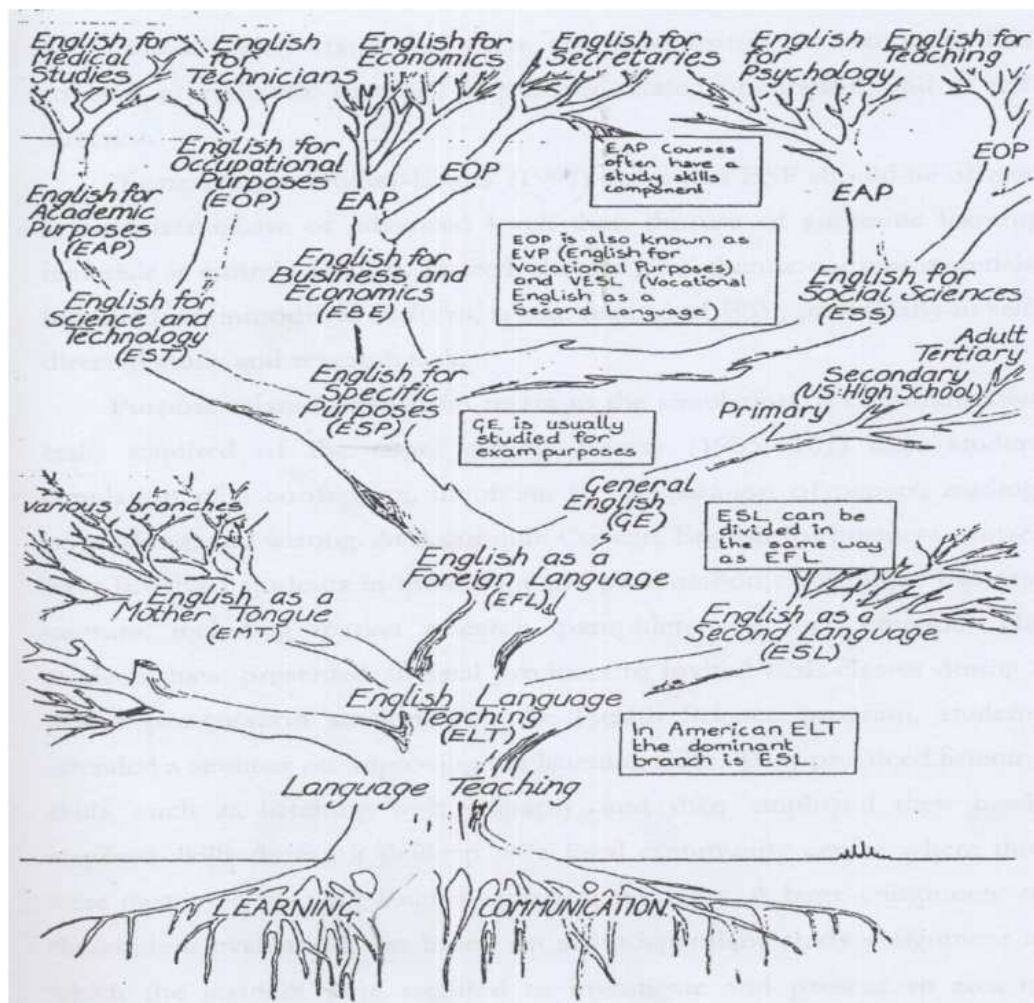

Figure 1. Hutchinson and Waters’ ELT Tree (1987)

As shown in ‘ELT Tree’, EST is broken down into sub-branches represented namely by English for Academic Purposes (EAP) and English for Occupational Purposes (EOP). Although EAP and EOP are presented as distinctive branches of EST, there is no clear cut distinction between them. As Hutchinson and Waters (1980:16)

argued that “people can work and study at the same time, it is also likely that in many cases the language learnt for immediate use in a study environment will be used later when the student takes up, or returns to a job”. Thus, on the one hand, the objectives of EAP are mainly summarised in study skills and communicative needs. The needs might include the desire to achieve a high standard of English and to attend a course of academic study. On the other hand, EOP is related to job training in the sense that the learner is to use his ability to learn the language in its context as a part of his job experience.

In addition to the fact that EST can be explained through its branches as EAP and EOP, Trimble (1985:2) claimed that EST is best explained through Larry Selinker’s definition. According to him EST is simply regarded as “the written discourse of English for Science and Technology” that extends to include even the “...informally written discourse found in trade journals and in scientific and technical materials written for the layman” (p6). Therefore, the next point to be discussed is the nature of scientific English and discourse.

1.8. Scientific English

Unlike the language of literature, scientific English is detached from any personal feelings or opinions. Thus, it is objective, accurate and precise. It is more concerned with facts and findings based on internal or external experiments. One of the early studies in scientific English was made by Flood (1957) who investigated the problem of vocabulary in the popularization of science. In his study, he tried to simplify science and make it more understandable to the general public. In addition, this study helped to identify new criteria to be considered in the selection of scientific vocabulary. Such criteria are very useful to determine the scientific words needed to explain different

concepts in the field of science. Therefore, accuracy in scientific writing is of great importance as Day and Sakaduski (2011:4) confirm, “all scientists must learn to use the English language with precision”.

Another significant study to investigate the characteristics of scientific English is that of Barber (1962) known as “some measurable characteristics of scientific prose”. In addition to vocabulary, Barber (1962) investigated sentence structure and verb forms. Such investigation revealed that the present simple in active and passive forms is the most frequent tense in scientific texts (Hirsh 2010). However, Strevens (1971:9) suggested the use of context in study of scientific English hence he noted “scientific and non scientific English share the whole of the English system and only when vocabulary is involved that slight differences arise”. Thus, the learner of foreign language must have specialized English vocabulary in addition to his general vocabulary. As far as scientific English is concerned, the specialized vocabulary is needed to express and convey such activities that usually take place in the scientific field as observation, formulation, hypotheses, experimentation and classification.

These activities are expressed through language, which entails the use of sentence connectives or as Yee (1975) call them ‘sequence signals’. These connectives play a significant role in connecting the different parts of the text together. As Yee (1975:6) explained, “they make explicit the sort of relationship that exists between the parts of a text, and often, the degree of explicitness of the relationship. They also function as transition words, and as such, contribute to the smooth flow of thought in written discourse”. Based on the analysis of eight EST texts, Yee (1975) identified fifteen categories of connectives taking into account their meaning. Thus, for instance, connectives, or sequence signals, as ‘that is’ and ‘namely’ are used for explanation. Widdowson (1979:257) agrees about the importance of connectives in texts as he

pointed out “ within each section there are stages which introduce new coherence relationships and these can be labelled by the overt clues which are used to mark them: ‘for instance’, making exemplification, ‘that is to say’, marking restatement, ‘however’, marking concession, ‘on the other hand’, contrast and so on”.

The importance of Yee’s (1975) connectives lies in the fact that they link or connect larger discourse units as paragraph. With reference to Trimble (1985), paragraph, in EST, is characterised by five rhetorical functions namely, description definition, classification, instruction, visual verbal relationships. Trimble (1985:20) exemplified these rhetoric functions through technical manuals, as he explained:

“We find commonly the rhetorical functions of description, definition, and classification, and the rhetorical techniques of time order, space order and causality. In addition, manuals have two rhetorical features found less commonly in scientific and technical writing: the interpretation of illustration and the rhetoric of instruction”. (Trimble, 1985:20)

Knowing that, it is clear that, rhetoric is a very important element to consider in the analysis of written EST discourse. Following him, “rhetoric is the process a writer uses to produce a desired piece of text. This process is basically one of choosing and organizing information for specific set of purposes and a specific set of readers” (Trimble 1985::10). Additionally, Trimble (1985:10) explains the term ‘rhetoric’ as “one important part of the broad communicative mode called discourse”. However, “it is not a substitute for the term discourse, rather it is one part of the concept of discourse” (p4).

In order to have a much better understanding of rhetoric in EST discourse, Trimble (1985) explained it in a form of chart well known as ‘EST Rhetorical Process Chart’, which is shown in figure 2.

EST RHETORICAL PROCESS CHART	
Level	description of level
A. The objectives of the total discourse	
EXAMPLES:	<ol style="list-style-type: none"> 1. Detailing an experiment 2. Making a recommendation 3. Presenting new hypotheses or theory 4. Presenting other types of EST information
B. The general rhetorical functions that develop the objectives of Level A	
EXAMPLES:	<ol style="list-style-type: none"> 1. Stating purpose 2. Reporting past research 3. Stating the problem 4. Presenting information on apparatus used in an experiment <ol style="list-style-type: none"> a) Description b) Operation 5. Presenting information on experimental procedures
C. The specific rhetorical functions that develop the general rhetorical functions of Level B	
EXAMPLES:	<ol style="list-style-type: none"> 1. Description: physical, function, and process 2. Definition 3. Classification 4. Instructions 5. Visual-verbal relationships
D. The rhetorical techniques that provide relationships within and between the rhetorical units of Level C	
EXAMPLES:	<ol style="list-style-type: none"> I. Orders <ol style="list-style-type: none"> 1. Time order 2. Space order 3. Causality and result II. Patterns <ol style="list-style-type: none"> 1. Causality and result 2. Order of importance 3. Comparison and contrast 4. Analogy 5. Exemplification 6. Illustration

(Trimble 1985, p11)

Figure 2. Trimble's EST Rhetorical Process Chart

As we can see, the chart presents four levels as (Level A), (Level B), (Level C), and (Level D). The chart is based on the fact that a choice in one level determines choices at the next one. Thus, (Level A) refers to the objectives of the total discourse; however, (Level B) reflects the choices made at (Level A). On the other hand, (Level C) expresses specific rhetorical functions that are used to develop the general rhetorical functions selected at (Level B). The next level (Level D) represents the rhetorical techniques used to maintain relationships with rhetorical functions in (Level C). To give

more clarity to hierarchical organisation of the chart, Trimble (1985:12) explains rhetorical functions as referring to “what a given unit of discourse is trying to do”, while rhetorical techniques as “the frame into which the writers fit their information”.

With that being said, scientific English is generally described as an instrument to fulfil universal communicative functions in technical and scientific discourse. The notion of universality of scientific discourse is strongly supported by Widdowson (1978) who explained that most languages use universal concepts, method, procedures within scientific and technical discourse. According to him, scientific English is not simply some linguistic information about scientific terminology. In other words, scientific English is treated in a way that gives the impression that:

“It can be characterized in formal terms as revealing a high frequency of linguistic forms like the passive and the universal tense in association with a specialist vocabulary. But to characterize it in this way is to treat scientific discourse merely as exemplification of the language system and does little or nothing to indicate what kind of communication it is” (Allen and Widdowson 1978:59).

In addition, Widdowson (1978:59) sees scientific discourse as “a way of using English to realize universal notions with scientific enquiry”. These universal notions or concepts are not related to the native language of the scientist but they represent cognitive structures expressed in different languages. He believes that such cognitive structures of scientific enquiry are to be considered as, what he calls, ‘secondary cultural system’, which is different from the ‘primary cultural system’ that represents the scientist’s native cultural background. Furthermore, Widdowson suggested the notion of ‘common culture’, which mainly refers to ‘secondary cultural system’ that includes concepts and procedures of scientific inquiry. Thus, regardless of the differences scientists may have, as belonging to different ‘primary culture’, they have ‘common culture’ as they share certain discourse conventions. Widdowson explains clearly these notions of primary and

secondary culture by giving an example of Japanese and a Frenchman as having different beliefs, preconception and life style according to their primary cultural system. However, they have common culture expressed through the discourse conventions they share as scientists. These conventions, Widdowson (1979:51) asserts, are “independent of the particular linguistic means which are used to realise them”.

Another aspect of Widdowson view on scientific discourse is that “scientific discourse is a universal mode of communicating or universal rhetoric which is released by scientific text, in different languages by the process of textualisation”. In this regard, ‘textualisation’ refers to verbal and non-verbal mode of communication. While verbal mode indicates the linguistic features of a text, non-verbal is not expressed through language but rather with non-linguistic elements as drawing, graphs, tables, formulae and so on. In addition, these non-verbal elements are, in fact, a part of the deep structure of scientific discourse in the sense that they are universal and independent of any single language. That is, when analysing the communicative functions of discourse, including verbal and non-verbal features, it is clear that the analysis is no more restricted to the linguistic properties of a particular language (Gotti 2008). For more clarity, Widdowson explains the notions of scientific discourse, text, and textualisation using the following diagram, presented in figure 3.

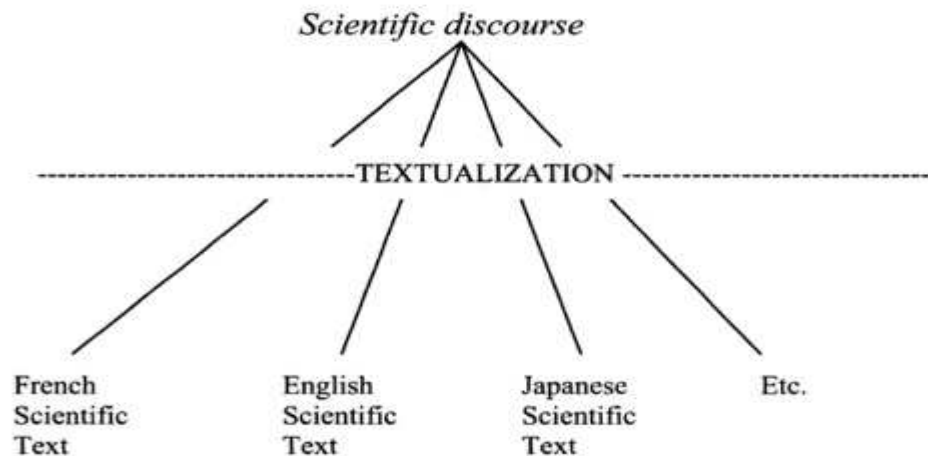

Figure 3. Widdowson's (1979:52) notion of discourse, text and textualization

When analysing a given piece of language taking into consideration only the linguistic features, it is likely that we are dealing with a text. Thus, a text in the scientific field, whether in English, French or even Japanese, is a physical representation of the language system. Analysing the text from this perspective can reveal different verbal features as vocabulary and sentence types. However, it does not reveal anything about the communicative functions of the text i.e. whether it is a report, an instruction or an account of an experiment (Widdowson 1979). In fact, such communicative functions do not represent the text as a linguistic entity but rather as a discourse. Furthermore, scientific texts include more than verbal features; they also include non-verbal ones as drawing, graphs and formula. As a result, taking into consideration the verbal and non-verbal features is what defines the process of textualisation. To put it differently, a scientific discourse is described to be so when only there is the consideration of communicative functions along with the verbal and non-verbal features (i.e. textualisation) in its description. If not so, it is more likely to be considered as an exemplification of the language system that can be described as a text (Widdowson 1979).

Conclusion

Using language to communicate depends on the communicative tasks we want to establish. Thus, the conveyed meaning must reflect clearly the purpose of such tasks in order to make a successful communication. To do so, interpreting the intended meaning does not only depend on the meaning of the actual words or sentence, but it has to take into account extra factors as context including setting and participants. Interpreting a discourse is going beyond the sentence level and tries to know its communicative purpose. However, when dealing with specific discourse, the interpretation of meaning involves more than context; it requires knowing the conventions used to structure such types of discourses.

Chapter two: Genre analysis and genre approaches

Introduction

Genre analysis is one of the area that stimuli linguists. Since the 1980s and 1990s, many studies have been conducted to answer different questions raised in the field of genre analysis such as ‘why do writers use the language the way they do? How can we differentiate between different types of discourses? This chapter provides an overview of genre analysis. It considers how the term genre is defined in linguistics in its broad and specific sense. More particularly, it presents a description of the workable definition established by Swales (1990) and deals with the different views known in the field of genre. It states the main approaches used in the analysis of genre from different perspectives.

2.1.Genre analysis

The term genre is a French word that means ‘type’ or ‘kind’ and has a wide range of meanings depending on the field in which it is used. In linguistics, the term is used mainly to refer to the classification of a group of discourses as belonging to the same type or class. In a broader sense, genre is defined as any instance of language use including newspapers, articles, interviews, and so on. These instances of language use are known in the world of genre as communicative events which have communicative purposes and they are recognized by the members of the discourse community in which they occur.

More particularly, as argued by Swales (1990:58), “genre comprises a class of communicative events, the members of which share some set of communicative purposes. These purposes are recognized by the expert members of the parent discourse community, and thereby constitute the rationale for the genre.” In the light of Swales (1990) definition, we are going to explain the main keywords used in the above

definition including: communicative event, communicative purpose and discourse community.

To start with, communicative event, as mentioned before, refers to any instance of language use; since the term 'language use' is involved, it implies that communicative events refer only to those activities that involve language. In other words, activities that have little use of language or no use at all are not to be regarded as communicative events. For instance consider the case of a football game where there is little use of language the reason why it is not regarded as a 'communicative event' (Swales 1990:45). In addition to that, communicative events are not of the same occurrence because some of them occur regularly or more frequently than the others. To make it clear, consider the case of a newspaper and a presidential conference. The former has more occurrence than the latter, which may occur only once a year.

Second, a communicative purpose is a very important feature that makes a communicative event occurs as a genre. That is, communicative purpose is one of the critical features that help categorizing genre. In spite of that, it is not always easy as one might think to identify the communicative purpose of a given genre. The reason behind this lies in the fact that there are some kinds of genres that have more than one communicative purpose. Thus, while it is true that the main communicative purpose of a recipe is to instruct people how they prepare a given dish, it is not the case for news broadcasting which includes different set of communicative purposes as keeping the audience up to date and moulding the public opinion.

Third, community members refer to the members of the community in which the genre at hand occurs regularly. These members share some conventions including style and content which help them to identify a given communicative event as a genre. This

means that non members of the community cannot recognize it as a genre since they do not share the same conventions. In other words, they are outsiders of the community in which genre regularly occurs. In short, these are the main characteristics of genre that were mentioned by Swales (1990) in his “workable definition” of genre.

Sharing the same concept of genre, many scholars based their works of genre analysis on that of Swales (1990). Bhatia (1993), Martin (1997), just to mention some, have to some extent similar views with Swales (1990) about genre classifications. Whatever the differences in their views, their common point is that of communicative purpose i.e. classifying genre according to its communicative purpose. Of course, not all of the researchers in the field of genre analysis agree on this notion of classifying genre. Thus, there are three main approaches in order to determine genre membership. These are: the functional approach includes such figures as Swales (1990), Bhatia (1993) and Martin (1997), the situational approach refers to Halliday’s (1978) work on systemic functional linguistics, and the new Rhetoric approach which is based on the work of Miller (1984).

2.2. Main approaches to genre analysis

In what follows we discuss the main approaches known in the field of genre analysis including, new rhetoric approach, functional approach, and situational approach.

2.2.1. New rhetoric approach

The new rhetoric approach is dated back to the work of Miller (1984). According to him, genre refers to “a conventional category of discourse based in large-scale typification of rhetorical action; as action, it acquires meaning from situation and from the social context in which the situation arose” (Miller 1984:163). Such view of genre

was adopted by many scholars like Bazerman (1988), Berkenkotter and Huckin (1995). Their studies were based on research articles in different fields as physics, biology, and general science.

Paltridge (1997) argues that new rhetoric approach gives more attention to “socio-contextual aspects of genres and the action of a particular genre aims to accomplish, as well as how these aspects might change through time than the formal characteristics of texts in isolation”. Following this view, it is more convenient to study genre from sociolinguistic perspective than from a linguistic perspective. Thus, as Flowerdrew (2002) and Hylland (2002) suggest, studies within new rhetoric are more likely to use ethnography rather than linguistic analysis. However, analysing linguistic features in new rhetoric are not completely ignored, but they are given a little attention because they are not the primary concern of the approach (Pho, 2013). In fact, such approach is more concerned with the relationship of text and rhetorical situation. In this perspective, genre is analysed according to the activities embedded in the text and how they are produced in social and cultural contexts. (Coe 2002:195).

2.2.2. The Functional Approach

To discuss the functional approach, we consider, first, Martin’s view of genre. According to him genre is “a staged, goal- oriented, purposeful activity in which speakers engage as members of our culture” (Martin 1985:25). In the light of this definition genre is identified by the purpose of the activity the speakers/writers seek to achieve. Thus, whatever the purpose of the activity, it is realized with the use of language passing through a set of “stages”. To put it differently, activities such as instructing, explaining, narrating are achieved following given steps or “stages”. The latter is, in fact, a kind of conventions shared by the members (i.e. writers) of the same

community in which the activity occurs. In addition, these conventions are a part of the members' culture. Therefore, the conventions shared by the members must be appropriate to their cultures. Besides, the "stages" are structured in a way that goes with the members "schemas" which represent their shared knowledge.

Following Martin (1985:25) "schematic structures represent the positive contribution genre makes to a text: a way of getting from A to B in the way a given culture accomplishes whatever the genre in question is functioning to do in that culture". This means that schema enables members to move from beginning to an end in an organized way, taking into consideration the necessary conventions that lead to the accomplishment of the defined task.

Since we are using the term "schema", it is worth mentioning what it means. With reference to the theory of schema, there are many types of schemas including formal, linguistic and content schemas. Formal and linguistic schemas are also known as "textual schemas" in the sense that they refer to rhetorical structures and forms of the written discourse. In other words, they represent the knowledge that we have about various types of discourses or genre. As members of a given discourse or genre, we acquire knowledge that makes us understand a given discourse; hence we are familiar with its structure and rhetorical organizations. To put it differently, "discourse with familiar rhetorical organization should be easier to read and comprehend than (texts) with unfamiliar rhetorical organization" (Carrell et al 1998:105). In addition, content schema is the background knowledge of the discourse. This means that it constitutes our knowledge about the topic, participants and cultural conventions that help interpreting the discourse at hand. To make it clear, schema is a "pre-existing" knowledge about "familiar pattern from previous experience that we use to interpret new experience" (Yule 1992:85).

However, schemas may occur at constant patterns i.e. they are fixed for certain events or experience. This consideration is known as frame. For instance consider the case of ‘apartment’; we have a pre-existing knowledge on the basis of which we assume that it contains such things as kitchen, bathroom, living room, and so on. Schemas may refer to a dynamic experience that includes a series of events. In this case, the schema is known as a ‘script’. “A script is a pre-existing knowledge structure involving event sequences. We use scripts to build interpretations of account of what happened” (Yule 1996:86). Thus, relying on our script we can know the different sequences in such events as going to a restaurant, or going to a doctor. Then, we can say that schemas are very important elements to consider when dealing with genre because they represent the pre-existing knowledge of sequences or “stages”, using Martin’s term, that are shared by the members of the same culture. In a similar way, frames are the “pre-existing knowledge” of the form or structure of the genre.

In addition to Martin (1985) view of genre, Bhatia (1993) argues that communicative purpose is the primary determinant for genre membership in the sense that job application and advertisement are classified within the same category of genre since they have the same communicative purpose of “promoting”. In fact, Bhatia’s (1993) work on genre is mainly based on that of Swales (1990).

Genre is characterized by the communicative purpose(s) that it is intended to fulfil. This shared set of communicative purpose(s) shapes the genre and gives it an internal structure. Any major change in the communicative purpose(s) is likely to give us a different genre; however, minor changes or modifications help us to distinguish sub-genre. (Bhatia, 1993:13)

From this quotation, we can notice that Bhatia (1993) sees communicative purpose as the primary criterion for classifying genre and that he pays a scant attention to such element as content, style, form and the intended audience. Although he did not deny the influence of these factors on the nature of genre, he believes that the change in the nature of genre is due to the change that occurs in the communicative purpose. Thus, he introduced the notion of sub-genre to refer to little changes on the part of genre.

Furthermore, Bhatia (1993:15) defines genre as:

An instance of a successful achievement of a specific communicative purpose using conventionalized knowledge of linguistic and discoursal resources. Each genre [...] structures the narrow world of experience or reality in a particular way, the implication is that the same experience or reality will require a different way of structuring if one were to operate in a different genre. (Bhatia, 1993:15)

On the basis of this definition, each genre is structured in a way that is recognized by the members of the community in which genre occurs. That is, genre conventions are shared knowledge that makes community members successfully achieve the intended communicative purpose. Besides, genre conventions are likely to change according to the genre in question and according to genre community members.

To sum up, the previously mentioned views of genre classify genre according to functional criterion namely communicative purpose. Although, Martin (1985) view of genre is slightly different from Swales (1990) and Bhatia (1993) it has a common ground with their views in terms of communicative purpose. The reason behind the difference between these views is that Martin (1985) view of genre is based on Halliday theory (1978) of systemic functional linguistics which we are going to consider when we deal with the situational approach.

2.2.3. Situational Approach

After considering the functional approach which spins around the notion of communicative purpose, we move to the next approach which is situational features. This approach is mainly based on Halliday (1978) work on systemic functional linguistics (SFL). Thus, it is worth knowing what is meant by systemic functional linguistics.

To start with, systemic functional linguistics owes its emergence to Firth (1951) who put the framework of the theory. Following Firth (1951), linguistic patterns are interpreted according to meaning context and lexical items are interpreted in the lexical context. On the ground of this notion, one of Firth's students, namely Halliday (1978), developed a theory that entails the analysis of meaning taking into consideration the paradigmatic dimension. That is, meaning is explored through the structural organization of language. According to Halliday (1978:35), language is a "social semiotics" that people use to fulfil everyday social life. That is, the function of language is to make meanings, which depend on the cultural and social contexts. Approaching language from these aspects is the main concern of systemic functional linguistics.

To answer such questions as how is language organized to make meaning? Halliday focused on meaning generated by language. Following him, language is organized according to three types of meanings. These are the ideational, interpersonal and textual meaning. They refer to language experience, people relationships and how language hangs together respectively. The following example will clarify the point.

'I suggest we see the polar ones'.

Deprived from the context, it is difficult to interpret the meaning of this utterance. More particularly, we do not know what this utterance is about. In other words, we do not

know the ideational meaning of the utterance. In addition, there is some ambiguity about the relationship of the participants (the speaker and the listener). The reason behind this is that the use of the word 'we' which may imply a friendly relationship or an authoritative one. However, giving context to the utterance will reveal the ambiguity of the ideational and interpersonal meanings. Thus, the utterance for instance would be: 'let's see the bear'. 'I suggest the polar ones'. Such kind of information makes it possible to understand the 'meanings' of the utterance. That is, the ideational meaning is 'the bears' and the interpersonal one is that the relationship between the participants is a friendly one since the interaction is taking place in a zoo. In addition, this piece of language is coherent since there is the use of cohesive devices namely substitution i.e. the use of 'ones'.

From the above example, one can notice that the three types of meanings are understood from the context of the utterance. This implies that the context that helps in the identification of 'meanings' is provided by the text (or the piece of language at hand) itself. In another way, there is a considerable relation between language and context. Eggins (2004:48) describes this relationship as "our ability to deduce context from text is one way in which language and context are interrelated. Our equally highly developed ability to predict language from context provides further evidence of the language context relationship". Consequently, it is possible to predict the context providing language as it is possible to predict language providing context. The following example will illustrate the point.

Peel the onion and push cloves into it. Simmer gently with milk and butter for at least twenty minutes. Remove the onion. Pour the milk over the bread crumbs let this stand to thicken ad reheat before serving.(Yule 2006:135)

Clear enough that this piece of language represents a recipe. The language used in this example is that of recipe hence it includes such items as onion, milk, and breadcrumbs. These items constitute the ‘ingredients’ of the recipe. In fact, even if we find these items in isolation as in magazine, or a newspaper, we are likely to interpret them as the ingredients of a recipe. Thus, context, as Eggins (2004:7) clarifies, “is in text; text carries with it as a part of it, aspects of the context in which it was produced and presumably within which it would be considered as appropriate”.

So far, we mentioned the context of situation and the context of culture. However, a distinction must be drawn between the two since context of situation is related to register and context of culture to genre. Thus, the differentiation between register and genre is one of the controversial issues that face linguists.

According to Eggins (2004:32) “genre and register are at two different levels of abstraction. Genre or context of culture can be seen as more abstract, more general; we can recognize a particular genre even if we do not know exactly what the situational context is”. This means that genre and register are separate terms each of which has its own context. In addition, register is “relevant to a particular situation of use of a genre” (Eggins, 2004:111).

Register is “a variety associated with a particular situation of use including particular communicative purpose” (Biber 2006:11). The analysis of register entails three components: the situational context, the linguistic features and the functional relationship between them. The linguistic features that occur within a given register go with the situational context of the register at hand. Since register analysis focuses on the ‘pervasive’ linguistic features in the text, we can either analyse the whole text or just take a sample of it. However, this is not the case for genre because in genre analysis

linguistic features are conventional rather than functional. That is, they occur only once in the text; the reason why we must take the whole text into consideration. For example, we consider the case of face to face conversation. In such a situation the participants share time and place; they may discuss several topics related to their beliefs, hobbies, or political decline. Of course, in order to make the conversation possible both participants must speak. Situational features of face to face conversation help the distinction of other types of conversations. For instance, telephone conversation is different from face to face in that participants do not share the feature of place. Moreover, linguistic features of a conversation are identified by the use of the 'pervasive' ones. Generally, the most common features in conversation are the use of first and second person pronouns in addition to the use of questions.

Unlike register, genre analysis gives more attention to the linguistic characteristics that structure the whole text; hence the linguistic features in genre are "conventionally associated with the genre they conform to the culturally expected way of constructing texts belonging to the variety" (Biber and Conrad 2009:15). To make the image clear, let us consider the case of letter writing as a model of genre analysis. In order to analyse a given letter, one must take into consideration the whole letter from beginning to end. Unless we do that, we cannot know for instance that the letter starts with the date at the top followed by the name and address of the recipient and closed by polite expression such as 'yours sincerely'. Therefore, the conventions that organize and shape the genre are of much importance in recognizing a given text to belong to a given genre. With a view to clarify the difference between genre and register the following table presents the main defining characteristics of both genre and register.

Defining characteristics	Register	Genre
<i>Textual focus</i>	Sample of text or excerpts	Complete text
<i>Linguistic characteristics</i>	Any lexico-grammatical features	Specialized expressions Rhetorical organization Formatting
<i>Distribution of linguistic characteristics</i>	Frequent and pervasive in the texts from the variety	Usually once occurring in the text, in particular place in the text
<i>Interpretation</i>	Features serve important communicative functions in the register	Features are conventionally associated with the genre. The expected format but often not functional

Table 2. The main defining characteristics of genre and register

To sum up, register and genre are two different perspective of text analysis. That is, each perspective focuses on specific area of study. Genre analysis sheds light on linguistic features that are conventionally used in the text. Thus, the analysis requires the whole text for the study. However, register gives more attention to more frequent linguistic features that are associated with a given situation which makes it possible to identify these features either through the whole text or trough a sample of the text. Although, register and genre analysis have different perspectives of study, they both analyse the way in which linguistic features are used in the text varieties taken into consideration the situational features. This consideration makes it possible to apply the same framework of analysis for both register and genre in terms of situational features. The following figure shows the situational characteristics that are common for register and genre.

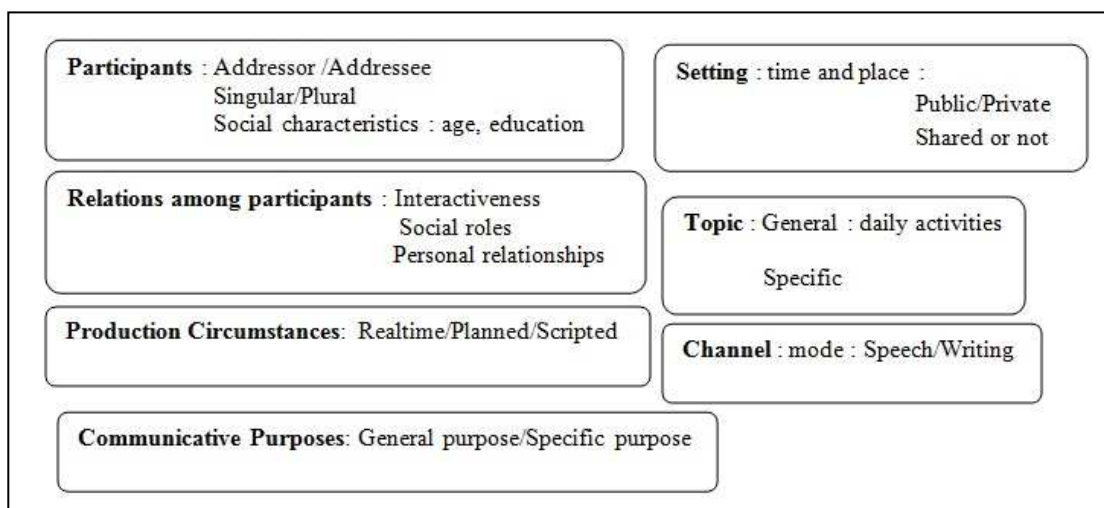

Figure 4. Situational characteristics of register and genre (Biber and Conrad 2009:40)

This figure provides a general view of the situational characteristics of genre and register including participants, relations among participants, channel, production circumstances, settings, communicative purposes and topic. These characteristics are explained thoroughly in the ongoing discussion.

2.2.3.1.Participants:

The participants refer to the individuals involved in the conversation or text. They are of two types: the addressor and the addressee. The first one represents the one who produces the text. In the written form, the addressor varies from a single individual to an institution or organization. Thus, in such a case, the addressor is apparent; we do not know who produces the text. For instance, the user manual –in our study- is produced by a given company but without any indication of the author. The second type refers to the one who receives the text. Like the addressor, the addressee can be attributed to a single individual as well as to multiple individuals. For instance, in peer-to- peer writing there is one individual writing to another one. The same thing can be said about face to face conversation. Besides, the addressee might represent a large group of people which is the case of magazines, journals, books where one author address a large audience.

2.2.3.2.The relationship among participants:

Once the participants are identified, one needs to know the relationships between them. In the analysis of the relationship among participants, many things are to be considered including interactiveness, social roles, and personal relationships. Interactiveness refers to whether the participants interact with each other or not. This differs, mainly, on the situation. In a conversation, the participants can interact directly with each other. However, it is not possible in case of magazine, journal, for instance, because the participants are distant from each other. Moreover, participants may have the same social status as classmates for instance. The type of the interaction between classmates is different from the interaction that one may experience with his parents or his teacher. The social relationships that one has with others depend on the social status. Thus, the latter is very important feature that can influence the choice of words and behaviour that one may use in the interaction.

2.2.3.3.Channel:

Channel refers to the way in which one conveys a given message and it is related to two modes of interaction either spoken or written. Generally, in the spoken form the participants are easily identified since in most of the cases the participants interact directly. However, in the written form participants are not easily determined because they do not have a direct interaction. In addition, participants in the written mode may refer to institutions rather than a single individual. Even though written and spoken language represents the main modes of interaction, there are new ways of interactions, within the spoken and written modes, that emerge from the technological advances such as radio, telephone, electronic texts (email), video conference and so on.

2.2.3.4.Production circumstances:

The circumstances in which the text/register is produced have something to do with modes of communication (channel) whether spoken or written. For instance, in the case of the spoken form, the speaker does not have much time to think about what he will say next. Thus, he must think and speak at the same time; otherwise he may interrupt the conversation with pauses in order to think. Furthermore, in such circumstances the speaker cannot revise or delete what he already said. Unlike the spoken mode, participants in the written mode have the ability to edit revise and even delete an inappropriate piece of language. This feature gives them much more time to think and choose the appropriate words that convey the intended meaning. On the one hand, the listener has no choice but to understand what the speaker wants to say at the time of speaking because he does not have the possibility to control the speed of the speech. This makes him very attentive to the speaker's speech since he cannot understand fully the conveyed message if he misses some parts of the conversation. The written mode, provides much ease for the reader hence he has got enough time to read carefully or to skim through paragraphs and even to go back to a particular point in the text.

In short, the speaker and listener ability to control any piece of language depends on the circumstances of its production. Thus, in the spoken mode both the speaker and the listener have a little to control whereas in the written mode they have a complete control of the piece of language in question.

2.2.3.5.Setting:

The setting of the interaction refers to both time and place. More particularly, the setting is represented by the physical context the text/conversation. Sharing the same physical

context (time and place) is very common in spoken language. This feature makes it easy to use reference markers such deictic expressions as ‘here, there, tomorrow, yesterday,’ and so on. In addition, there is no room for ambiguity or misunderstanding on the part of the participants in comparison to the written mode. In this concern, the addressee is more likely to be confused or misled by the addressor if he uses such expression as ‘here, yesterday, tomorrow’ and so forth. The reason behind this is that the participants do not share the same physical context i.e. time and place. For instance, what might be mentioned in the text as ‘yesterday’ might took place in the previous week. As a result, the writer must make sure that the reader can easily understand such referring expressions.

2.2.3.6. Communicative purpose:

It is very important to know the purpose of the interaction at hand because the language we use depends on the purpose that we want to achieve. Knowing this, it is worth mentioning that communicative purposes differ from general to specific. General purposes can be identified easily in such register/text as narrating, describing, and instructing. However, specific purposes of the register/text are not explicitly expressed. Therefore, many registers/texts have a multiple set of communicative purposes which makes it sometimes very difficult to determine the specific communicative purpose of the register/text. For instance, engineering textbooks show more than one communicative purpose hence they include explanatory and instructing purposes. In addition, a general purpose can be expressed through a set of specific purposes. Research articles, for instance, are expressed through introduction, method, results and discussion sections. These sections have a specific communicative purpose. In other

words, they seek to provide the background knowledge of the research, describe the methods and tools used, and discuss the results and findings respectively.

2.2.3.7.Topic

The topic of the interaction has a great influence on the choice of words in the sense that the vocabulary used in the register/text depends mainly on the topic or domain of the interaction. Therefore, if the topic in question is about science, we can expect words that are related to the field of science. Thus, we cannot expect to find words belonging to the field of politics in science, for example. Furthermore, the topic of the interaction tends to be of two types: general or specific. To put it differently, we say the topic is about science, sport, or politics which are, in fact, general topics that can be more specific. For instance, we consider a topic in the field of science where one might find specific topics about biology, which in turn might also include more specific topics as microbiology.

2.2.3.8.Register features and Markers versus Genre markers

Register features are, mainly, lexico-grammatical features used more frequently in the register. For instance, the passive voice is one of the register features that can be found in academic writings. Register markers, on the other hand, are distributive characteristics i.e. they facilitate the distinction between two different registers. The following example will make a relevant image.

- The count is three and two

This expression represents a register marker in the sense that it occurs only in baseball games. Thus, if we are familiar with baseball games, we can easily identify the register as belonging to sport and namely to a baseball game. What makes register markers

different from register features is that register markers, as seen in the example, are restricted to the register at hand. That is, we cannot, for instance, find such expression as ‘the count is three and two’ in a basketball game. Furthermore, register markers are so frequent or ‘pervasive’ in registers hence they are used in the distinction of different registers.

While it is true that register markers are ‘pervasive’, genre markers are limited because they occur only once. For instance, in the genre of research articles, the introduction section occurs only once. Genre markers are similar to register markers in the sense that they help differentiating between various genres. For instance, the expressions used in legal trial and sermon help to make the distinction between the two genres because it is evident that one cannot expect to find ‘Amen’ in lawsuit but rather in a sermon. To make it clear, consider the following;

- We find the defendant guilty /innocent
- Amen’

These expressions are genre markers for legal trial and sermon respectively. In addition to the fact that they make us discriminate between both types of genres, these markers occur only once, namely at the end of the legal trial and sermon respectively. For more clarity, the main differences between register features and markers and genre markers are shown in the following table.

Type of linguistic characteristic	Analyzed in complete texts or text samples?	Distribution of the characteristic	Frequency of characteristic in a particular variety compared to other varieties	Use of the characteristic in other varieties	Characteristic functional or arbitrary / conventional?
register feature	text samples (or complete texts if short)	pervasive	more frequent	occurs in other varieties, but less commonly	functional
register marker	text samples (or complete texts if short)	pervasive	more frequent	does not occur in other varieties	formulaic and arbitrary / conventional (usually not functional)
genre marker	complete texts	often occurs only once, at a particular location in the text	often occurs only once, so not very common	usually does not occur in other varieties (may occur in closely related genres)	formulaic and arbitrary / conventional (usually not functional)

Table 3. Register features and markers, genre markers (from Biber et al 2009:55)

Although the genre markers are useful to distinguish between different genres, there are other steps to consider in the analysis of a given genre. These steps present a framework of analyzing genre. Following Bhatia (1993), there are a number of steps to follow while dealing with genre analysis. These steps are:

1. The setting of the text
2. The focus and perspective of the text
3. The intended audience for the text, their role and purpose in reading the text
4. The relationship between writers and readers of the text
5. Expectations, conventions, and requirements for the text
6. The background knowledge, values and understandings it is assumed the writers share with their readers, including what is important to the reader and what is not.
7. The relationship the text has with other texts

In fact, Bhatia (1993) proposed these seven steps as a model or a framework to analyse unfamiliar genres. The first step ‘the setting of the text’ refers to placing the genre in situational context. The second step, which is ‘the focus and perspective of the text’, is achieved through the ‘survey of existing literature’ particularly to those who do not

belong to the discourse community of the genre. The third and fourth steps are used to identify the participants. That is to answer two questions: who are the audience and writers of the text? And what is their relationship to each other? The fifth step is based on the selection of the genre and more particularly the texts that are to be analysed. This step entails knowing well the genre in question i.e. knowing the conventions and expectations of the texts. In addition, it is related to the sixth step that includes knowing the cultural and social context of the genre. Thus, writers expect readers to share conventional and cultural values used in the texts as a background knowledge that helps them recognizing the genre at hand. However, this step is mainly achieved through other sub-steps including analysis of lexico-grammatical features, analysis of text patterning or textualization, and analysis of the structural interpretations of the text. In other words, the first sub-step refers to the analysis of the frequency of syntactic properties. The second sub-step is concerned with how linguistic features are used in different genres to achieve different things. The third sub-step is about the cognitive aspect of organizing genre in order to reveal the constant way that writers follow in order to structure the genre. Once the three sub steps are used, it is possible to determine the difference between the texts in terms of whether they belong to the same genre or not. Besides, it is possible to define the relationship of the texts to each other and even to other texts within different genre. This consideration is the main concern of the seventh step in the framework. Relying on the sixth step, one can also determine which text belongs to which genre. In order to be sure of the obtained results, Bhatia (1993) suggested consulting a 'specialist informant'. In other words, discuss the results with a specialist in the genre who is an expert member of the discourse community. This assumption is very useful to validate or gain additional information about the nature of genre.

However, applying these steps in the analysis of genre does not mean that one has to follow them exactly in the order mentioned above. There is an alternative that one can use one step and switch to the other depending on what he wants to investigate or analyze in the genre at hand. To put it differently, “the steps must be used flexibly and selectively” (Paltridge 2006:68). It is also worth mentioning that Bhatia’s (1993) framework, represented by the seven steps, is mainly based on the notion of the communicative purpose. As he clarifies “genre is primarily characterized by the communicative purposes that is intended to fulfil. This shared set of communicative purposes shapes the genre and gives it internal structure” (Bhatia 1993:13). To make it clear, the internal structure of the genre, for him, is achieved by three interrelated elements including communicative purpose, moves and rhetorical strategies. In other words, communicative purpose is the primary criterion for genre identification. The latter shapes the genre into the so-called moves. In return, moves are realized through a set of rhetorical strategies.

In the aforementioned views of genre, we have seen the influence of communicative purpose on genre identification. However, there is a scant attention on form, style, content, and intended audience. Thus, neglecting such factors will be misleading while classifying a given genre. In addition to that, it is very important to consider the community in which genre regularly occurs. The latter has a great influence on genre membership hence each community has its own style, content, form and the intended audience. Therefore, in what follows we will consider the influence of discourse, or genre, community on the classification of genre.

2.3.Discourse Community

Discourse community refers to a group of people with shared activities, goals and beliefs. Thus, these activities make them belong to the same discourse community. In addition to the things they share, as members of discourse community, they interact or communicate with each other in a way that is agreed upon by all the members. For instance, students who go to the same university have the same discourse community. The way they communicate with each other is based on academic conventions that they share with all the members of the same community. Furthermore, a member of a given discourse community is not only enclosed within only one community. That is, members may belong to more than one discourse community at the same time. If we consider the example of the students, we find that students may belong to the same discourse community at university but, at the same time, they may be members of political discourse community if they are militants in different political parties. There are also other cases where there is a small discourse community within a large discourse community. To make it clear, let us consider the example of the students belonging to different departments in the same university. Thus, the departments themselves are discourse communities included in a large discourse community that is the university community.

The notion of ‘discourse community within discourse community’ is best illustrated in Swales work (1998) “other floors, other voices”. While he worked in one of the university floors, he noticed that people doing different activities occupied the other floors. Seeking to know what sort of activities they were engaged in, he interviewed the staff members of these floors. As a result, he realized that these members, in fact, were producing different kind of texts depending on the floor in

which they were working. Therefore, each floor in fact was a kind of discourse community on their own within the same discourse community the university. Swales suggested the term “place discourse community” instead of discourse community to refer to such a phenomenon (Paltridge, 2006).

In spite of the fact that discourse community members share the same activities they tend to be of three types as suggested by Devitt (2004). These are: communities, collectives and networks. Communities refer to people who share time and place since they work together in the same office for instance. Collectives refer to those groups of people who have less frequent contact in the community as results of activities they perform for instance telephone advice service. Networks are group of people who have never met each other so they do not share time and place. The social networks on the net best illustrate this kind of communities.

Whatever the discourse community might be, each of which has the same characteristics that distinguish it as a discourse community. For Swales (1988), a distinction must be drawn between the two concepts namely ‘speech community’ and ‘discourse community’. Following him, in the former “the discourse creates the community” and in the latter “the community creates the discourse”. He clarifies saying that “speech communities are centripetal i.e. they pull people in while discourse communities are centrifugal i.e. they set people, or parts of people apart” (p. 212). To put it differently, the membership in a discourse community is formed on the basis of familiarity of the discourse at hand. Thus, members of a given discourse community are so because of their relationship to the discourse they practice regardless of time and place. For instance, consider the case of social networks although they do not meet each other, which means they do not share the same time and place, they are said to belong to the same discourse community due to their relationship. On the other hand, speech

community members share the same language, geographical area, beliefs and values. This means that they create their own community relying on these shared features. In another way, in the case of discourse community, the discourse is the common core for the members while in the case of speech community the common core is the member themselves. The following diagram will illustrate the point:

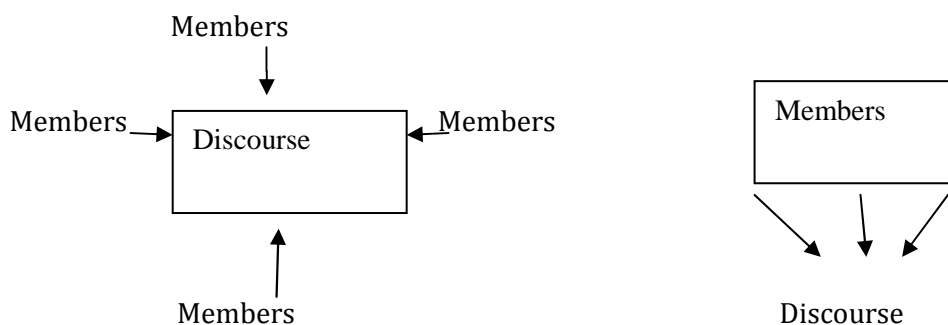

Figure 5. Members and discourse community relationship

Besides to the difference between ‘discourse community’ and speech community, it is worth mentioning that not all groups of people are to be regarded as a discourse community unless they have a set of features that make them so. The following characteristics of the discourse community are proposed by Swales (1988:212):

- a. The discourse community has a commonality of interests i.e. they share the same purposes and goals.
- b. The discourse community has mechanisms for intercommunication i.e. they have certain ways to communicate between each other such as meetings and so on.
- c. The discourse community survives by providing information and feedback.
- d. The discourse community has developed and continues to develop discorsal expectations i.e. discorsal elements including form, function, topics that represent the conventions that make genre.

- e. The discourse community has its own terminology i.e. it makes use of specialized vocabulary using abbreviations and acronyms.
- f. Discourse community members have a relevant discourse and content expertise. However, an equivalent must be placed between experts and those who recently enter the discourse community i.e. novice.

Although these characteristics are useful to identify the discourse community, they are not free from problems. Swales himself admits that “characterizing discourse communities in this kind of ways leads to a number of consequences.” (Swales 1988:213). To view it differently, sharing things in common does not mean that we belong to the same discourse community. In addition, discourse community may survive even if the relationship between members is low. That is, knowing personal information about the members is not a criterion for maintaining the discourse community. Thus, people may descent from different cultures, but still they work or belong to the same community. Whatever the differences between the members, they can share the same genre. The best example for this consideration is the case of a ‘network’. In a network the relationship between the members is not so strong hence they may not have a lot of information about each other but they belong to the same community.

According to Devitt (2004:39) “community are better defined by their common goals, values, or identities rather than their common discourse or genre.” In other words, discourse or genre reflects the commonality of goals values and identities among the community members. To support his view he suggests the case of lawyers and judges. Thus, the shared discourse of lawyers and judges is not the one that identifies the community but rather the things those lawyers and judges have in common which

determine the community. The reason behind this is that the concept of discourse community focuses more on the discourse rather on the social relationships that shapes the discourse. This means that “[discourse community] emphasizes too heavily the role of discourse in constructing groups and not enough the role of groups in constructing discourse.” (Devitt 2004:39).

From another perspective, however, using discourse community in this sense makes it difficult to distinguish between the two terms namely ‘speech community’ and ‘discourse community’. In addition, there are many cases where people work together regardless of their personal relationships. This consideration is illustrated by Swales (1988) when he described his own experience in hobby groups. He described those groups as ‘detached from personal involvements’. That is, he does not know whether the group members are rich or poor, single or married, and so on. Although he did not share belief values with the members, they form a discourse community on the basis of common goals, information exchange, genre development, specialized terminology and expertise.

2.4.Moves and rhetorical strategies

Moves are discriminative elements within genre structure. That is, if any significant change occurs at the level of the moves, it leads to the emergences of different genre or sub genre. On the other hand, rhetorical strategies do not influence the nature of genre since they represent the writers’ choices and intentions. Thus, strategies are motivated by non-linguistic features. In some cases, the term ‘step’ is used instead of ‘strategy’. In his well known model CARS (Create a Research Space), Swales (1992) showed that the main moves used by writers of research articles are realized through a number of steps

(strategies). To make the image crystal clear, Swales' model of research articles is outlined in full.

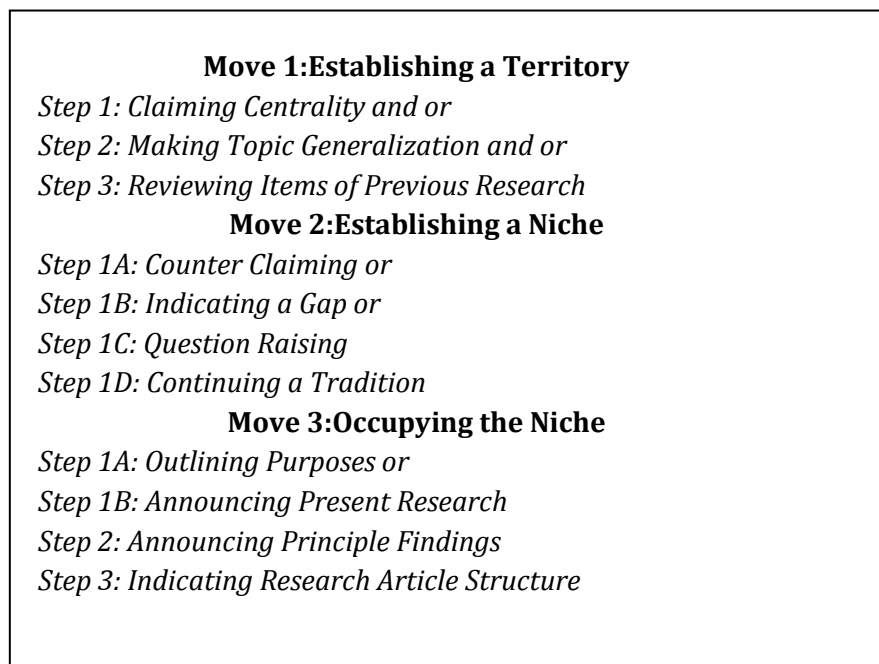

Figure 6. Swales' Moves in Research Articles Introductions

Each of the moves in Swales' model is achieved through a number of steps. The use of the steps is an indicator of the move. For instance, if one finds the use of such steps as "claiming centrality" or "reviewing items of previous research", it is likely that the move used is "establishing a territory". Thus, whether one or all the steps are used we still have the same move. As a result, steps do not affect the nature of genre as do moves. The change in the move itself may lead to a different genre.

In terms of Bhatia (1993), steps are strategies used to achieve the intended communicative purpose. The communicative purpose of the genre is used mainly to define the nature of the genre. In addition, communicative purposes vary from general to specific. According to Bhatia (1993:632), "the concept of communicative purpose is very versatile. On the one hand, it can be identified at a fairly high level of generalization, whereas on the other hand, it can be narrowed down to a very specific

level.” To give it more substance, let us consider Bhatia’s (1993) model of promotional genre.

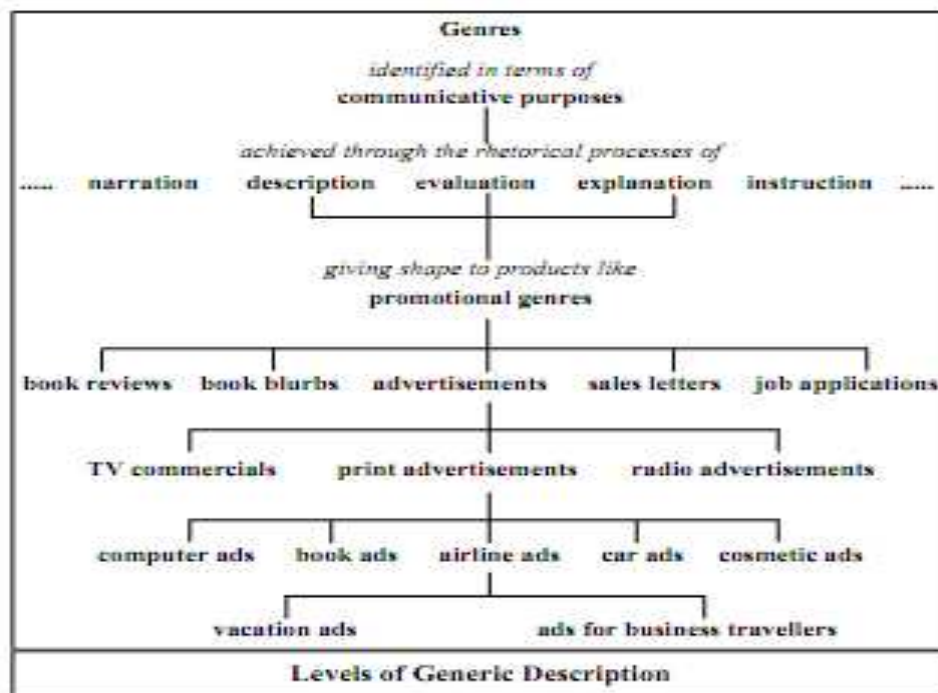

Figure 7. Bhatia’s model for promotional genre

Following this model, promotional discourse has a general communicative purpose of ‘promoting a product or a service to a potential customer’. Thus, advertisement, sales letters, job applications are classified in the same category in the sense that they ‘promote’ something, be it a service or a product. In addition, the communicative purpose of promoting can be considered at lower level of generalization. To make it clear, consider the instance of advertisement in the model where there are other sub categories including printed advertisement, TV commercials, and radio advertisement. In turn, printed advertisements can be classified to further sub categories as book advertisement, car advertisement, and cosmetic advertisement, etc... Even though the sub categories have specific purposes they all flow in the general communicative purpose of ‘promoting’. Therefore, regardless of the strategies used to achieve these purposes, the different categories are to be classified within the same genre. As Bhatia

(1997:634) clarifies, “whether one uses rhetorical situation or communicative purpose as a privileged criterion, it implies that so long as the communicative purpose remains the same, the texts in question are identified as closely related”. However, such model is not workable for all genres because it does not take into account the fact that texts may show a multiple set of communicative purposes. Thus, the question that raises here what communicative purpose shall we consider for the classification? This question makes us reconsider the notion of communicative purpose as the primary criterion for genre membership.

2.5.Communicative Purpose and Genre Membership

The notion of communicative purpose as “a privileged criterion” is a controversial issue. Swales himself admits that the term communicative purpose is ‘slippery’. He argues that “[...] it may be objected that the purpose is somewhat less overt and demonstrable feature than say, form and therefore serve less well as a primary criterion” (Swales 1990:46). In addition, communicative purpose is not always easily identified particularly in the case of multiple communicative purposes. For instance, news broadcasts have a communicative purpose of informing and keeping the public up to date. While this is true, Swales (1990:47) believes that the news also have another communicative purpose which is “moulding the public opinion, organizing public behaviour”. This consideration makes Askehave (1999) introduce the terms ‘official communicative purpose’ and ‘hidden communicative purpose’. In the example of the news, the official communicative purpose is keeping the public up to date and the hidden communicative purpose is moulding the public opinion. This implies that there are two types of communicative purpose: official and hidden. Following his notion of communicative purpose, he claims that the “distinction is quite important if we use the

term communicative purpose as genre determinant” (Askehave 1999:18). As a result, he disagrees with Bhatia’ (1997) notion of communicative purpose in the sense that Bhatia (1997) notion is too general. That is, the fact that job application and advertisement are classified within the same genre because, they both, have the same communicative purpose is inconvenient. He advocates, “the problem with this definition is that it is so general that it does not contribute much to the description of the genre as intentional and purposeful activity” (Askehave 1990:20). As a way of supporting his view, he analyses the company brochures as an example of promotional genre. With a view to understand why do companies write a company brochure, he conducted a thorough analysis of many company brochures taking into consideration the context of their occurrences. In other words, he considered the industrial markets as the context of company brochures. As he clarifies “in order to detect what the company is trying to achieve, through its promotion, we have to turn to the industrial markets, goals and intentions of the participants in the industrial market” (Askehave 1990:20). Thus, taking into account the industrial market as a context of the genre, the analysis revealed that company brochures have hidden purposes. That is, apart from the communicative purpose of ‘promoting’, company brochures serve also to present the company as a ‘qualified partner’. The latter is expressed through the use of specific words and sentence structure as shown by the analysis of lexico-grammatical features.

As a result, the analysis of company brochure confirms not only Askehave (1999) notion of communicative purpose but also that of Swales (1990) who considered the term as ‘slippery’. Moreover, Askehave (1999) analysis of company brochures determines that the hidden communicative purposes, expressed by a given genre, have something in common. That is, they cannot be assigned to a particular genre; hence they can be achieved through a variety of genres. Next, they are extremely subjective in the

sense that the purposes differ from one writer to another. Besides, they are indefinite i.e. there are many reasons of producing genres. Therefore, this assumption raises many difficulties in assigning genre membership. Moreover, communicative purpose is not the only criterion of classification there are other criteria that must be considered as well, including form, content, and audience.

Since communicative purposes might be subjective i.e. based on the writer intention, they cannot be used as the primary and the only criterion for genre membership. In Bhatia's (1993) terms, the notion of subjectivity of the communicative purposes is expressed by the 'private intentions'. Thus, according to him "genre is highly structured and conventionalized with constraints on allowable contributions in terms of their intent, positioning, form and functional value. These [...] are often exploited by the expert members of the discourse community to achieve private intentions within the framework of socially recognized purposes" (Bhatia 1993:13). To put it differently, the expert members use genre conventions not only to produce a recognized genre, but also to convey their 'private intentions' through these shared conventions. Bhatia (1993) prefers to call this phenomenon a 'tactical aspect'. To make the image clear, consider the case of news reporters who may imply their political incline through the objectivity and conventions of writing a report.

Although the notion of subjectivity or 'private intentions' gives the term communicative purpose more complexity, one must bear in mind that the use of 'private intentions' in the production of genre is not due to the members lack of knowledge but in fact from their expertise in the field. That is, as 'insiders' of the discourse community to which they belong they can use their knowledge of the field to convey 'private intentions' implicitly. On the other hand, the 'outsiders', who are not members of the discourse community are likely to have no or less knowledge of genre conventions. As a result,

they will find more difficulties in revealing the hidden communicative purposes or as Bhatia calls them ‘private intentions’.

The terms ‘insiders’ and ‘outsiders’ are used to differentiate between the members and non members of the discourse community. In order to understand the view of the ‘insiders and the ‘outsiders’, it is worth considering Widdowson’s (1998) use of the terms. Let us consider, for more clarification, the following example which is used originally by Widdowson (1998:63).

In homes, a haunted apparatus sleeps, that snores when you pick it up.

If the ghost cries, they carry it to their lips and sooth it to sleep with sounds.

And yet, they wake it up deliberately by tickling with a finger.

(A Martian Sends a Postcard Home)

The first question that might come to our minds, after reading this paragraph, is that ‘what is the text about?’ As readers, the text is cohesive but incoherent. That is the sentences are linked together; however, we cannot make sense of them. That is, we lack some knowledge of the text to make it more coherent for us. The key to this problem lies in the title of the text. Considering the title, we know that this text is in fact a description made by a Martian who is an ‘outsider’ of the planet Earth. This means that he is not familiar with Earthy things such as telephone. Knowing that, the text is no more ambiguous since we know that the object being described is a telephone. Therefore, the view of an ‘outsider’, the Martian for instance, is quite different from our view of the telephone as ‘insiders’. Sure enough, that, our description of the telephone, if we are to describe it, would be different from that of Martian since we are familiar with this device.

Applying this assumption to genre analysis, the ‘insiders’ in this case are the members of the discourse community who can recognize the genre on the basis that

they share the same communicative purposes and the same conventions. Unlike the members of the discourse community, non members or ‘outsiders’ cannot, or find it difficult to, recognize the genre at hand. The conventions are not only to recognize the genre but also texts that need to be classified. As Widdowson (1998:7) clarifies, “conventions imply community and membership is mediated with the meaning of the text. It is not just a matter of knowing the semantic meaning of the words.” Being able to understand or recognize the text genre implies that we can make sense of it not because we understand the language of the text but rather we are members of the discourse community and we are familiar with the genre conventions.

Besides, understanding the language of a given text involves the understanding of different “aspects of common culture which define a particular discourse community” (Widdowson 1998:9). Knowing that, language as a means of communication is also used to convey “shared schematic knowledge of ideational patterns of conceptualization and interpersonal pattern of conventions shared beliefs, values and conventions of behaviours” (Widdowson 1998:9).

Furthermore, Widdowson (1998) suggested other terms, namely ‘mastery’ and ‘mystery’, which refer to the ‘insiders’ and ‘outsiders’ respectively. This means that what is mastery for the expert members of a given discourse community is a mystery for non members. Our daily life provides good examples for the use of the two terms since one can find himself in either of the cases i.e. belongs to the mastery or mystery category. For instance, as patient we consult doctors for our health sake. The doctors in this case have mastery in their field. However, what is mastery for them is, in fact, mystery for us as patients. Thus, their mastery of the field makes them as ‘insiders’ of medicine discourse community. In turn, patients are ‘outsiders’ because they do not belong to doctors’ discourse community.

After considering the notion of communicative purpose and the difficulties it raises in assigning genre membership, it is worth suggesting solutions or convenient methods to cope with the complexity made by the use of communicative purpose as the primary criterion of classifying texts and hence identifying genres. Thus, in what follows, we present Swales and Askehave (2001) framework of genre analysis as a solution to deal with the notion of communicative purpose. They suggest that one must get rid of the notion that communicative purpose is a rapid way of identifying genre membership. As they point out “it would be prudent to abandon communicative purpose as an immediate or even quick method for sorting discourse into generic categories” (Swales and Askehave 2001:207). This consideration makes them generate new frameworks which are not based primarily on the communicative purpose. They rather believe that convenient models for genre analysis are based on whether the analyst makes use of the “text-first approach” or “context-first approach”. The former refers to the linguistic approach and the latter to ethnographic approach. The following diagrams will clarify the point.

The first model:

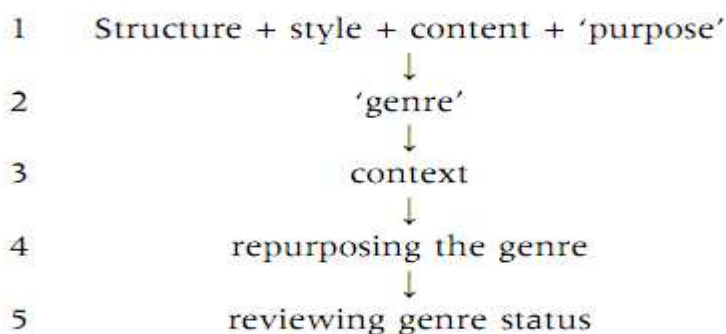

Figure 8. Text-first approach for genre analysis (Swales and Askehave 2001)

The second model:

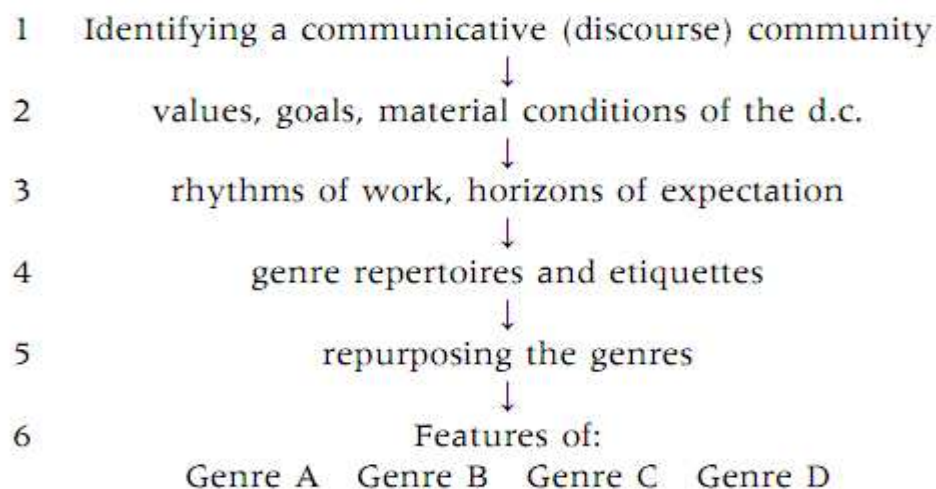

Figure 9. Context-first approach for genre analysis (Swales and Askehave 2001)

Both models show the use of new neologism as ‘repurposing’. The use of such a term is due to the fact that they believe that technological advances made in various fields lead to the emergence of new genres that may be perceived differently and hence need new terms for the analysis. They point out “repurposing encourages [...] and allows attention to focus on the highly contemporary issue of how technological advances affect the way in which genre exemplars are perceived and ranked in relation to their mode of transmission” (Swales and Askehave 2001:209).

The work of Hylland (2000) is a good example that explains the term repurposing. That is, his analysis of book review shows that there is a change in the purpose of the book review during time. The new purposes revealed by the analysis seem to be different from those purposes in the past. For instance, company brochures were simply produced to show the company’s products and services; however, due to technological advances company brochures are now produced to gain relationships with other companies for future business. Therefore, the notion of ‘repurposing’ draws the

analyst attention to the new purposes conveyed by the genre in question. The fact of revealing these kinds of purposes is a reward to the analyst's efforts for discovering them since they are implicitly stated in the genre i.e. they are 'hidden purposes' (Swales and Askehave 2001). As a result, they strongly believe that the notion of communicative purpose as a 'privileged criterion' must be perceived in a different way namely different from that of Swales (1990). Thus, they argue "it is no longer privileged criterion by its centrality, prominence or self-evident clarity, nor indeed by the reported beliefs of users about genre" (Swales and Askehave 2001:210).

Conclusion

There are different views and approaches that try to analyse genre so that to give a much better understanding of its structure and function. In other words, genre is analysed on the basis of taking into account different criteria that help in its identification and classification. Most of the studied based on genre adopt the functional approach which is based on communicative purpose as the primary criterion for the analysis. However, from the above discussion it is shown that we cannot rely only on communicative purpose in the analysis of the different genres. Hence, there are genres that have multiple set of communicative purposes, which raise some difficulties if they are to be classified according to communicative purpose. Thus, it is more convenient to include other factors in the analysis as content, style and audience. Taking these factors into consideration, the analysts can set the appropriate framework upon which the genre is to be analysed.

Chapter three: Technical writing and technical manuals

Introduction

In this chapter, we shed light on the process of writing technical documents as we discuss the different types of technical writings used to develop various kinds of documents for technical communication. Emphasis is put on the types of technical manuals, like proposals, reports and instructions, in order to determine their characteristic features. Thus, the chapter provides a description of ‘technical manuals’ structure taking into consideration their appearance and their content in terms of information type, word choice, sentence structure, and readability.

3.1. Technical writing

In order to understand what is meant by technical writing one must first know the main features of technical writing including readers and audience. Since technical writing uses the written form of the language there must be readers to which these pieces of writing are addressed. In other words, writers and readers are the main participants involved in the process of technical writing. In spite of that the process of writing technical documentation is not as easy as one might think. In fact, technical writing does not only involve writers of technical fields but also illustrators, editors, designers, experts in the field and translators. As Byrne (2006:61) points out “Technical communication is a collaborative process involving technical writers, illustrators, editors, subject matter experts (SME), designers, illustrators, usability specialists and, of course, translators.” This means that the process of writing technical documentation is a very complex one hence it includes the work and effort of a heterogeneous group of people each of which contributes in the process of writing technical documents. Technical writing is not used to entertain the readers but, in fact, to provide them with

technical information that helps them in their everyday life. To put it differently, “technical writing adapts technology to the users” (Dobrin, 1983:247).

As technology advances, more products are produced to assist users in their work or even in their everyday life. However, due to this technological advance the term ‘technical writing’ becomes vague; hence there is the production of new forms of technical documentations. Therefore, the term ‘technical writings’ covers different types of technical documentation. According to National Writers’ Union (1998) there are three main types of technical writings including: technology education, traditional technical writing and technology marketing (Byrne 2006:60).

Technology education: refers mainly to writings about technology addressed to non technical audience i.e. to lay readers. This type of writing includes hard and software manuals, administration user guides, and general interest articles.

Traditional technical writing: unlike technology education, it is devoted to technical audience. That is, readers must have technical background knowledge. Thus, this type of writing produces documents such as repair manuals, programming guides.

Technology marketing: As its name indicates, technology marketing is concerned with the writing of business or sales documentations. In addition to that, this kind of writings is also concerned with writings about technology companies including company brochures and newsletters.

Knowing that, White (1996) believes that the term ‘technical writing’ refers to the process of conveying technical or specialized information to specialized readers as technicians. He argues that “[technical writing is] communicating specialized information in any field (particularly industry), read by technicians, technical managers, owner-operators of machines, and scientific researchers to perform a certain task”

(White 1996:4). Following him, any document that communicates ‘specialized information’ to specific readers is a piece of technical writing since what makes a text technical is its “specialized focus” (White 1996:12).

According to Houghton (1995:6) technical documentations refer mainly to “a collection of documents that explain, describe, and define the purposes and uses of particular software or [a product]”. It is clear that this definition is a broad one since it does not refer to any specific type of documentations. This broad definition may include a variety of documents such as instructions manuals, repair and maintenance manuals, products specifications and presentations. In addition, technical documentation may address a variety of audience, that is, from lay user to engineers and technicians. As a result, technical documentations can be classified, taking, into consideration their ‘specialized focus’, as follows:

- ✓ *Procedural documents* such as assembly instructions, instructions for operation etc.
- ✓ *Descriptive and explanatory documents* such as descriptions of products and services; explanations of processes, concepts etc.; progress reports.
- ✓ *Persuasive or evaluative documents* such as research proposals or engineering projects, product or service evaluations as well as reports recommending actions or policies
- ✓ *Investigative documents* such as reports which are intended to present new knowledge etc.(Byrne 2006:62)

No doubt that the above are various kinds of technical documentations each of which has its own style, content and audience. However, since we are interested in user manuals and instructions, more attention is given to the first type of technical

documentations. In turn, procedural documents are presented in a variety of forms depending on the audience they address and the company that produces them. User guides for households equipments for instance is one kind of procedural documents which contain instructions that tell the reader how to use a given product. Thus, in what follows, the light is shed on the nature of user manuals, namely the technical manuals.

3.2. Technical manuals

Since the technical manuals belong to technical documentations, they vary from general to specific. That is, there are manuals devoted to the public and others to very specific people as technicians. Accordingly, different names and labels are used to describe this kind of technical documentations. These are namely instruction manual, user manual, user guide, operating manual, reference manuals, and repair and maintenance manuals. As far as this research is concerned with user and service manuals we use the term technical manuals to refer to both of them.

To start with, technical manuals according to the Business Dictionary is “a document containing instructions for installation, operation, use, maintenance, parts list, support, and training requirements for the effective deployment of an equipment, machine, process, or system”. In other words, a technical manual is a document that provides instructions for different purposes including using, maintaining, and repairing. In addition, technical manuals are produced in different types depending on the products and the company that produces them. Thus, we can identify different range of technical manuals from a small leaflet that contains diagrams and schemas to heavy booklets with detailed information about the product.

Here, it is worth pointing that technical manuals are also influenced by the technological advances that lead to the emergence of new types of technical manuals. In

other words, manuals are not restricted only to printed documents but they also include electronic ones. Nowadays, many products, such as digital cameras, x-rays machines, computers, phones, satellite TVs, are accompanied with CDs that contain electronic manuals in PDF format, and online help that provides technical information to the user. However, our concern in this study is not its shape or its size, but rather the language including its features and structure. Knowing that user manuals are written in different languages, it is worth mentioning that our primary concern is devoted to those user manuals that are written in English. Scientifically speaking, user manuals are not designed for no obvious reason or for granted; they surely have a certain goal. The critical objective of the user manual is that of communication, namely between the customer and the manufacturer. Since the manufacturer seeks to have a good reputation, the role of the user manual is to ensure that the owner/customer uses the product correctly (Lassen 2003). Thus, “the firm must head off operation errors which cause them higher costs in case of repair and maintenance within the guarantee period”. In addition, the customer will be charged for maintenance costs if the guarantee period is over which leads to dissatisfaction on the part of the customer (Lassen, 2003). Therefore, this cooperation between the manufacturer and the customer depends, to a large extent, on the user manuals quality.

Although technical manuals come in different shapes and sizes, some of them are inadequate and fail to convey the communicative purposes they are designed for. Thus, to a large extent, the success or failure of the company results from the good or bad quality of its technical manual. A good example of the importance of technical manuals' quality is the case of Coleco, which is a computer company. The latter lost 45 million dollars in 1983 due to the bad quality of the manuals as claimed by the customers who returned the products. On the other hand, good manuals are not only to

make the company gain good reputation but also attracting new customers as in the case of Apple Company in the 1970's (Byrne 2006).

To achieve their goals, technical manuals must be organized in such a way that enables the reader/user to retrieve the necessary information easily. With reference to Prince (1984:8), manuals require to be structured according to the users need; he argues that manuals are organized taking into consideration “what I want to do, the tasks I want to accomplish – not what some programmer or engineer thinks. [...] don't make me jump all around the manual just to find one fact”. Therefore, the structure of technical manuals is very important in maintaining communication between the company and the user/reader. There are many things to consider by the technical writers while producing such documents. First, the information in the manuals must be structured in a way that makes the reader/user have an easy access to the specific information. This can be achieved through the use of table of contents, glossaries, and indexes. Second, the manuals must provide the reader/user with full guidance. That is, the information needed to perform the intended task, serves as a step-by-step guide for the reader/user to accomplish his task without confusion. Third, writers must ensure that the choice of language, including vocabulary and style, is appropriate to the reader/user; it is not functional that the reader/user spends time to disambiguate complex sentences. No doubt, the information presented by the manuals must be correct; otherwise it will lead to catastrophic consequences not only on the part of the equipment but also on the part of the company itself.

3.3.Different types of manuals

There are different types of technical manuals including user guides, service manuals, instructional manuals, operational manuals. Each of which is designed to make the

reader/user perform given actions in a particular way. Thus, technicians do not read manuals for pleasure, but to perform their activities in an appropriate way. Depending on their type, manuals provide different type of information to different people. For instance, a service manual includes mostly information to diagnose problems and how to fix them. However, instructional manuals provide information on how to use the product at hand and not how to repair them. In addition, instruction manuals present information to the reader/user moving from general to specific information to make sure that the reader/user does not get confused.

3.4. The Importance of Technical Manuals

The importance of technical manuals is not only in the information they provide but also in the fact that they build a good relationship between the consumer and the company that designed the manuals. However, good relationships depend primarily on the quality of the manuals. Thus, inadequate or poorly designed manuals usually lead to bad consequences and cost the company a lot of money. For instance, in Germany most product return and complaints are due to bad manuals that make the users damaging the product themselves. The cost of damage and compensation can be estimated to 500 million Euros a year. The reason behind these costs is mainly due to European Union laws governing product liability, which clearly states that “inadequate operating instructions may affect the presentation of the products and may be a factor to be taken into account together with all other pertinent circumstances in considering whether goods are defective” (Council of the European Union 1998:1). As a result, manuals in general are considered, by European Union law, as a part of the product. This implies that any defects or mistakes in the manuals are regarded as they are in the product itself (Heino 1992:11). In addition, such defects may result in product replacement.

In order to avoid mistakes and defects, which clearly cost a lot of money, the European Union put defining characteristics to what they believe a good and adequate manual should be like. Such characteristics are clearly described in, what is known as, Resolution C411 (Council of the European Union 1998) under the following headings:

1. ***Development of instructions for use:*** guidelines, standards, laws, etc.
Concerning operating instructions are taken into account. The content is structured on the basis of typical everyday user actions.
2. ***Content:*** operating instructions are set out in a logical sequence reflecting safe practical use. Instructions on safety, cautions and warnings, instructions on installation and, finally, instructions on use are clearly separated from each other.
3. ***Separate operating instructions for different models of the same product***
Operating instructions sometimes include information about different models or versions of the same product. It is advisable to have separate instructions for each individual model, particularly when confusion could constitute a safety hazard.
4. ***Safety instructions cautions:*** instructions, cautions and warnings in matters of safety prominently displayed at the beginning of the operating instructions and use the pictograms which appear on the product itself.
5. ***Language of manuals:*** consumers have easy access to operating instructions at least in their own official community language, in such a way that they are legible and easy for consumer to understand.
6. ***Communication of information:*** the communication of information ideally meets the following requirements: it is sufficiently clear and precise, correct in spelling and grammar, uses comprehensible words, ensures that any illustrations

used correspond exactly to what consumer sees, depict only the necessary information and present only one new item of information per illustration.

7. ***Storage of operating instructions for future reference:*** in order to facilitate home filing and future use, appropriate formats are recommended. Loose leaves are avoided and the layout reflects the order of the information. Fonts are legible for consumers, particularly the elderly.

The objective behind such rules is, as stated by the Council of the European Union, to provide “adequate user information to ensure proper and complete use of the product”. In addition to these regulations, some countries went a step forward, which is the case for Germany. They developed a test certificate known as DOCcert certification. It includes different process tests such as documentation for comprehensibility, completeness, and safety. The tests go through different stages including, checking the relevance of laws, standards and guidelines, testing the manuals in terms of accuracy, testing usability with different users.

3.5. Typical technical documents

Technical writings include a wide range of documents that are produced in different subject areas. Thus, they vary from the simplest products such as children toys to more specific and complex fields as aircraft manuals. The types of documents in the technical field depend on various factors including the nature of the product and the industry within which the company is operating. Although technical documents cover a wide area of subjects, some of them are more frequent than others and, hence, they are considered as typical documents within the field of technical writings. Such typical documents are referred to as proposals, reports and instructions (Byrne 2006:50-51).

3.5.1. Proposals

Whatever the type of the products being described by technical documents, they all started with a simple idea that turned into reality as a product. However, before turning them into reality, ideas need to be proposed whether to research facility, or a company. To do so, proposals are the appropriate way to realise such ideas. Actually, they are a kind of persuasive documents because they are used to convince the concerned authorities to put the proposed idea into production. However, proposals are not a simple piece of writing; they include different types of information that must satisfy the readers' needs. Thus, proposal may include different sections which organise the intended information to the reader such as summary introduction, proposed project or idea, qualifications and experience, budget and appendices (ibid).

3.5.2. Reports

Once the proposed idea is turned into a product, reports are needed to monitor the status of this product in terms of safety, effectiveness and success. Therefore, the main role of a report is to provide facts about the product so that to take the necessary actions appropriately. Depending of the type of information, the type of a report may vary accordingly. That is, a report can represent one of three types of reports, which are informational, analytical, and recommendation report. Each of these kinds of reports is based on the other in a complementary way. While an informational report provides information about the product, an analytical report gives results and conclusions based on the informational report. Based on the analytical report, a recommendation report presents recommendations for future developments and improvements (ibid).

3.5.3. Instructions

Writing instructions is one of the frequent activities in technical writing. They cover various types of documentations. Each type has its own content and audience. They may include instructional manuals, user guides, administration guides, and maintenance and repair manuals. In addition, instructions vary from specific to general depending on the nature of the audience. For instance, instructional manuals can be written for ordinary people as well as knowledgeable ones as technicians. The same thing can be said about administration guides; they may address general workers in the administration as they can be devoted to very specific workers as experts who manage and control the working system of the administration. Although instructions are written to guide people to perform specific actions, they also take into consideration their safety as a priority to avoid any injuries or damage. For this purpose, instructional documents make sure to warn the reader/users in advance about the mistakes that might take place during their actions and how to avoid any risks as results of such mistakes (ibid).

3.6. Genre analysis and Technical Communication

In addition to Swales definition of genre, genre can be explained differently according to different area of research. In technical communication, it is perceived as a recognised way of writing that includes a set of conventions, which determine style, content, and method of communication. Such conventions are shaped by practise and develop constantly (Killingsworth and Gilbertson 1992). According to Killingsworth and Gilbertson (1992:138), “genre is more than just a way of distinguishing among types of documents. It’s a way of classifying and predicting types of actions by determining the rhetoric of documents more closely associated with those actions”. On one hand and with reference to Swales (1992) and Bhatia (1993), communicative purpose has significant importance to determine the moves that shape the genre. As

stated by Swales (1990:10) “it is communicative purpose that drives the language of the discourse community; it is communicative purpose that is prototypical criterion for genre identity, and it is communicative purpose that operates as the primary determinant of the task”. On the other hand, following Eggins (1994:41), communicative purpose in technical documentation, particularly in the case of manuals, is expressed through stages, as he pointed out: “manuals move through stages, each stage having a communicative purpose in terms of the overall goal of the macro-genre”. Sharing the same notion of stages with Eggins, Lassen (1998:105) defines genre in the light of this notion as “goal-oriented social process moving through stages”. To support her view of genre, she suggested four steps to analyse genre of technical documentation such as technical manuals. These steps are identified as: the logic-semantic relations between stages, the schematic structure understood as the staged and goal oriented organisation of the text, the linguistic realizations of each stage, the communicative purposes.

The first step refers mainly to the relationships that exist between the different parts of the text. The second step represents the different stages that express the communicative purposes and shape the text, in this case technical manuals. The third step deals clearly with the linguistic features that characterise each of the identified stages. The fourth stage describes the different communicative purposes that give shape and structure to the technical manuals.

Lassen (2003) gave more attention, in her analysis of technical manuals, to the importance of communicative purposes,. According to her, technical manuals are shaped with different communicative purposes including, to instruct, to inform, to hedge, and to sell. Depending on the type of the manuals, these communicative purposes may not be identified in all manuals. Thus, ‘selling’, is more identified in manuals designed specifically for advertisements than those designed for technical

instructions. Moreover, information in technical manuals is structured through the use of rhetorical functions. With reference to Trimble's EST rhetorical process chart, technical documents as technical manuals are likely to include rhetorical functions represented by Level D. The latter includes description, definition, classification, instructions, and visual-verbal relationships.

3.7.Manuals' Structure

The quality of user manual depends to a large extent on how the manual is structured. Many features interfere in the structure of the manuals from the appearance to the content including style and the choice of words.

3.7.1. Appearance

The first contact between the manual and the reader/user is the appearance. The latter must give a good impression to the reader/user and motivate him to read. Apart from being aesthetically pleasing, appearance makes the reader/user have an idea about the quality of the user manual and the product as well. Thus, the appearance of the user manual is not just the layout of the manual but it also includes the way in which the text is arranged on the pages of the manual (Byrne 2006). According to Houghton (1985),

Each page should invite the reader to read the page, to become involved in the user guide. It is also essential that the appearance of a user guide is consistent with the look and feel of other documents produced by the company as it creates a more professional impression and serves to improve confidence in the product.” (Houghton, 1985:59)

We can consider, then, that the appearance of each individual page is very important in the design of the user manual. Therefore, there are number of things

technical writers must take into consideration in the design and presentation of the pages. These are: simplicity, retrievability, flexibility, readability, paper size, white space, margins, paragraph spacing, and graphics.

Simplicity: the page must be kept simple in the sense that the information can be easily tracked on the page.

Retrievability: the design of the page must help the reader/user to find the information that he is looking for, without any difficulty.

Flexibility: since there is a variety of data in the manuals, the page design must suit all the types of data including company names.

Readability: this is a very important feature because it makes the reader/user read the text easily. Thus, according to Schriver (1997), the printed lines on pages must have a maximum of 8 to 12 words in a line so that the reader/user reads the text easily.

Paper size: although manuals are printed in different sizes, it is recommended to use the appropriate size that accommodates the variety of data presented by the manuals. The choice of size depends on many factors including printing cost on the part of the company and the usability on the part of the reader/user. That is, a large size paper is more likely to increase the expenses of the company and presents a difficulty of use to the reader/user, for instance in a factory.

White space: in fact white spaces in manuals help in maintaining a good readability for the reader/user. As Borowick (1996:132) defines them, they are “any part of a page that is blank and used to separate ideas.”

Margins: apart from leaving a space for binding papers, margins also facilitate the process of reading. That is, they provide a white space that “prevents the reader eyes from running off the end of the page” (Borowick 1996:130).

Paragraph spacing: in order to avoid crowding the page with a lot of information, white spaces must be used between paragraphs not only to separate information and ideas but also to reduce the effort made by the reader/user while reading the text. As claimed by Mancuso (1990:133), “paragraph spacing reduces the amount of fatigue experienced by the reader”.

Graphics: this is one of the most important rhetorical functions in manuals known as visuals. They involve pictures, graphs, charts, tables, diagrams and so on. In terms of communication, graphics are more efficient than texts because they convey information clearly and quickly.

In sum, we can say that manuals appearance is not just about making the manual looking good for the reader/user, but it also defines the way in which the content of the manuals is going to be presented. Thus, content of the manual is going to be described next.

3.7.2. Content

3.7.2.1. Information

Knowing that information is the primary concern of the technical manuals, the manual must provide the reader/user with the necessary information that helps him in operating the machine at hand. Therefore, the structure of the information within the manuals has a significant importance since it determines the quality of the manual. The way in which information is organized not only affects the quality of the manual but also the product and the company as well. That is, if the information is not well

organized it leads to the misuse of the product on the part of the customer. In turn, this will affect the company reputation and cost it a lot of money in case of the product repair. Accordingly, the structure of the information within the manuals depends on many criteria including: the nature of the product, the audience and their background knowledge. Generally, information is structured in user manuals using the following patterns (Byrne 2006:78):

Chronological: this kind of structure is mainly used to provide the reader/user with a sequence of steps that need to be performed in a chronological order.

General-to-specific: it provides the reader/user with background knowledge and a general overview of the machines before he starts reading the instructions. For instance, safety precautions and technical information are generally provided before the reader/user starts operating the machine.

Problem-Methods-Solutions: using this type of structure means that the information is about maintenance and repair. By providing the problem and then the method or the solution to deal with, the reader/user can access to very specific information about maintaining the machine easily and quickly.

Cause-Effect: similar to problem-methods-solution, it is used to provide solutions for the problems that face the reader/user while operating the machine. This kind of information is generally found in the trouble-shooting section. In addition, it is also used to describe the different components of the machine and their functions. For instance, ‘if you push this button the machine will do this and that’.

3.7.2.2. Language

Although the structure of the information is very important in the quality of the user manuals, it is not useful without the appropriate use of the language. Therefore,

even if the reader/user can get the necessary information in the user manual, it is of no value if it is not well expressed through language. Thus, choosing the appropriate language to convey the information of the manual is a very important criterion in assessing the quality of the manual. Of course, the choice of the language depends on some features as the nature of the product being described and the intended audience.

3.7.2.3. Word choice

While it is true that user manuals are more likely to include technical words, it is worth pointing out that the choice of the words depends, to a large extent, on the nature of the audience. That is, words used in the manuals must reflect the knowledge of the audience to which the manual is addressed. Assuming that the audience is familiar with the technical words, the writer may use a high or low frequency of the technical words without confusing the reader/writer. The use of technical words is of great help to both the writer and the reader/user because, on the one hand, these words carry a specific meaning which reduce ambiguity and convey the information appropriately; on the other hand, the use of specialized terminology enables the writer to be more precise and concise and avoid verbosity (Budinski 2001). In technical writing, one of the most important tenets is that “less is more”. This means that the less language used the more ambiguity is reduced. Accordingly, the writer has to reduce the use of nominalization and try to use short sentences as much as possible.

Weiss (1985:148) refers to nominalization as “smothered verbs”. According to him, “the most frequent offenders with regard to verbosity are smothered verbs”. To put it simple, smothered verbs are verbs converted by the process of nominalization. However, even if the writer uses short sentences, the text can be ambiguous if the writer overly compresses the text. In other words, trying to avoid ambiguity does not mean

using excessively short sentences. This consideration makes us consider Ramey (1989) notion of being misled by short sentences due to the fact that they may have a wide range of possible interpretations. To make the image clear consider the following:

- Input mode
- Operating system file specification rules
- Programming error message (Byrne 2006:84)

The above examples are, clearly, instances where the writers try to be precise and concise by using short sentences. However, it is difficult to determine the intended meaning of the writer because these sentences can be understood in different ways. For instance “input mode” can be interpreted in two different ways either as a noun which means that the reader considers it as a state, or as a verb which makes the reader interpret it as a command. Furthermore, the writer has to take into consideration two important elements in the choice of the words ‘redundancy’ and ‘repetition’. These two terms must not be confused. While repetition is used to emphasis or reinforces the information because of its importance, redundancy is a kind of repetition but without purpose. In other words, it is the repetition of the same information in different ways. Therefore, it does not add new information to the meaning of the sentence.

3.7.2.4. Sentence structure

After choosing the appropriate words, the writer has to use them in appropriate sentences that convey exactly the intended meaning. The structure of the sentence that the writer uses has a great influence on the quality of the document. Thus, according to Weiss (1985) the most important information must appear at the end of the sentence because the reader is more likely to remember the last part of the sentence than the first one. For instance, consider the following (Byrne 2006:88):

- The tab marked properties allows users to configure the modem's settings
- To configure the modem properties, click the properties tab.

In this example, we notice that the second sentence is easy to remember, particularly the last part of the sentence “click the properties tab” which includes the imperative mood. As opposed to the first one, in which there is the use of indirect instruction, which makes it somehow difficult to the reader to understand the defined task. In addition, remembering such a sentence is very difficult on the part of the reader/user.

Another point to remember while dealing with sentences is that of parallelism. It implies that the different parts of the sentence that have the same grammatical construction must be balanced following the same pattern. Parallelism is very helpful in writing because it gives sentences more clarity and smoothness. To give it substance, consider the following example:

- a) Customers often call the showroom to inquire about pricing, what items are available, and to place orders.
- b) Customs often call the showroom to inquire about pricing, check on the availability of items, and to place orders. (Rubens 2002:34)

In example (a) the part of the sentence “what items are available” does not balance with the other parts of the sentence. This fact makes the sentence has a jarring effect in terms of clarity and readability. Unlike, the first one, sentence (b) shows a good use of parallelism construction which gives the sentence more equilibrium and makes it easy to read.

Having said that, parallelism is not only concerned with sentences, but also occurs at different levels of constructions including word level, phrase level and clause level as in the case of the following examples, represent word, phrase, and clause parallelism respectively.:

- c) Recommended exercise includes running, swimming, and cycling.
- d) Exercise helps people maintain healthy bodies and handle mental pressures.
- e) Many people exercise because they want to look healthy, because they need to increase stamina, and because they hope to live longer. (ibid)

Another remarkable aspect of sentence structure is the nature of the verb. Verbs are said to be the engines of the sentence because they give action and power to the sentence. However, not all of the verbs have equal value within sentences. Thus, the writer has to choose the appropriate ones to be used in the sentences. To put it differently, verbs tend to be of two types: weak and strong verbs. The difference between the two is based on whether the verb expresses a notion of action or just adds to the meaning of the sentence. Therefore, verbs such as *go, jump, climb, run, and take* are considered to be strong due to the sense of the action they convey. On the other hand, verbs including '*be, do, have, and become*', are considered to be weak because they add little if nothing to the sentence.

The benefit of using strong verbs instead of weak ones is that strong verbs help the reader to understand the information quickly and easily. In addition, they help the writer to be more precise and concise. For instance, consider the following (Byrne 2006:90):

- The function of the hard disk is to allow you store data.
- The hard disk stores data.

Considering these examples, we notice that the second sentence is more precise and concise than the first one. Moreover, it is free from nominalization that may confuse the reader, which is the case for the following examples:

- We performed an analysis on the data.
- We analyzed the data.(Byrne 2006:90)

With fewer words, the second sentence expresses the meaning more accurately in comparison to the first sentence, which uses more words and adds ambiguity to the sentence. That is, the main action in each sentence is “analysis of data”; however it is not expressed in the same way in both sentences. In the first sentence, the main action is disguised under the verb ‘to perform’ since it is considered as the main verb. This consideration misleads the reader from the intended meaning of the sentence which is “the analysis of the data”. Unlike the first example, the second conveys the meaning directly using the verb ‘to analyze’ that provides a direct understanding of the sentence.

3.7.2.5. Imperative

The use of the imperative is, undoubtedly, the easiest and the direct way of expressing the instruction at hand. Leaving no room for ambiguity, the imperative gives no choice but to follow the instructions. For instance, consider the following:

- Install the drivers on the PC
- The drivers must be installed on the PC (ibid:92)

These examples represent the use of the imperative in the active and passive voice respectively. In the first example, the instruction is very clear since the reader/user knows exactly what to do, as he knows that the instruction addresses him and not somebody else. The fact that there is the use of direct imperative means that the personal pronoun ‘you’ is implicitly stated. Although, the second example uses the

imperative it is not clear who is going to carry out the intended action. In this case, the reader/user does not know whether to perform the task by himself or he has to ask a specialist; the reason behind this is the use of the passive voice, which makes the instructions indirect and misleading.

3.8. Readability

Checking the accuracy of the above linguistic features is based on the readability of the text. In other words, word choice, sentence structure, style are all reflected in the readability. The term 'readability' refers to whether the audience understands the text or not i.e. the text must be designed taking into consideration the level of the audience. In terms of assessing the readability of the text, there are different methods, each of which is based on a specific scale that determines whether the text is easy or difficult for the readers. The most used methods of assessing readability are those of Flesch Readability, Fog Index, Lensear Write formula, Clear River Readability and Fry's Readability Graph *First*, the 'Flesch method' is based on the length of words and sentences used in the text. The shorter the word or the sentence is the most likely to be understood by the audience. The scale used to measure the readability varies from 0 to 100 the higher the number, the easier the text tends to be (Escoe 2001).

Second, the 'Fog Index' method focuses on the degree of easy words used in the text. To determine the easy words it makes use of the syllable counting process. Thus, words with one or two syllable tend to be easier than words with three syllables or more, which are known as 'hard' words. The relationship of the sentence length and hard words determine then the degree of readability (ibid).

Third, Lensear Write uses monosyllabic words as a basis to generate his formula which calculates the degree of readability. To be more precise, he uses the following formula (Byrne 2006:93):

$$\frac{\text{The number of monosyllabic words} + (\text{number of sentences} * 3) \times 100}{\text{Total words}}$$

Fourth, ‘Clear River Readability’ includes the number of words per sentence or paragraph. In addition, it makes use of the number of syllable in 100 words length in its process.

Fifth, ‘Fry’s Readability Graph’ is interested in the level of schooling needed to understand the text. By calculating the average of syllables and the length of sentences in 100 words it can determine which level of schooling the text is addressed to (Waterman 2014).

Even though that these methods are very useful in determining which type of the text is best suited for a given audience, they are based on features such as word and sentence length, which may be misleading. That is, we do not know for sure that shorter words are easy to understand because some of the short words can be difficult to understand.

3.9. Usability

In addition to readability, another method to assess the quality of the user manual is to test their usability. The usability deals with users of the manuals themselves in order to determine the effectiveness of the manual. Thus, a good user manual in terms of usability is one that makes the user achieve the task at hand easily. In short, usability is assessing the manual from the user perspective, that is whether the manual is easy to use or not. In fact, usability does not determine only the quality of the

manuals but also determines the writer's achievements in writing the manuals. Taking this into consideration, the linguistics features in terms of style, language and word choice have a great contribution in usability. To put it another way, a good user manual in terms of usability means that the writers have successfully chosen the appropriate linguistic features including style, language and word choice (Olohan 2015).

Since usability deals with users, the simple and easy way of testing this criterion is to gather the appropriate audience for the manual to be tested and making them use the product through the manual's instructions. Following this method, writers can identify the difficulties encountered by the readers/users while reading the manual. Doing so, writers can revise the manual in case there is ambiguity or difficulty in accessing the information.

Conclusion

Technical writing is not a simple process but a complex and collaborative work of different people from different fields. Knowing the complexity of such process, makes it clear how important the information they provide to the reader/user. The writers of such documents make sure that the information provided, to the reader/user, is correct and easily accessed. Thus, to accomplish the readers/users needs, the writers use different rhetorical techniques and strategies to organise the information particularly in specialised documents as technical manuals. Writers of such kind of documents are to make sure that the readers/users use the information provided appropriately so that to ensure their safety.

Chapter four: Research methodology and moves analysis framework

Introduction

The analysis of user and service manuals requires a specific methodology that gives a clear description about the corpus and its characteristics. Our primary concern, in this chapter, is to explain the importance of that methodology and, second, to provide the different steps and tools used to analyse and identify the different moves used to structure both manuals. Third, the chapter provides the type and name of the manual along with the moves that represent it. In addition, it gives the frequency of use of the identified moves for both types of the manuals.

4.1. Understanding corpus

A corpus is a collection of naturally occurring texts, be it spoken or written. However, the collection is not a random one. It is rather systematic and based on given criteria under which the texts are chosen. Since the introduction of computers and due to the large amount of data a corpus can provide, analysing a corpus is more likely to be supported with computer. Taking this into account, the term corpus itself is given specific definition in the sense that it refers to the computerised collection of texts (Nesselhauf 2005:2). In this regard, the corpus used to analyse naturally occurring language is referred to as corpus linguistics. Actually, using a corpus to analyse language is a widely known approach as corpus-based approach. In the field of linguistics, such approach comes with many advantages; hence, it can reveal the frequency of use of each word in the corpus, in addition to providing collocation and concordance. Those advantages are possible due to the nature of the approach that is characterised with the following features:

- ✓ It is empirical, analyzing the actual patterns of use in natural texts.
- ✓ It utilizes a large and principled collection of natural texts as the basis for analysis.
- ✓ It makes extensive use of computers for analysis, using both automatic and interactive techniques.
- ✓ It depends on both quantitative and qualitative analytical techniques, especially functional interpretations of language use.

(Wang 2005:2)

These features give corpus based approach the privilege to be used in many areas of linguistics as lexicography, grammar patterns and register, and dialects as it is the case for sociolinguistics. Corpus linguistics involves various approaches to deal with the data of the corpus. It is an area which focuses on a set of procedure for studying language. The procedures themselves are still developing and remain unclearly delineated set. Corpus approach can be used in many areas of linguistics which distinguish between various types of studies. The latter depend on given features which include (McEnery and Hardie 2012:3):

- ✓ Mode of communication
- ✓ Corpus Vs corpus driven linguistic
- ✓ Data collection regime
- ✓ The use of annotated Vs un-annotated corpora
- ✓ Total accountability Vs data selection
- ✓ Multilingual versus monolingual corpora

4.2. Mode of communication

Corpora can be represented through two forms of language; spoken and written. In addition to these two forms, it may include other forms as paralinguistic features. Taking the written form into consideration, corpora involving such form are easier than what is used to be. Thus, since introducing computer in such area of study, it is possible to treat and store a large amount of data with less effort and time. With the advances made in computer technology, computers can nowadays recognise and display different writing systems of language. However, written corpora are not totally error-free. There are cases that include some errors particularly in the case of scanned documents or typed forms of the original ones. The processes of scanning or typing the original form of the documents entail more possibilities of error occurrence. They are also considered as time-consuming tasks (Smith et al 1998).

Spoken corpora, on the other hand, show more challenge than the written one. The data within such type of corpora involve collection and transcription of the data. Although technology again can solve such difficulty, it raises other issues in terms of reliability. The web, with its huge amount of data, is one of the frequent sources that can be taken in account when building spoken corpora. Hence, data in the web is not necessarily built for linguistic explanation; some analysts try to adopt such data by changing the transcripts a little bit. However, such acts lead to the issue of reliability. According to Mollin (2007:188), such changes affect the data in the sense that “it results in omitting certain interpersonal and situational references as in turn taking in which they present the speaker one after the other without any limitation accounts on how and when to speak.”

Corpora based on paralinguistic features are relatively new. Thus, in some cases the paralinguistic features as gestures are analysed along with speech. For such purpose, videos and textual analysis are required. To do so, many computer programs are developed to achieve such purpose including 'Eudice' and 'Digital Replay System'. Using this kind of software makes it possible to analyse the relationship between gestures and speech. Moreover, corpora are not built using only one form; they can include a variety of forms. For example, The British National Corpus (BNC) is a good example of using two forms of language to build corpora.

4.3. Corpus based Vs corpus driven

Studies that use corpus as a method to explore a theory or hypothesis are referred to as corpus-based studies. However, corpus-driven linguistics is not to be considered as a method alone, but also a source of hypothesis about language (Tognini-Bonelli 2001).

4.4. Data collection regimes

Regardless of whether the corpora are represented through a spoken or written form, it depends on the way in which language data is collected. Data collection, in corpora, is a very important step that needs a lot of attention. Thus, the data must reflect the research questions. Knowing that, various methods are introduced to organise the collection of data including monitor corpus approach and balanced or sample corpus approach.

4.4.1. Monitor corpus approach

It is a corpus that expands over time to include continually more and more texts. It was suggested by John Sinclair as a way to create a data set that expands over time and contains a variety of material. Such type of corpus is best illustrated through the bank of English. It is continuously growing since its creation in 1980 (Sinclair 1991).

4.4.2. Sample corpus

As opposed to monitor corpus, sample corpus is to analyse language in a particular period. The corpus needs to be balanced and representative for a specific period of time, taken into consideration the type of language to be dealt with. As an example of sample corpus, consider language of service interaction of shops in UK in the 1990s. Hence, the period of time is defined as 1990s; the data collected for such a corpus must only include the interactions within such span of time. In addition, interactions can occur in different locations as bookshops, supermarkets and coffee shops. Therefore, the type of shops must be defined so that to give the corpus a defined range of collection (Leech 2007). Defining the range of collection is to ensure the balance of the corpus. That is, when we know the type of shops from which the interactions are collected, balance must be considered through such process. Bearing this in mind, balance is accompanied with representativeness. Thus, the data in the corpus is collected according to given proportions that reflect the number of each type of interaction that the research seeks to investigate.

In spite of that, balance and representativeness are not easy to attain in corpus. In fact, this view is supported by Varadi (2001) according to him corpus' linguists fail to define and realise the balance and representativeness within the corpus. Even the proposals of Biber (1993), who sees such notions are to be realised through the

variability of language, need more consideration in order to be applied. However, it does not mean that these concepts, balance and representativeness are of no value but rather they are, to a large extent, heuristic notions.

4.4.3. Opportunistic corpora

With reference to data collection, corpus can represent and extended, or a specific period of time depending the method of collection. However, there are cases where the collection of data does not follow a defined method as in ‘monitor approach’ or ‘ample corpus approach’. The data collected using neither of the two aforementioned methods is referred to as opportunistic corpora; such kind of corpora does not follow a specific sampling frame. Therefore, the data represents what was possible to collect for a given task. That is, whatever material is relevant to research question and possible to collect is to be included within the corpus (Halliday et al 2004).

4.5. Use of annotated Vs un-annotated corpora

In corpus linguistics, Data can be analysed using a process of encoding that is known as corpus annotation. The use of annotation in corpus can be achieved either by including the analysis within the data or by storing it separately, but it has to be linked to the data. To make it clear, consider the following example: *I heard John's talk and it was the same old thing*. If the research is interested in identifying the grammatical category of each word within the sentence, annotation can be used to make clear each category in the sentence. That is, the word ‘talk’ for instance is a noun that can be represented with mnemonic code ‘N’. Thus, such code can be directly attached to the word within the data using underscore as *talk_N*. In addition, annotations can be used separately from the data in question. To do so, the research needs computer programs to integrate or remove such annotation from the text (McEnery et al 2012).

4.6.Total accountability Vs data selection

While it is true that there are various methods to construct corpora, there are also a number of ways to approach the data built in that corpora. Analysts use corpora to seek answers to their questions or to test a given hypothesis. However, they might not use all the data within the corpora. Thus, they may focus on only the relevant data for their research. This consideration leads to what is known as ‘confirmation bias’ because the analysts focus unintentionally on the data that confirms the theory or the hypothesis at hand. To counter such a drawback, the data must be approached with what is known as total accountability. The notion of total accountability in corpus refers simply to the fact that the researcher must take into account all the data available in the corpus and not only the relevant one to his hypothesis or questions (Vander et al 2011). To put it differently, total accountability is achieved when “the linguistic description of the corpus account for all the relevant obtainable data and not just the examples that the investigator finds useful or congenial” (Svartvik and Quirk 1980:9). As a matter of fact, using the entire corpus is what gives the quantitative features for the corpus-based approaches.

Although total accountability is followed so not to bias the results, it is not always possible to be taken into consideration particularly in the case of very large corpus. Thus, according to Leech (1992:112), when it is practically difficult to use the entire corpus, the researcher has at least to “avoid conscious selection of data”. That is, the research must not select purposely the data or examples that favour his hypothesis or theory. Yet, in given circumstances, focusing on specific data within the corpus is what makes the researcher obtain the answer for his question or even shows the validity of the hypothesis at hand. In other words, total accountability may be irrelevant in certain circumstances and hence the research must shift to what is called data selection. In fact,

data selection is to focus on particular data or specific examples within the corpus. This approach is very useful particularly in the case of what Popper (1934) calls as 'falsifiability' (Garcia 2006). That is, the process of falsifying a hypothesis or a theory. Therefore, in such a case what matters in the corpus is the data that does not confirm the hypothesis or the theory. So, for instance, if the hypothesis is about a specific linguistic feature or pattern that does not generally occur, the most relevant piece of data within the corpus is where this linguistic feature or pattern does occur. Thus, even if it occurs once within the corpus is enough for the research who seeks to falsify the hypothesis. As a result, approaching the corpus to find even a single example to falsify a hypothesis or leading to its revision is a very consistent scientific method.

4.7. Monolingual Vs multilingual corpora

In addition to the various ways of collecting the data and the ways researchers approach it, corpora vary in the language they represent. Thus, another distinguishing feature for corpora is the number of languages they include. Building corpora using only one language makes them monolingual. Considering more than one language in the construction of corpora is known as multilingual corpora. Even when using only one language, a corpus can include very large amount of data, as it is the case for International Corpus of English.

Again, it is worth mentioning that the term 'multilingual' is used to refer to corpus that consists of two or more languages. In this sense, corpus with only two languages, which is namely bilingual corpus, is considered as multilingual (Bowker and Pearson 2002). In addition, monolingual corpus may contain many foreign words; however, it does not mean that it consists of more than one language because such words are, actually, a part of the language in question. Although multilingual corpora refer to more

than one language, confusion may arise while using the term since there are many other types of corpora that can be included under the term multilingual. These types have a common feature which is involving more than one language, they are as follows (McEnery et al 2006:47):

Type A: it includes a source language and a target one. It is generally related to translation because the target texts can be translated in more than one language. The Canadian Hansard is a good example of such a type.

Type B: it refers to a group of monolingual corpora that are built using the same sampling method. For instance, consider the Lancaster Corpus of Mandarin Chinese and Brown Corpus that use the same sampling frame.

Type C: it simply represents the combination of Type A and Type B. For instance, the EMILLE corpora.

Although these three types (namely A, B and C) are related to multilingual corpus, they are perceived differently by scholars. In fact, various terms are used to describe such types. Thus, according to Aijmer (1996) and Granger (1996) corpus represented by Type (A) is referred to as translation corpus while Type (B) is to represent parallel corpus. However, such description differs when considering other scholars as Baker (1993), McEnery and Wilson (2001). Following them, a corpus within type (A) is a parallel corpus whereas the one in type (B) is a comparable corpus. In turn, parallel corpus can represent both types (A) and (B), as suggested by Johansson and Hofland (1994). Therefore, there is diversity of views about which term to be assigned with which type. The differences in using the terms to describe a corpus are not due to variation in the corpus but due to the fact that the same corpus can be described differently by different scholars which is the case for parallel corpus for instance.

Knowing that, the distinction between scholars to attribute the terms that describe each type is due to their differences in the criteria they use to define the corpus. These criteria define the nature of the corpus. For instance, if the number of languages is chosen as the defining criterion for the corpus, it is likely to be described as monolingual or multilingual. However, if the criterion to describe the corpus is content rather than language then the corpus can be described as translation corpus. In addition, the form of the corpus can be taken into account in its description. Thus, if the researcher focuses on the form of the corpus in the description he might use such terms as parallel corpus to identify the corpus in case it contains source and translation texts.

4.8. Description of manuals' corpus

The corpus is built on two types of manuals that will lead to accomplish the objective of this research. They are distinguished as user manuals and service manuals. The selection of such types is due the fact that they address different types of readers or more particularly audience. That is, user manuals are oriented to general public whereas service manuals are designed for technicians. The corpus consists of 30 manuals: 15 manuals represent user manuals while the remaining, that is 15, are service manuals. The common feature between the two types of manuals is that they both represent household equipments. The choice of such category of equipments is based on various reasons. First, unlike the machines or equipments used in factory and industry, they are available and accessible in different forms either printed or electronic. Second, it is the practical size of the manuals. Generally, such types of manuals are average sized with the exception for some equipment that can have booklets of 100 pages. The mean size of each type of manuals is 34 pages for user manuals and 36 pages for service manuals.

As mentioned earlier, the corpus includes manuals that represent household equipments which are used in everyday life to help people accomplishing their desired tasks. Thus, the corpus of user manuals entail the following ones: *vacuum cleaner, air conditioner, tumble dryer, kitchen hood, hair dryer, iron steam, TV set, refrigerator, water heater, washing machine, camera, microwave, dishwasher, sewing machine, and heater*. Service manuals include the following manuals: *vacuum cleaner, air conditioner, tumble dryer, DVD player, cooker, steam iron, TV set, refrigerator, water heater, washing machine, camera, microwave, dishwasher, sewing machine, and heater*. As it can be noticed, service and user manuals represent the same household equipments; however, they do not address the same audience. This consideration helps to compare the results of both types of manuals. That is, by analysing different types of manuals for the same equipment, it is possible to find out whether the difference in audience affects the structure and characteristics of user and service manuals.

4.8.1. Data collection

To facilitate the task of the researcher, the data is collected relying on the electronic form because the printed ones will create additional challenge as they need to be converted to the electronic form in order to be analysed. The electronic form saves time and effort because the manuals are already in PDF format. For more reliability and documents' authenticity, the manuals are downloaded from their official web sites. Since the research is conducted in Algeria, the manuals represent companies that are to be found in the Algerian market as SAMSUNG, LG, PHILIPS and BEKO just to name some. These companies dominate the Algerian market in terms of household equipments. For instance one of these names, at least, is a part of the household equipments an Algerian has at home.

As far as language is concerned, the manuals are only to be in English language. Knowing that these companies sell their product at an international scale, the manuals they produce are based on the English language which gives more reliability to the data. Thus, there is no room for translated manuals because such documents are more likely to include some mistakes, especially at the level of the sentence, which may affect the results. Accordingly, the corpora are monolingual because it is based on only one language, which is English.

Moreover, the collection of data does not take into account when the manuals are produced. In other words, the manuals that make up the corpora do not represent a specific or an expanded period of time as in the 'sample or monitor corpus approach'. Therefore, the collection of data does not follow a specific method of collection but rather it is based on a random sampling. However, random sampling does not mean including whatever manual available. The data must include only the manuals that are relevant to the research questions. Thus, given these points, the corpora is said to be opportunistic.

4.8.2. Method and tools

As mention previously, the corpora consist of 30 manuals representing user and service manuals of household equipments. Since there are two types of manuals involved, they are analysed separately; we analyse the 15 user manuals first, and then we consider the 15 service manuals. The analysis of data goes through two main steps. First we need to analyse the moves used in each type of manuals. Second, we identify the linguistic realisation for each move. In order to determine linguistic features characterizing each of the identified moves, the segments of texts that represent each move are analysed at the level of sentence types and vocabulary.

In the first step, the moves are identified by going through the manuals one by one from beginning to end. Since manuals are already structured using section and sub-sections, identifying where the move stops and where the other starts was rather straightforward. While it is true that information in manuals are organised through sections represented by titles, we cannot entirely rely on those titles because there are sections that include different types of information that require careful attention to determine which move to be assigned with such kind of information. The moves are classified according to the order in which they were identified within each manual. After that, we compare the moves obtained from each manual, namely user manuals, with each other to determine the most frequent moves used in user manuals. Once the most frequent moves are identified, we use them as a pattern of moves that represent user manuals. The same method of identifying and classifying moves is used for service manuals. Next, when we finish the identification of moves in both types of manuals, we compare the results in order to determine if there are any similarities and differences in the pattern of moves used in user and service manuals.

In the second step, the moves are analysed to reveal the linguistic realisation of each move. Thus, this step is more concerned with textual analysis of the data and it is based on two parts including the analysis of sentence types and the analysis of vocabulary. Analysing sentence types is done using annotation. In other words, the identifying sentence types are given codes within the corpus as follows: **i-** for imperative sentence, **d-** for declarative sentence, **r-** for interrogative and **c-** for conditional. Annotating the corpus in such a way helps us to determine the frequency of each type of sentences within the corpus. By doing so, we can find out which sentence type is mostly used to convey the moves in question. The same method is followed while dealing with service manuals. Once the results are obtained from both types of manuals, namely user and

service manuals, they are compared to see whether they have the same distribution of sentence types or not.

With that being said, part two of the analysis is devoted to the nature of vocabulary used to represent each of the identified moves in the manuals. However, to accomplish this part of the analysis we need the interference of the computer since we have a large number of words to be processed. So, to start with, the manuals are converted to text files to prepare them for the analysis through specialised software. In fact, this kind of software cannot accept PDF files; the reason why they need to be converted. In addition, this step enable us to get rid of visuals hence the software process only texts. There are different ways to convert manuals into texts. We can simply save the PDF files as texts using any PDF reader as Adobe Reader or Foxit Reader. However, this method is not error free because in some cases the file is not accurate and cannot be fully converted due to its size. In that case, to avoid such errors during file conversion, we use a genuine PDF to TEXT converter. Since it can only deal with texts, the software eliminates visuals and so the outcome is only a text file. Such files are generally known as NotePad files. Even so, there are cases where the PDF file is an image file. That is, it does not include texts but an image text. For such type of files we cannot extract the texts with “PDF to TEXT converter”. There is a need for another tool called OCR (OCR stands for Optical Character). Thus, it is a tool to extract texts out of image texts. What we mean by image text is that it is a text saved as image so that it cannot be edited in any sort. However, after converting them into texts, one can do all the editing tasks as copying, pasting or deleting sentences or paragraphs.

Once all manuals are converted into TEXT files, they are ready to be processed by the first tool known as ‘Compleat text stripper’. It is worth noting that ‘compleat’ is not a spelling mistake of ‘complete’ but it is the name of this program. The role of this tool

is to refine the input texts of manuals into raw data that will be processed later with another tool. To put it differently, it purifies the data from such elements that can occur within the texts as returns, punctuation, figures, numbers and spaces. Therefore, the outcome of this tool looks like the following:

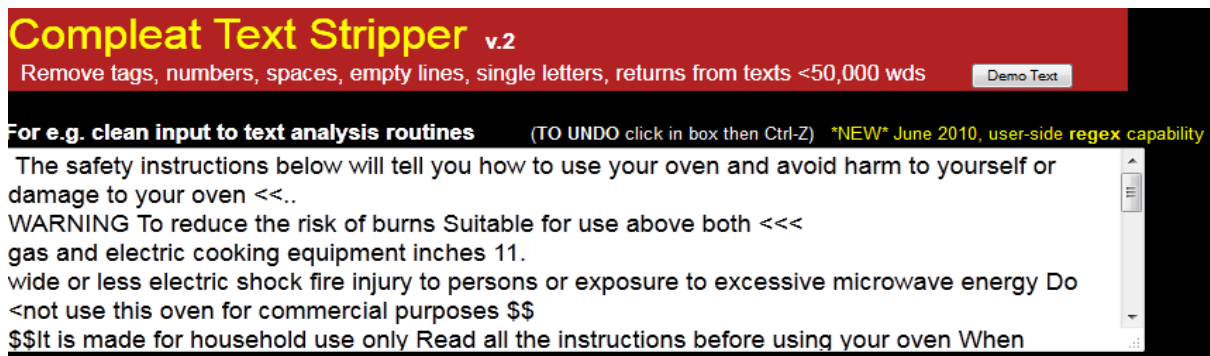

Figure 10. Text before using Text Stripper

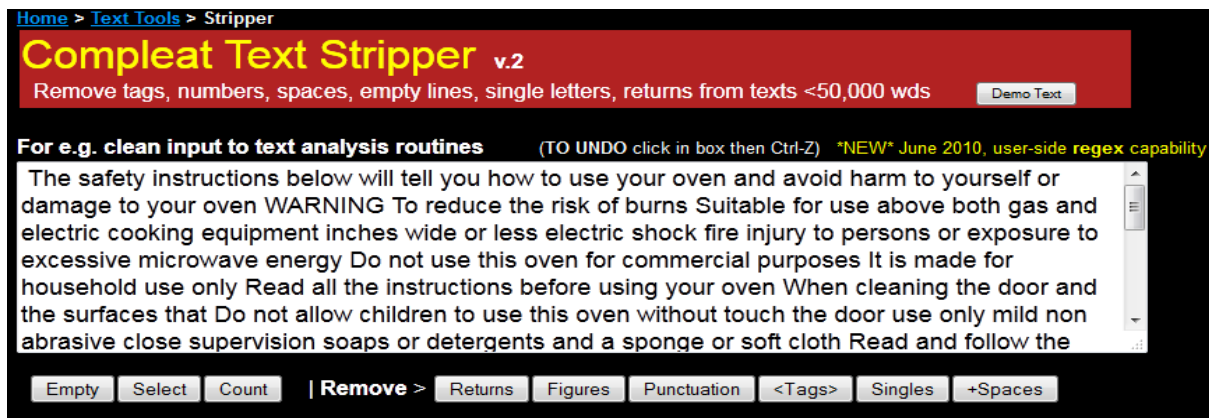

Figure 11. Text after using text stripper

As far as vocabulary is concerned, refining the data with 'Text Stripper' is very important to avoid any unwanted elements within the text that may affect the analysis of the vocabulary. Then, the data is submitted to another analysis tool known as 'Vocabulary Profiler'. Using this tool, we can have a clear image about the nature of the vocabulary used in each of the identified moves. The profiler can identify different

categories of vocabulary including content and function words, academic words, and specialised words generally classified in Off-list words. More particularly, the profiler levels of vocabulary as K1 and K2 that represent general English words. The content and function words are identified in K1. To make it clear consider the following.

	<u>Families</u>	<u>Types</u>	<u>Tokens</u>	<u>Percent</u>
K1 Words (1-1000):	67	74	189	67.99%
Function:	(111)	(39.93%)
Content:	(78)	(28.06%)
> Anglo-Sax	(28)	(10.07%)
=Not Greco-Lat/Fr Cog:		
K2 Words (1001-2000):	18	21	41	14.75%
> Anglo-Sax:	(15)	(5.40%)
1k+2k		(82.74%)
AWL Words (academic):	6	6	18	6.47%
> Anglo-Sax:	()	(0.00%)
Off-List Words:	<u>?</u>	<u>16</u>	<u>30</u>	<u>10.79%</u>
	91+?	117	278	100%

Figure 12. Example of vocabulary profiler analysis of safety instructions

As shown in figure (12) the profiler gives a clear image about the vocabulary used in a text that represents safety instructions. Following the results in figure (12), the vocabulary consists of 82.74% of words belonging to general English; precisely, 67.99% represents K1 and 14.75% K2. In addition, K1 is composed of 39.93% of function words and 28.06% are content ones. The profiler also identified the use of academic words and Off-list words that include specific words that tend to be technical words. Thus, the use of academic and technical words in the text is marked by 6.47% and 10.79% respectively.

4.9.Moves identification in user and service manuals

4.9.1. Moves identified in user manuals

4.9.1.1.LG Vacuum Cleaner

- ✓ Invite the user to read and keep the manual for future reference
- ✓ Warranty
- ✓ Safety information
- ✓ Safety instructions
- ✓ Product description
- ✓ Installation instruction
- ✓ Operating instruction
- ✓ Care and cleaning
- ✓ Troubleshooting

The first move in this manual is to make sure that the user reads the manual before operating the machine and keeps it as a reference in case things goes wrong. The next move is warranty which gives information about the responsibility of the company towards the customer in case there is a problem with the product. It also gives information about the period of time during which the guarantee of the product takes effect. Once reading the warranty terms, the manuals moves to providing instructions. In this move, the manual provides the user with the necessary instructions that enable him to use the product safely; without injuring himself or causing damage to the machine. After that, the manual moves to provide the instructions needed to handle the product, starting from the installation towards operation instructions. In order to keep the product in a good condition, the manual moves on to tell the user how to maintain the product. In this move, the user knows all the information needed to clean the product after its use including tools and chemicals that help him doing that. However, even if there is knowledge of how to operate and maintain the product, things do not always get realised as they were planned. Thus, the product may show some signs of problems that affect its performance. How to identify the potential problems, which

may appear during the product operation, and how to fix them, is all explained in the move of troubleshooting. Following problem-solution method, it provides the user with the possible problems and their solutions.

4.9.1.2.LG Air Conditioner

- ✓ Invite the user to read and keep the manual for reference future
- ✓ Safety information
- ✓ Safety instructions
- ✓ Product description
- ✓ Operation instructions
- ✓ Maintenance
- ✓ Troubleshooting

It seems that this manual has the same move since it starts with the statement telling the user to read the manual and keep it as a future reference. However, the move that explains warranty is not mentioned in the first manual. The reason behind this is that, warranty can be removed from the manual completely but it still included in the product package as a separate sheet. Although it is labelled differently as ‘safety precautions’, it signals the move to safety instructions. Since safety is so important, it cannot be separated from the manual as in the case of warranty. On the one hand, it protects the user and the product itself. On the other hand, it protects the company from liability. Before presenting instructions to operate the product, it moves to providing the user with information about the product including design, names of the different parts that make up the product along with the main function of each part. Knowing the product features helps the user manipulating it easily. So, the move that comes after is the one about operating the product. The move goes through a different set of instructions that guide the user in the operation of the product. Using the product for a long time means that the user has to take care of it. Hence, this move provides the information about maintenance and also provides service information i.e. the information that tells the user

what to do in case of product failure including phone numbers and addresses to contact for advices and repair. However, the user can solve manor problems that occur during the operation or the use of the product; this information is provided in the troubleshooting move.

4.9.1.3. *Beko Tumble Dryer*

- ✓ Introduction promoting the product
- ✓ Inviting the user to read and keep the manual for future reference
- ✓ Safety information
- ✓ Product description
- ✓ Safety instructions
 - Save the instructions
- ✓ Installation instructions
- ✓ Operating instructions
- ✓ Technical specifications
- ✓ Care and maintenance
- ✓ Solution suggestion for problems
- ✓ Guarantee

In this manual a brief introduction occurs right at the beginning to gain the customer confidence by telling him that he chose a good product. This is expressed through a move that promotes the product. Like the previous manuals (1) and (2), the next move asks the user to read and keep the manual as a reference. However, in terms of safety there is a shift from safety information to safety instructions. Although they look like one move they do not express the same thing. Safety information provides the user with the signs and the symbols, used in the manual especially in the ‘safety instructions’, which express cautions and warnings and other potential danger. Therefore, it is difficult to understand the ‘safety instructions’ without knowing what these symbols represent. Considering the next moves, this manual also shows the moves that express the installation and operating instructions respectively. In addition, the manual moves to

technical specifications. To some extent, this move is similar to product description in manual (2); however, it describes the product technically in the sense that the information provided includes voltage, height, weight, and so on. To ensure that the product keeps working properly, it is advised to maintain and take care of it. ‘How to do so’ is found in the move of maintenance. As things do not go always smoothly, the user may face some problems that appear while using the product. Seeking to know how to cope with such problems the company has already suggested solutions for the problems that may occur. Building confidence is very important to the company to gain reputation and increase the potential customers. Guarantee, which is the next move in this manual, helps building such confidence. Thus, when the customer knows that the product has a guarantee period is more likely to encourage him to buy the product.

4.9.1.4. Braun Kitchen Hood

- ✓ Invite the user to read and keep the manual for future reference
- ✓ Safety instructions
- ✓ Safety information
- ✓ Installation instruction
- ✓ Cleaning and maintenance
- ✓ Operating instructions
- ✓ Product description
- ✓ Warranty

Like in the previous three manuals, the first move in this manual asks the reader to read and save the manual for future use. The second move contains the safety instructions that the user must know before handling the product. The move that comes next is that of installation instructions. It guides the user -step by step- to accomplish the task. After the installation, one expects to find the move that contains operation instructions. However, in this manual, both moves, namely installation and operation instructions, are not successive due to the presence of the move cleaning and

maintenance. The reason behind this is that the operation of the product is not so difficult for the user since it is a kitchen hood that needs only a push of a button. However, cleaning the material may seem more difficult than the operation because it includes the disassembly of some parts such as the fan in order to be cleaned thoroughly. The move that indicates the warranty is also present in this manual, even though, sometimes it is separated from the manual.

4.9.1.5. Philips Hair Dryer

- ✓ Thanking the customer for buying the product
- ✓ Invite the user to read and keep the manual for future reference
- ✓ Safety instructions
- ✓ Operating instructions
- ✓ Care and clean
- ✓ Guarantee and service

Thanking the customer for buying the product is the first move, in this manual, as way to establish a good relationship with the reader/user. Then, in the next move, the reader/user is asked to read and keep the manual for future reference. Thus, thanking the reader/user at the beginning will make him more likely to respond to the appeal conveyed by the second move. As it is the case for the previous manuals, safety instructions come next to ensure the safety of both the user and the product itself. The manual goes on to the next move, which is the crucial move in all manuals. This move conveys the necessary instructions needed to operate the product at hand. However, in this manual it is noticeable that the move that expresses installation instructions are not used. Taking into consideration the nature of the product at hand, we can understand the lack of such move. The product is a hair dryer so it does not need installation instructions as in the previous manuals. As a result, what matters here is the operation of the product, which does not require complicated steps or instructions to do it. Again, we notice that Guarantee is not separated from the manual; hence, it is expressed in the next

move along with service information thought both are valuable information needed by the user/reader in case things do not go well.

4.9.1.6. *Braun Steam Iron*

- ✓ Introduction that promote the product
- ✓ Safety instruction
 - Read and maintain the manual for future reference
- ✓ Operating instructions
- ✓ Troubleshooting
- ✓ Maintenance and cleaning

Rather than thanking the customer for the purchase of the product as it used to be in the manuals already discussed, this manual uses a move that promotes the product. In spite of that, this move is also intended to ensure a good relationship with the user/reader. That is, describing the product positively will give the customer the impression that he made the best choice of buying the product. In addition to that, the next move, in this manual, is not devoted to asking the user to read and keep the manual, but rather it is about safety. Although, ‘read and keep the manual’ move is not completely neglected because it is included in the ‘safety’ move. Accordingly, ‘read and keep the manual’ move is considered as a sub move. Thus, in order to use and operate the product safely, the user has to read the manual first. This consideration makes reading the manual as a part of the user safety; that is why it is included in the ‘safety’ move. Like the ‘hair dryer’ manual, this one also does not contain the move which expresses the installation instructions. Due to the nature of the product, in this case it is an ‘iron steam’, such move is not needed. However, after the ‘operating instructions’ move, this manual shows the move of troubleshooting which is not the case for the ‘hair dryer’ manual. Knowing that the product is an ‘iron steam’, it surely needs cleaning and

maintenance which is the main concern of the next move. Furthermore, the manual does not contain the move that expresses guarantee and service like the previous one.

4.9.1.7.LG LCD TV

Invite the user to read and maintain the manual for future reference

- ✓ Safety information
- ✓ Safety instructions
- ✓ Product features
- ✓ Installation instructions
- ✓ Operating instructions
- ✓ Trouble shooting
- ✓ Maintenance
- ✓ Product specifications

‘Read and keep the manual for future use’ seems to appear, again, as the first move. Not differently from the previous manuals, the next move is the one about safety. Before moving to ‘installation instructions’, the manual moves first to a move which deals with the product features namely the components that make up the product and what advantages the product gives to the user. Knowing that, the next move is concerned with the installation of the product. After that, the manual moves towards operating the product by providing step by step instructions that help the user operating the product. Successively, the next move is about the possible problems that may face the user and their solutions. In short, it is about troubleshooting. Without the inclusion of guarantee and service move, the manual goes on to provide the information that helps in maintaining the product, which are represented by the move of maintenance. Last but not least, the manual shows another move about the product which is primarily concerned with specifications of the product as technical information that expresses capacity, voltage, size, and so on.

4.9.1.8.Samsung Refrigerator

- ✓ Product features
- ✓ Safety precautions
 - Invite the user to read and keep the manual for future reference
 - Safety information
 - Safety instructions
- ✓ Installation instructions
 - Product description
- ✓ Operation instructions
- ✓ Cleaning
- ✓ Problems solutions
- ✓ Usage precautions
- ✓ Warranty

Even though it is not usual, in comparison to the other manuals, this one starts with product specifications as the first move. Like the ‘steam iron’ manual, this one uses the move of ‘read and keep the manual’ as a sub move within the move that contains safety precautions. Then, right after, there is the use of installation instructions’ move. Having said that, the move, generally, that appears after is the ‘operation instructions’. Expecting the user to maintain and clean the product, this move provides the necessary information to do so. Assuming the occurrence of some problems with the product, this move presents the required troubleshooting information in order to fix them and prevent their occurrences. At first, the next move which is labelled as ‘usage precautions’ sounds similar to the move devoted to safety at the beginning of the manual. However, when we consider the move carefully, it reveals that the move is, actually, not intended to the safety of the user as such, but to ensure the best use of the product so that to give him better results. The information that appears in this move is about the appropriate conditions under which you can use the product in addition to some tips that help to improve the performance of the product. It seems that, in this manual, there is a

preference to keep the warranty within rather than take it apart as a separate document.

So, the next move used in this manual is to explain warranty terms to the user.

4.9.1.9. *Water Heater*

- ✓ Introduction
 - The purpose of the manual
 - Invite the user to read and keep the manual for future reference
- ✓ Safety instructions
- ✓ Installation instructions
- ✓ Operating instructions
- ✓ Care and cleaning
- ✓ Troubleshooting
- ✓ Product description

While it is true that some manuals start with a brief introduction as a first move, however in this case it is neither to thank nor to promote the product. It, rather, reveals the purpose of the manual which includes the type of the audience the manual addresses. Thus, unlike the other manuals this one is oriented to the installer of the product; namely a qualified person and the owner of the product the general user. Moreover, the move conveys also the need to read and keep the manual for further reference by addressing both types of users the product owner and the qualified person who makes the installation of the product. To have much better understanding of why there is such kind of moves in this manual, we have to take into account the nature of the product. To put it differently, the product being described in the manual is a ‘water heater’ such kind of products needs the interference of a qualified person to do the installation. Otherwise, it will lead to dangerous consequences that may cause serious injuries or even death in the worst cases. That is, inappropriate installation may lead to the explosion of the ‘water heater’ and of course this is the last thing the user wants to happen during the operation of the ‘water heater’. In spite of the fact that we expect the

installer to have a lot of experience and knowledge, the manual expresses the need of reading the manual on the part of the installer to make sure that he becomes familiar with the product features and specifications. When all is said and done, the manual moves to safety instructions that are so important for both the installer and the product owner. Once the safety instruction is expressed, the next move deals with the installation instructions.

When the product is installed properly the owner can use his product safely depending on the operation instructions provided in the next move. Due to their daily use, such products need care and cleaning in order to maintain their good performance. The information that helps the owner to do so are all expressed in the move of maintenance. However, even with maintenance, some products are not always problem-free. There are times when things go wrong in the performance of the product. When this happens, it is time to consider the move of troubleshooting which is likely to contain suggested problems and solutions.

4.9.1.10. *Samsung Washing Machine*

- ✓ Thanking the customer for buying the product
- ✓ Safety information
- ✓ Safety instructions
- ✓ Installation instructions
 - Product description
- ✓ Operating instructions
- ✓ Maintenance
- ✓ Troubleshooting
- ✓ Specifications

Taking into consideration the previous manual of ‘water heater’, this one shows the usual pattern of the previously discussed manuals in which the first move is devoted to thank the customer for buying the product. Knowing this, not surprisingly, the next move is about safety. The safety information is presented first since it includes the interpretation of the symbols and signs used in the manual. Then successively, the manual moves to safety instructions which ensure the user safety during and after the operation of the product. Apart from this, the manual does not include the move that asks the user to read and keep the manual for further reference. Instead, it clarifies in the safety information the responsibility of the company towards the customer. The manual moves to safety instructions where it explains the things to avoid and ensure that the user does not injure himself or damage the product. Keeping in mind these instructions the user can consider the next move which is installation instruction. It contains information such as how to install the product in the appropriate place for a better use. When the installation is done, the user is likely to start operating the product after reading the necessary information found in the next move that explains operating instructions. Without maintenance, the product will probably not last for long; however, cleaning and giving good maintenance helps extending the product lifespan. This

consideration is best explained in the next move of the manual, which is maintenance. As in most manuals, troubleshooting move comes after maintenance. This move, as usual, presents the problem-solution procedure to fix the problems that the user comes across during the product operation.

4.9.1.11. *Sony Handy Camera*

- ✓ Invite the user to read and maintain the manual for future reference
- ✓ Safety instructions
- ✓ Operating instructions
- ✓ Troubleshooting
- ✓ Maintenance
- ✓ Specifications
- ✓ End-user licence agreement
 - Liability
 - Warranty

This manual shows the same, first used, move like the previous manuals. It is the first thing that the user reads in the manual, ‘read and keep the manual for future reference’. After this, the next move is more likely to occur as the ‘safety’ move. Since they are irrelevant for this manual, installation instructions are not included knowing that the manual is about a handy camera. As a result, the move that comes after is about operating instructions without which the user cannot operate the product accurately. If the product seems not to operate correctly, the next move can solve the problem hence it contains troubleshooting information. In addition, the next move helps the user to maintain the product and keep it in a good state because it provides information about maintenance. Moving towards another move, the user finds specifications information. That is, technical information about the product. This kind of information is very important especially to distinguish between different models of the same product. The next move in this manual has a unique occurrence since it does not appear in any one of the previous manuals so far discussed. This move explains the licence agreement

between the user/owner and the company of the product in this case it is Sony. It contains information as not to reproduce the product without permission. In addition, it clarifies the limit of its liability towards the user in case he misuses the product as it states the warranty terms that determine the user responsibility in case of his inability to use the product correctly.

4.9.1.12. *LG Microwave Oven*

- ✓ Invite the user to read and keep the manual for future reference
- ✓ Thanking the customer for buying the product
- ✓ Safety instructions
- ✓ Product description
 - Product specifications
 - Product features
- ✓ Operating instructions
- ✓ Maintenance
- ✓ Troubleshooting
- ✓ Warranty and service

Using the same frequent move as the preceding manuals, this manual starts with ‘read and keep the manual for future reference’. Thanking the customer for buying the product is conveyed by the next move. Expectedly, what comes after is the ‘safety instructions’ move. This move gives the user information about how to use the product correctly in order to avoid serious injuries or damage to the product. Before operating the product, the manual provides the user with a description of the product. The latter involves two sub moves. The first one describes the product in terms of the product specifications such as dimensions and electric energy requirements along with the product model and number. The second one of refers to the product features that entails the name of different component and their function. In fact, this information is very important to help the user operating the product appropriately. Within this in mind, the user can consider the next move which explains the various steps of operating the

product. 'Maintenance move' comes next to make sure that the user maintains his product after its operation. The warranty, which represents the next move, explains to the user the terms under which the warranty takes effect. For instance, according to the company terms, the incorrect voltage, misuse, or operation outside the environmental specifications is likely to violate the warranty terms. In addition, there is service information included within the move that conveys warranty.

4.9.1.13. *LG Dishwasher*

- ✓ Invite the user to read and keep the manual for future reference
- ✓ Thanking the customer for buying the product
- ✓ Safety instructions
- ✓ Product features
- ✓ Operating instructions
- ✓ Care and cleaning
- ✓ Troubleshooting
- ✓ Technical specifications
- ✓ Warranty

This manual, like the other ones, also shows the use of 'read and keep the manual for future reference', which characterises most of the manuals so far. Again, this one includes also the move that thanks the customer for buying the product. After thanking the user, the first set of instructions that the user comes across are the safety instructions. The following move, which is product features, paves the way to the move of operating instructions. Knowledge of the product features will make reading the operating instructions more clearly. The next move is about maintenance; it explains the different steps the user needs to follow in order to clean the product after its use. This process of maintain the product ensures the good performance of the product and extend the product lifetime. Expectedly, after maintenance, comes the move of troubleshooting which, as in all manuals, involves the problem-solution method of solving the problems that encounter the user during the use of the product. Technical specifications are left at

the end instead of the beginning, which is the case in some manuals. They include information about size, weight, and product voltage necessary for the operation of the product. After that, the manual explains the warranty terms that entail the period of time during which the warranty is valid, and indicates the product parts that are under warranty terms in case they need to be changed due to product failure.

4.9.1.14. Brother sewing machine

- ✓ Safety instructions
- ✓ Read the instructions before using the product
- ✓ Thanking the customer for choosing the product.
- ✓ Safety information
- ✓ Product description and features
- ✓ Operating instructions
- ✓ Maintenance
- ✓ Troubleshooting

In this manual, we notice that the safety instructions are used as the first move unlike the other manuals. The second move asks the reader to read the instructions before the use of the product. After that, the manual goes on to thank the user for choosing the product at hand. The next move is about safety which includes all the necessary information to safely use the product. Before using the product, the manual provides the user with all the necessary information about the product, which is expressed by the move of 'product description'. After knowing the product features, the next move the user finds the instructions that guide him throughout the process of operating the product. To keep the product in a good condition, the maintenance move is introduced after the operation instructions. Although, maintenance helps keeping the product in a good state, the product may show some signs of malfunctions. Thus, to fix such problems that interfere in the performance of the product, the troubleshooting move provides the possible solutions to get rid of such malfunctions.

4.9.1.15. De'longhi Heater

- ✓ Safety instructions
 - Read and save the instructions
- ✓ Product description
- ✓ Operation instructions
- ✓ Maintenance
- ✓ Warranty and service

Following the same moves' pattern as the previous manual (brother sewing machine), this manual also starts with safety instructions as the first move, but it does not use the 'read and keep' move as a separate one; instead, it uses it at a sub move in the safety instruction move. After reading the safety instructions, the manual provides product description in the next move as a way to make the user familiar with his product. This consideration helps in the operation of the product. Knowing the product means that the user is ready to use the product; all he needs is the operation instructions that are expressed through operating instructions move. Taking care of the product and giving it good maintenance increase not only the performance of the product but also its service lifetime. It seems that this manual does not include troubleshooting move, which provides the user with problem-solution information to fix the product in case things go wrong. Apparently, it is due to the nature of the product itself -an 'oil heater' that has oil as a heating element. So, troubleshooting such equipment is not easy as one might think; it needs a qualified person to do so. For such a reason the next move provides the warranty information hence it includes the company liability to the product and the terms under which the company makes compensations and spare part replacements in case of product defect. In addition to that, it provides the user with service information that involves the phone numbers and addresses to contact when facing problem with the product.

To sum up, the identified moves in the fifteen analysed user manuals are shown in table (4) which provides the frequency of use in the fifteen user manuals.

Analysed Moves		Frequency in 15 manuals
1	Read and keep the manual for future reference	14
2	Thanking the customer for buying the product	5
4	Safety information	8
5	Safety instructions	13
6	Product features/description	12
7	Installation instructions	7
8	Operating instructions	15
9	Clean and maintenance	15
10	Product specifications	6
11	Troubleshooting	12
12	Warranty	9

Table 4. Frequency of the identified moves in 15 user manuals

The table shows clearly that some of the moves are more frequent than others. In fact, the frequency of the moves indicates how important the move is within the manuals. Thus, moves as ‘safety instructions’ and ‘operating instructions’ are more important than, for instance, ‘thanking the customer move’ in the sense that such moves, safety and operating instructions, express directly the primary communicative purpose of the manuals, which is ‘to instruct’.

4.9.2. Moves Identification in Service Manuals of Household Equipments

4.9.2.1.LG Dishwasher Service Manual

- ✓ Ask the technician to read carefully the manual before servicing the product
- ✓ Safety instructions
 - The audience of the manual
- ✓ Specifications
- ✓ Features and technical explanation
- ✓ Schemas and Diagram
- ✓ Disassembly instructions
- ✓ Troubleshooting methods
- ✓ Installations instructions
- ✓ Exploded view

In this manual, the first move is devoted to ask the technician, as the user of the manual, to read carefully the manual before servicing the product. The next move is concerned with safety where the technician is provided with the necessary instructions that help him in repairing the product safely. More precisely, there is the use of a sub move, which states clearly the type of the audience to whom the manual is devoted; in this case it is the ‘technicians’. Before servicing the product, the technician must know the technical specifications of the product at hand that are conveyed by the use of the next move. In addition to the move of technical specifications, there is the use of ‘features and technical explanation’ move in order to make sure that the technician has a better understanding of the product. After knowing the product thoroughly, the manual provides the technician with the necessary schemas and diagrams that facilitate his job. Knowing the location of the different parts of the product, the technicians can start servicing by disassembling the product. Therefore, this move is about the disassembly instructions. Even though the technician is a qualified person, he faces unexpected things while trying to repair the product. The next move helps him in knowing exactly the source of the problem since it involves troubleshooting information. Once the

problem is identified and fixed by the technician it is time to put things back together i.e. to assemble the product. Installation instructions guide the technician to install the product once it is fixed. The next move is somehow similar to the schemas and diagrams move but the difference between the two is that it does not provide schemas or diagrams, but rather it gives the technician a view about the product and every part included in its composition. This move is called ‘the exploded view’ because the technician can see clearly, in this visual, the internal parts of the product as if they are in a disassembly view.

4.9.2.2.LG LCD TV

- ✓ Ask the user to read safety precautions before servicing the product
- ✓ Safety precautions
- ✓ Service precautions
- ✓ Specifications
- ✓ Servicing instructions
- ✓ Troubleshooting
- ✓ Product diagram
- ✓ Exploded view

In this manual, the first move is used to ask the technician to read the manual, particularly the safety precautions. The next move represents the safety precautions required before starting the repair. To ensure a total safety for the technician, safety precautions are followed with another move identified as service precautions. When safety is ensured, the technician can start servicing the product after reading the technical specifications, which helps him knowing the product better. Servicing instructions comes next; the information presented to the technician is of great importance because they guide the technician through the process of repairing the product. Hence, they include such information as disassembly and installation of the product. If things do not go as planned, the technician can make use of the

troubleshooting information provided in the next move. In this manual, the product diagrams and schemas are placed after troubleshooting instead of putting them right after the servicing instructions. The technician can consult the diagram even before servicing the product whenever he needs it. In addition to the diagram and schema, the technician is assisted, in the next move, with the exploded view in which there is a whole view of the product including its different parts.

4.9.2.3.Microwave oven

- ✓ Read the safety precautions before servicing the product
- ✓ Specifications
- ✓ Safety instructions
- ✓ Audience of the manual
- ✓ Operating instructions
- ✓ Schemas and diagrams
- ✓ Service information
 - precautions
- ✓ Disassembly instructions
- ✓ Troubleshooting
- ✓ Exploded view

Again, in this manual, the first move is to ask the technician to read first the safety precautions before servicing the product. In order to make the technician more familiar with the product it moves to technical specifications required to repair the product appropriately. With a view to make the job of the technician safer, the manual provides instructions about safety. Since the manual addresses technicians, it is not safe for the product owner to try to service the product himself. So, to make sure that only qualified people can service the product, the manual uses the next move to define clearly the type of audience that the manual addresses. In order to fix the product, one must know how the product works. This move gives the operation instructions that can help the

technician doing his job. After that, schemas and diagrams give a clear image about the different components of the product. The information provided by the schemas and diagrams are the most needed ones in repairing the product. While it is true that service information, generally, is about how to service the product, it also includes precautions and tips. In fact, precautions, in this manual, are provided as a sub move of service information. The reason behind this is due to the nature of the product, which is microwave oven, makes it necessary to focus on such information. To put it differently, unlike the other product this one includes radiation which can put the technician in real danger. Accordingly, the technician needs to know the necessary actions to be taken into consideration so that he avoids any potential danger. Bearing this in mind, the technician is ready to service the product safely. So, the first thing to do is to disassemble the product following the disassembly instructions provided by the next move. In case the technician encounters problems while servicing the product, he can consult troubleshooting information. Moreover, the exploded view gives the technician a visual understanding of the product. Again, the manual gives schemas and diagrams that involve a lot of details about the product.

4.9.2.4.Samsung Air Conditioner

- ✓ Precautions
- ✓ Specifications
- ✓ Schematic diagram
- ✓ Operating instruction and installation
- ✓ Disassembly and assembly instructions
- ✓ Troubleshooting
- ✓ Exploded view
- ✓ Wiring diagrams

In this manual, precautions are used as the first move. Thus, there is no such a move that asks the technician to read the manual carefully. Specifications of the product are given next in another move. Also referred to as 'specs', they provide the necessary requirements to be satisfied by the product. If the product does not fulfil the requirements mentioned in the product specifications, it is said to be 'out of spec'. For the technician, such information is very useful because he needs to know the requirements under which the product operates correctly. Similar to the previous manuals, schemas and diagrams are also identified in this manual. Their role is to help the technician to have a much better understanding of the product operation. In addition, they help him diagnosing the problem. Before servicing the manual, the technician needs to know how the product functions. The next move provides him with the necessary instructions about operating the product as well as its installation. Starting the process of repairing means that the technician needs to disassemble the product to see where the problem lies. Without knowing the type of the product, the task of disassembling the product may become troublesome. Therefore, to ensure that the technician disassembles the product in a correct way without damaging any components, the manual includes a move that explains the process of assembly and disassembly. Similar to the aforementioned manual, the troubleshooting move comes after so as to facilitate the task of the technician. Thus, it makes the job quicker and easier. The exploded view is used next to visualize the different components of the product. For more clarity, another move is used in this manual to explain the wiring system of the product, which is represented in diagrams.

4.9.2.5.Samsung refrigerator

- ✓ Product characteristics
- ✓ Installation
- ✓ Specifications
- ✓ Warranty information
- ✓ Product description
- ✓ Disassembly instructions
- ✓ Operation instructions
- ✓ Diagnostics
- ✓ Service safety instructions
- ✓ Schematic diagrams

Rather than using the first move to ask the technician to read the manual, this manual uses it to express the product characteristics. Next, the manual presents information about product installation, which shows how to put the product in place for a proper use. The manual moves to specifications where it gives the technician the technical information about the product to make him more accustomed with the product at hand. Subsequently, the manual moves to supply the technician with warranty information. It states clearly the warranty terms between the owner and the company; it informs the owner about the limited period of the warranty under which the product can be serviced. Moreover, it gives him information about the parts that can be replaced by the company in case of material defect. After that, the manual shifts to a description of the different parts of the product alongside with their names. The next move supplies the technician with the required information to disassemble the product. Once it is disassembled, the technician can go through the different components of the product to diagnose the problem. Operation instructions come next; they help the technician to understand the main function of the product. Knowing that, he can start diagnosing the product to identify the source of the problem. To make things easier the troubleshooting

move gives him the needed information through a consistent method. That is, it gives him the possible sources of the problem that he needs to check. By doing so, he can determine the origin of the problem. It seems that this manual does not follow the usual pattern which places safety instructions at the beginning of the manual. The information provided by this move is a kind of safety measurements to ensure that the product is installed correctly and that the customer is using it appropriately. Schemas and diagrams are provided in the next move. So not to make the technician look for the diagrams throughout the manual, they are placed at the end to make them more accessible.

4.9.2.6.LG washing machine

- ✓ Read the manual before servicing the product
- ✓ Safety information
- ✓ Specification
- ✓ Features and technical explanation
- ✓ Installation instructions
- ✓ Schematic diagrams
- ✓ Operating instructions
- ✓ Checkouts instructions
- ✓ Disassembly instructions
- ✓ Troubleshooting methods
- ✓ Exploded view

In this manual, the first move is used to ask the technician to read the manual before servicing the product. In doing so, the manual seems to follow the same pattern used in some of the previous manuals. As a result, the next move in the manual is concerned with safety information. To ensure safety, this move includes information about the purpose of the manual and the company liability towards the use of the safety information. In other words, the move defines clearly the audience of the manual who can use the presented information. Moreover, it states that the company is not

responsible for the misinterpretation or the misuse of the presented information. This means that in case the owner uses this information to service the product himself, the company is not liable for such misuse. As it is the case in most of the manuals, specifications are used to convey the technical information of the product. Afterwards, the manual gives a description of the product which includes its main features and the names of the different parts along with their functions. In fact, these moves, namely specifications and product description, are intended to make the technician more acquainted with the product. The next move gives him a clear idea about the product installation. It is very important for the technician, before he starts to service the product, to make sure that the product is installed appropriately. Thus, in case the product is not installed properly the technician will know immediately. Next, the manual provides the needed schemas and diagrams to repair the manual. They are indispensable information for the technicians because they give them a clear image of the product internal components. The next move in this manual is to give the technician information about operating the product. Having understood how the product functions, the technician is ready to service the product. Thus, the next move provides him with the required instructions to disassemble the product and start diagnosing the possible problems. Troubleshooting information conveyed in the next move gives a good assistance to the technician in the repair of the manual. In addition to that, the manual gives a visualized view of the product including its components. This consideration is realised in this move which gives an exploded view of the product.

4.9.2.7. Garland Induction Cooker

- ✓ Safety information
 - Audience of the manual
 - Read the manual before servicing the product
- ✓ Technical information
- ✓ Operation instructions
- ✓ Maintenance
- ✓ Fault finding
- ✓ Service instructions
- ✓ Schematic diagrams

In this manual, safety information appears as the first move. Apart from making the technician familiar with the signs and symbols used to express warnings, caution and danger, it includes a sub-move that provides information about the intended audience of the manual as a safety measurement. Thus, using the manual to service the product by unqualified person may lead to bad consequences on both the user and the product. Thus, to avoid such consequences, it is very wise to define the audience of the manual right at the beginning. Besides, there is another sub-move, in safety information, that asks the technician to read the manual before attempting to service the product. Keeping this in mind, the manual moves on to give the technical information of the product which distinguish it from other products of the same class. As a part of the repairing process, the technician has to know the different steps to operate the product at hand before he starts the repairing task. Therefore, the next move is about the operation instructions without which the technicians will face difficulties in the repairing process. Why so? Before the repair, he needs to operate the product to have a general idea about the kind of the problems interfering with its performance. Moreover, in this manual, there is the use of another move that explains maintenance steps that need to be performed by the technician himself. The steps explain the different points to be

checked within the product to ensure a trouble free operation. In addition, it states how often the maintenance task must be carried out during the year. Troubleshooting comes next as a step to help the technician identifying the problem within the product. Once the problem is identified, the technician moves to the repairing process that is explained in the next move as servicing instructions. In addition to that, the next move presents important assistance to the technician hence it gives him a clear and detailed view of the product through the use of schemas and diagrams.

4.9.2.8.Daeivoo DVD Player

- ✓ Specifications
- ✓ Promoting the product
- ✓ Operational description
- ✓ Schematic diagrams
- ✓ Disassembly

The manual starts with the specifications of the product as a first move. After that, it provides information about features and advantages of the product in a way that seems to promote the product. The next move is devoted completely to the description of the product in terms of its operation. It explains, in a descriptive way, how the product functions as a whole as it explains the function of each part of the product. Schematic diagrams come next; they give a better understanding of the product and its internal components. They do not only include simple wiring diagrams but also diagrams about the internal circuit used in the product. To put it differently, this move provides also diagrams about printed circuits board; generally they are referred to as PCB. Subsequently, the manual provides the disassembly instructions mostly needed by the technician in the repairing task.

4.9.2.9. Bradford White water heater

- ✓ Introduction
 - Product feature
 - Audience
- ✓ Troubleshooting
- ✓ Servicing instructions
 - Disassembly instructions
 - Assembly and installation
- ✓ Exploded view

The first move used in this manual represents an introduction, which explains, through two sub-moves, the main features of the product and defines the target audience of the manual. After this, the manual gives a clear understanding of the different steps needed to troubleshoot the product in question. This kind of information helps the technician to determine the cause of the problem and guide him through the repair task. Afterwards the technician is more likely to start repairing the product. This move, which is mainly about the servicing instructions, explains the process of the repair by providing the disassembly and assembly instructions as well. For more clarity, the manual contains a visual understanding of the product including its constituent parts. Thus, the next move in the manual is devoted to the exploded view of the product. By placing it at the end of the manual, the information expressed by the exploded view can be accessed easily and quickly whenever the technician needs it.

4.9.2.10. LG tumble dryer

- ✓ Read the manual before servicing the product
- ✓ Safety information
 - Audience of the manual
- ✓ Specifications
- ✓ Product description and features
- ✓ Installation instructions
- ✓ Maintenance instructions
- ✓ servicing instructions
- ✓ Schemas and Diagrams
- ✓ Troubleshooting
- ✓ Disassemble instructions
- ✓ Exploded view

The manual proceeds by using the first move to ask the technician to read the manual before servicing the product. The next move in the manual is not only about the safety of the product but also about the safety of owner through the use of a sub-move within safety information. Thus, it states clearly, as a safety measurement, that the information given by the manual is intended for a qualified person i.e. the technician responsible for the repair. Specifications of the product are given in the next move so as to make sure that the technician understands the product requirements in terms of product type, capacity, current voltage and so on. Subsequently, the manual provides a full description of the product including its main features. In addition, it covers also the name of the different parts and their function. For a good result, the product must be installed properly by the technician. The next move helps him in doing so hence it provides the necessary instructions to install the product. Afterwards, the manual gives instructions to clean and maintain the product in a good condition. This move intends to give the technicians the main point to be checked during the year to ensure the good performance of the product. Although, maintenance is a part of the owner duty, the technician has to check them himself so that to reduce zone of suspicion. Thus,

neglecting to maintain the product is one of the reasons that lead to product failure. Knowing this, the manual goes on to provide the instructions that explain the steps to be followed by the technician in order to service the product correctly. Moving forward, the next move provides the mostly needed piece of information that helps the technician in his task. Such information is conveyed by the use of schemas and diagrams. In fact, they are indispensable assistant for the technician. In addition to that, the technician can make use of the information provided by the move of troubleshooting. To access the internal components of the product, the technician has to disassemble the product first. Thus, the instructions required for the disassembly are provided by the next move. Furthermore, in case the technician faces problems in the disassembly process he can check the next move which provides him with an exploded view of the product. The purpose of this view is to give clear image about the product's internal components.

4.9.2.11. Brother sewing machine

- ✓ Read the manual before servicing the product
- ✓ Safety information
- ✓ Safety instructions
- ✓ Specifications
- ✓ Product description
- ✓ Disassembly instructions
- ✓ Assembly instructions
- ✓ Troubleshooting
- ✓ Schemas and diagrams

Like many manuals discussed previously, this one also starts with the move that asks the technician to read the manual before servicing the product. The next move is used to express information about safety; it explains the symbols used in the manual in addition to the ones used on the product itself. Knowing how to interpret these symbols, the manual goes on to provide safety instructions in the next move. In fact, safety

instructions are the steps to follow in order to avoid serious injuries or damage to the product. Taking the safety measurements into account, the next move provides the product specifications. For an accurate service, the technician needs to know such specifications as the product model and the product performance in terms of capacity. However, the technician needs to know more than the specifications of the product so that to accomplish his task appropriately. That is, he needs to know the different parts of the product including their names and functions. This kind of information is to be found in the next move, which gives a thorough description of the product. In many cases of repair, the technician is for sure to disassemble the product to reach the internal components. Thus, without this step the task of repairing the product cannot be accomplished. So, the next move is concerned with product disassembly. Although the next move, which is about assembly instructions, is not used in some of the early discussed manuals, this one uses it as a way to ensure that the technician puts things back correctly. The reason why it is not used in all manuals lies in the fact that the assembly process is just the reverse of the disassembly one. That is, if the technician knows the way to disassemble the product, it implies that he also knows how to assemble it. Having said that, troubleshooting comes next to facilitate the repairing task. It gives the technician the correct diagnosis method to determine the source of the problem. Moreover, he has the assistance of schemas and diagrams that enable him to locate the product components easily. The latter is provided by the next move of schemas and diagrams.

4.9.2.12. Philips steam iron

- ✓ Product feature
- ✓ Technical information
- ✓ Exploded view
- ✓ Schematic diagram
- ✓ Disassembly instructions
- ✓ Exploded view
- ✓ Disassembly instructions
 - Safety information

This manual starts with a move that explains the main features of the product. After that, the next move gives the technical information of the product. In fact, technical information used in this manual is to convey specifications of the product. Next, the manual provides an exploded view of the product. This one is intended to give assistance to the technician through visualising the different parts that make up the product. In the exploded view, the components are distanced from each other in a way that shows how they fit together as a whole. By doing so, the exploded view gives a clear image about the assembly of the product. Furthermore, in the next move, the manual shows the schematic diagrams of the product. This move instructs the technician about the interconnections of the significant components that make up the product. Bearing this in mind, the technician can move to disassemble the product so that to repair the defected parts. The disassembly of the product requires from the technician to go through a different steps. These steps are explained in the next move which is concerned with disassembly instructions. It seems that, in this manual, there is the repetition of the same move hence the next one is also about the exploded view. To make it clear, it is worth mentioning that the use of the exploded view twice is not a kind of repetition but rather it is a necessity. In fact, this product, steam iron, is composed of two parts. The first part of the steam iron is represented by the first exploded view; the second part is the stand of the steam iron. Therefore, the move that

comes next is the disassembly instructions of the iron's stand. In fact, the disassembly instructions of the stand also contains some kind of safety information which is intended to guide the technician so that he does not damage the product, because it is fragile, as well as not to hurt himself while servicing the product.

4.9.2.13. Samsung mobile phone

- ✓ Safety precautions
- ✓ Specifications
- ✓ Product features
- ✓ Installation
- ✓ Exploded view
- ✓ Disassembly instructions
- ✓ Assembly instructions
- ✓ Schemas and diagrams
- ✓ Troubleshooting

This time the manual opens the flow of service information by the use of safety precautions as the first move. Due to the delicate nature of the product, the safety precautions provided in this move are meant to make the technician not to damage internal components of the product during the repairing phase. After that, the manual is to provide the product specifications. It is very helpful to know the product characteristics so that to differentiate it from the different models the product may have. In addition to that, the manual also gives the main features of the product which are explained in the next move by providing the main advantages of the product that cannot be found in other products. Knowing what the product is capable of, the manual moves on to present the installation instructions. The importance of knowing the installation instructions is not only for the operation of the product, but also to help the technician in the repairing task. Since the manual represents a mobile phone, the installation instructions meant here are those of installing the necessary drivers in the computer in order to establish connection between the phone and the computer. Knowing that the

product has software, it is also the duty of the technician to check for errors in the software before he moves to work on the hardware. With that being said, the manual provides the exploded view to explain, visually, the disassembly and assembly process. Having a good understanding of the different components of the product in the exploded view, the technician can proceed to disassemble the product following the instructions provided in the next move. Although this kind of moves is needed after finding and fixing the problem, the manual also supplies the technician with the assembly instructions so that to ensure a proper assembly of the product. Successively, the next move gives the necessary diagrams; they are the essence of the service manual due to the significant assistance they provide to the technician. In addition, another helping hand to the technician is the information provided in the troubleshooting move.

4.9.2.14. Sony handy cam

- ✓ Specifications
- ✓ Safety information
- ✓ Service instructions
- ✓ Disassembly instructions
 - Exploded view
- ✓ Schemas and diagrams
- ✓ Exploded view

In this manual, the first piece of information is to provide the technician with the specifications of the product. Because of their significant help to the technician, they are placed at the beginning of the manual. Safety information is placed as a subsequent move. The reason for such arrangement is that, in this manual, safety information is more concerned with the safety of the product than the safety of the technician himself. Since the product at hand is a recording camera, the technician is more likely to deal with very small electronic components that can be damaged easily with the smallest mistake. Bearing this in mind, the next move gives him the must know steps that ensure

accurate repair. These steps are explained in the service instructions move. Sure enough, the technician needs to take apart the product to start the necessary repairs. Therefore, the next move conveys the required instructions for the disassembly process. In addition, the disassembly instructions use the exploded view as a sub-move to explain the process of disassembling the product. Thus, it instructs the technician graphically through the use of the exploded view. The latter contains the main parts of the product that need to be disassembled first. To make things easier, the manual offers to the technician, in the next move, the necessary schemas and diagrams that help him find easily the interconnections of the components. Another exploded view is used in this manual as a kind of support to the technician because the first exploded view, as explained, was used to show only the main parts of the product. As a result, this additional exploded view is to provide the details of the main parts of the product by decomposing them into their constituent components. In doing so, the technician can see each component individually in the exploded view. This consideration helps him to assemble the product accurately.

4.9.2.15. LG vacuum cleaner

- ✓ Read the manual before servicing the product
- ✓ Safety precautions
- ✓ Product description
- ✓ Specifications
- ✓ Disassembly instructions
- ✓ Troubleshooting
- ✓ Schemas and diagrams
- ✓ Exploded view

In this manual, the first move is used to ask the technician to read the manual before trying to service the product. As he moves forward, the technician is supplied with significant information that ensures his safety as well as the product safety. Such information is conveyed through the safety precautions. They intended to prevent

unwanted actions on the part of the technician that may lead to injuries or damaging the product. After that, the next move gives a description of the product in the sense that it presents the product form and design including the different parts of the product along with their names. The advantage of such a move is to make the technician more familiar with the model of the product he is dealing with. Due to the competition between companies within the market, there are different types and models of the same product. Therefore, to ensure that the technician knows exactly which type of product he is supposed to repair, the next move leaves no room for confusion hence it provides him with product specifications. Clearly, they include the product type, product dimensions and the nature of the power source. The disassembly instructions come next and include the tools to use and the steps to follow so that to take apart the constituent pieces of the product. Moreover, the technician is also assisted with the troubleshooting information. It is very useful to determine the cause of the problem because it uses from-general-to-specific method. That is, it tells the technician what components to check first to reduce the scope of suspicious before dealing with delicate and specific ones. To give a better understanding of the wiring system and the main interconnections of the different components, the next move is responsible for providing such information, which is identified as product schemas and diagrams. In addition, this manual gives more support to the technician through the use of the exploded view. Using a visualised image of the product and its internal components helps the technician throughout the repairing task particularly in the disassembly and assembly steps.

After analysing the fifteen service manuals, it is clear that they use different moves to convey information to the user, in this case technician. In addition, the identified moves differ in their frequency of use throughout the manuals. To make the image clear, the

following table (5) includes all the identified moves along with their frequency of use in the fifteen analysed manuals.

Analysed Moves		Frequency in 15 manuals
1	Read the manual before servicing the product	8
2	Safety instructions	9
3	Safety precautions	4
4	Specifications	14
5	Audience of the manual	6
6	Product description/features	10
7	Installation instructions	6
8	Operating instructions	6
9	Servicing instructions	6
10	Schemas and diagrams	14
11	Disassembly instructions	13
12	Troubleshooting	12
13	Exploded view	12

Table 5. Frequency of the Identified Moves in Fifteen Manuals.

The table shows the frequency of the moves used in service manuals which reflect their importance in structuring service manuals. Thus, moves, as schemas and diagrams, that are directly related to the primary communicative purpose of the manual, which is to repair, are more frequent than moves that indirectly convey the primary communicative purpose, such as ‘operating instructions’.

Conclusion

The discussion of the identified moves made it clear that there are different patterns of moves used to structure information in both types of manuals, namely user and service manuals. It is shown that the moves tend, to great extent, to follow the same order in structuring the manuals regardless of its type and nature, for instance asking the user to read the manual, in most of the times is followed by presenting safety instructions. In addition, the use of moves through the analysed manuals shows that there are moves more frequent than others moving from manual to another.

Chapter five: Linguistic Features of Moves in User and Service Manuals

Introduction

This chapter is to shed light on the linguistic features that are used to convey the different moves that structure user and service manuals. It provides a description of the linguistic realisation for each move separately. The latter is presented taking into consideration the different lexical sets and sentence types that communicate information through the identified moves. We will first explore moves' linguistic features in user manuals, and deal with service manuals as a second step.

5.1. Linguistic features of moves in user manuals

5.1.1 Read and keep the manual for future reference

A	Please read this manual carefully before operating your set and retain it for future reference.
B	Please read the Operation Manual before installing and starting your machine.
C	"Read all instructions before using."
D	Read these instructions thoroughly before using this heater.
E	Read this user manual carefully before you use the appliance and keep it for future reference.
F	Before using the iron, read the use instructions completely. Keep the use instructions during the entire life of the iron.
G	Please read this manual carefully before operating your set and retain it for future reference.
H	Please retain this owner's manual for future reference. Read and follow all safety rules and instructions before using this product.
I	PLEASE READ THIS OWNER'S MANUAL THOROUGHLY BEFORE OPERATING.
J	Please read this manual carefully before operating your set. Retain it for future reference.
K	After reading these owner's instructions, please keep them in a safe place for reference.
L	Before operating the unit, please read this manual thoroughly, and retain it for future reference.
M	It is imperative that all persons who are expected to install, operate or adjust this water heater read the instructions carefully so they may understand how to perform these operations.
N	READ AND SAVE THESE INSTRUCTIONS

Figure 13. Different instances of the first move 'read and keep the manual'

The above figure (13) shows different instances of how the first move is expressed in different user manuals. The move is identified as ‘read and retain for future reference’. Clearly, not all the manuals express the move in the same way. Thus, we notice that there is a diversity of structure used to express this move. The message of the move is conveyed by the use of imperative, which means that the sentence entails a sense of ordering. As a result, some of the manuals preferred to use “please” to soften the imperative, which is more polite. In our analysis we find that there are 8 instances out of 14 manuals, which use this move with the word “please”. In addition, the use of such a word makes the reader more likely to respond hence it represents an appeal rather than an order. The use of the imperative makes the reader know that he has to read the instructions carefully. However, there are cases where declarative sentences are used instead of the imperative as in the case of (M) where it states “it is imperative”. Even without using the imperative, the sentence expresses clearly that the user/reader ‘has to’ read the instructions. In fact, the verb ‘read’ is used in the imperative mode more frequently in the manuals to express the first move; the verb ‘read’ is one of the most frequent keywords in the first move.

After using the verb ‘read’, it is expected to mention what to read. Since ‘read’ is concerned with the manual, we expect such a word as ‘manual’ to follow the word ‘read’. However, considering what comes after the word ‘read’ shows that there is a variety of words. It appears from our analysis that there are 7 instances where the word ‘manual’ follows the word ‘read’. However, even within the 7 instances there are other words that modify the word manual as ‘user’, ‘owner’, ‘operation’. So, the word ‘manual’ does not come directly after the word ‘read’. The other instances show that the word ‘read’ is followed also by such word as (these, all) ‘instructions’. However, there is also a possibility of another verb to follow ‘read’ as in the instance of (N) where the

word 'save' is used after 'read'. Even though so, the word 'instructions' still appears after the word 'save'.

Knowing what to read (manual/instructions), the sentence goes on to state how. This is achieved mainly using adverbials such as 'carefully', 'thoroughly', and 'completely'. In essence, the most used adverb is 'carefully' with a frequency of (5) times in the overall manuals. Although, 'thoroughly' and 'completely' are to mean the same thing, it seems that 'thoroughly' is preferred hence it shows (3) times of uses as opposes to 'completely' which is used only once. In addition, it appears that on the one hand the word 'carefully' is only used when there is the word 'manual'. On the other hand, the words 'thoroughly' and 'completely' are used with the word 'instructions'. To give it more clarity, we do not expect the reader to read the entire manual from cover to cover. Therefore, using the words 'thoroughly' and 'completely' with the word 'manual' will make it sound like the reader is forced to read the manual. This consideration may lead to dissatisfaction on the part of the reader that makes him give up reading right at the beginning. Therefore, the word 'carefully' is more suitable in the sense that the reader/user does not need to read the manual completely. It implies that he has to pay attention while reading the manual particularly to such information as safety instructions. However, the word 'carefully' can be used with the word 'instructions' hence instructions are of great significant in the manual. Although, this is true, the word 'carefully' does not imply 'complete'. Thus, the reader/user can read carefully the instructions without going through all of them. So, the reader/user has to read thoroughly/completely the instructions particularly those of safety. The reason why 'thoroughly' and 'completely' are used with the word 'instructions'.

Following such structure, the reader/user is to expect why he is supposed to read the manual. However, the sentence does not contain the purpose for which the

reader/user has to perform the defined action, at least not explicitly; the purpose is stated implicitly through the use of 'before' clause. In addition to its use as adverb and preposition, 'before' can also be used as conjunction. In this sense, it entails that the sentence contains two actions; one needs to be performed before the other. Since 'reading' is the first action what comes after 'before' is the second one. Considering these manuals, the second action to be performed is expressed by the use of two words namely 'operating', 'using', 'installing', and 'starting'. In terms of their frequency in the manuals, they show (5), (4), and (1) occurrence respectively. Considering their frequencies, the most prominent words are 'operating' and 'using'. Although, to some extent, they have the same meaning, they do not express exactly the same thing. According to Longman dictionary (2009) 'operating' from the verb 'to operate' means "to use and control". However, 'using' (from 'to use') means "you do something with a tool, method, for a particular purpose". To put it differently, the reader has to read carefully the manual before operating the machine implies that, in order to use and have full control of the machine at hand the reader/user has to read the manual. In addition, reading the manual 'before using' the machine entails that the reader/user must read first the instructions so that to use the machine correctly. Since 'use' means to use something for a particular purpose, it implies that the reader/user has to use the machine only for its intended purpose. Knowing that, it is worth mentioning that the words 'operating' and 'using' co-occur with the words 'manual' and 'instructions' respectively. Thus, the analysed manuals, which contain this move, show that there are 5 instances where the word 'operating' co-occurs with the word 'manual' and 4 instances where the word 'using' co-occurs with the word 'instructions'. Moreover, the remaining manuals reveal that there are 2 instances where the words 'operating' and 'using' are not used at all. The other ones include 1 instance in which the word 'operate'

goes with 'instructions', one occurrence of the word 'use' with the word 'manual', and one case where the words 'manual' and 'installing and starting' appear together.

Bearing this in mind, the word 'manual' is used along with the word 'operating' in order to convey to the reader/user that the use and control of the machine, implied by the word 'operating', requires a careful reading of the manual as a whole. So, it is not enough to read only some of the instructions in the manual to really control the machine. On the other hand, 'instructions' is related to the word 'using' in the sense that the reader/user can use the machine for its intended purpose without the need to read all the instructions in the manual. For instance, he can only read the safety and operating instructions, whereas in the case of 'operating' he has to read all the instructions in the manual, so that to control fully the machine, including installation, maintenance, and troubleshooting instructions.

In spite of that, the meaning of the word 'instructions' may vary from general to specific depending on the move in which it is used. Thus, when used in the first move right in the front of the manual, it has more generic meaning and conveys the meaning of reading all the instructions. However, when used as a sub move in, for instance, safety information, it has a specific meaning that refers mainly to the instructions about safety.

Another point revealed by the analysis of the manuals is the occurrence of 'you', 'your', and 'owner'. They intend to give an idea about the type of the manual and the user of the machine. Although the type of manual discussed here is the owner manual, there are different names used to refer to the manual of this type for instance instruction manual, user manual, and operation manual. All of these, in fact, are to address the owner of the product who is generally referred to as 'lay user'. Since the purpose of this

type of manuals is to instruct the owner how to operate the machine, it is written in a way that assumes that the owner does not have a specialized knowledge about the machine. Therefore, the use of the aforementioned words helps to identify the manual as owner manual. Besides, the word 'your', which indicates possession, makes sure that the reader/user uses the manual only to operate the machine mentioned in the manual and not another machine of the same type. Although the word 'you' is implied by the use of the imperative mood, it also appears in some of the analysed manuals. The use of such word is intended to convey that the machine is to be used by 'you' as the owner of the machine hence the manual address the owner as a layman and not someone else as an engineer or a technician.

In addition, there is the use of 'this' and 'these' with the words 'manual' and 'instructions' respectively. They are used to stress the fact that the reader/user reads the manual/instructions that comes with the product and not another manual which may describe the same product. Knowing that, they are also used to point to the product at hand that the manual comes with and not another product of the same type. For instance, notice the use of 'this' in (D), namely "...this heater", to refer to the actual heater at hand. Thus, it implies that the manual cannot be used to operate another heater even if they are similar to each other. There is also the use of definite article 'the' in (E), "...the appliance", in order to refer to the actual owner appliance and not any appliance. As a result the manuals show that the words 'this' and 'the' have the same frequency of use of 11 times for each.

Apart from determiners and definite articles, the sentences that express this move also contain conjunctions. The most frequent one is 'and' with 8 occurrences. The use of such coordinating conjunction means that the sentences are more likely to be compound ones. In addition to that, it implies that both clauses, since it is a compound

sentence, are of equal importance. Knowing that, the reader/user has to perform both actions conveyed by these clauses. Reading is the first action to be fulfilled by the reader/user. The second action refers to keeping the manual/instructions. In fact, the manual is not only intended to instruct the reader/user but also to be used as a reference in case things do not go well. Thus, the reader/user needs to consult the manual when he faces difficulties with the product. In short, the use of coordinating conjunction to link between the two clauses that express 'reading' and 'keeping' the manual means that both actions are of equal importance. Moreover, the use of the imperative, as mentioned before, in the first clause entails that the second clause that contains 'keeping' is also in the imperative mood. Since both actions are conveyed through the imperative the reader/user has to perform both actions bearing in mind that they are of equal importance.

Yet, the manuals show a diversity of word choice in terms of making reference to the product. The words used differ from manual to another hence they are produced by different companies. The analysed manuals reveal that the word 'set' is used 3 times which makes it more frequent than the other words. Thus, apart from the word 'set', the words used to refer to the owner product including 'machine', 'appliance', 'product', 'unit' are used only once in the analysed manuals. In addition, there are cases where the name of the product is used instead. For instance consider the use of '...this heater', '...the iron', and '...this water heater' in (D), (F), and (M) respectively. Therefore, the use of the name to refer to the product, instead of using super-ordinate words as 'unit', 'product', 'machine', and 'appliance', gives the reader/user more clarity and precision about the product being described so not to confuse it with other products. Moreover, the manuals produced with the same company show a consistent use of the same super-ordinate to refer to the owner product. As a result, the word 'set', previously mentioned

as more frequent than others, is used in three of the manuals produced by the same company, LG in this case.

Given that there are two actions to be performed by the reader/user as a first request from the company before handling the product, the word choice used to express the second action is worth considering. Even though not all manuals request for the second action, that is keeping the manual, the words used in the process of conveying this action involves the use of three words. These are 'retain', 'keep', and 'save'. In this move, we can notice that their frequency of use in almost all manuals, although the words 'retain' and 'keep' are more prominent than the word 'save' which is used only once. In turn, 'retain' appears, in this move more than the word 'keep' does. In terms of frequency, 'retain' is used 5 times as opposed to 'keep' which is used 3 times. The difference between the words, though not the meaning, lies in the fact that they are used in different contexts. That is, while 'retain' is used in formal context, the word 'keep' is more likely to be used in informal one since it is a part of the everyday English. Taking this into account, we can assume that the manuals used 'retain' instead of 'keep' tend to be more formal. To support this view, the analysis revealed that in all five cases of the word 'retain' there is the use of the word 'please'.

Bearing in mind that the imperative mood is used to convey this move, the word 'please' is used to make it appear as a request to perform the intended actions which gives it more politeness. Since both actions required from the reader/user are of equal importance what applies for the first action, which is reading, applies also for the second that is keeping the manual. Thus, the word 'please' is intended for both actions namely reading and keeping the manual. It is more convenient, then, to use a polite word as 'retain' to express the action of keeping the manual. On the other hand, the

instances where the word ‘keep’ is used, expectedly, do not show any use of the word ‘please’.

5.1.2. Thanking the customer for buying the product

A	Congratulations on your purchase, and welcome to Philips!
B	Thank you for purchasing a Samsung product.
C	<i>Thank you for purchasing a LG microwave oven.</i>
D	<p style="text-align: center;">THANK YOU!</p> <p style="text-align: center;">Congratulations on your purchase and welcome to the LG family.</p>
E	CONGRATULATIONS ON CHOOSING OUR MACHINE

Figure 14. Different instances of the move ‘thanking the customer’

Although it is not used in all manuals, this move is intended to thank the customer. The above are extracts from the manuals that used this move. The first thing to be noticed in these instances is the use of the words that express gratefulness and happiness on the part of the company. Thus, the words used to achieve such intended meaning are mainly ‘thank’ and ‘congratulation’. In terms of frequency, both words show the same frequency of use. Precisely, the words ‘congratulation’ and ‘thank’ appear 3 times out of 5 instances that show the use of this move. The reason behind this is that one of the manuals, in fact, uses both words at the same time, namely the case of (D), which is not the case for the other manuals that show only one use of either words. Since they have equal frequency of use, in these instances, we can assume that they are of equal importance. In spite of that, the words, namely ‘congratulation’ and ‘thank’, are used primarily to convey the intended message of the company. This consideration leads

to consider the meaning of both words in order to know whether they share the same meaning. First, according to Longman Dictionary of Contemporary English, the word 'thank' means "to tell someone that you are pleased and grateful because of something they have done, or to be polite about it". Second, the word 'congratulation' means "when you tell someone that you are happy because they have achieved something or because something nice has happened to them". Although at the first glance both words seem very different from each other, they have something in common which is to be happy about something achieved or done. Since the word 'pleased', which is used in the definition of 'thank', implies the meaning of happiness it is more likely that both words have the same intended meaning. In other words, the manuals that show the use of 'thank' imply that the company is happy that you, as the customer, bought her product. The same thing can be said to manuals that used the word 'congratulation'. Thus, in both cases the company is happy because customers have purchased her product. So, as a way to show her gratitude and happiness she has to thank the customers by using either words namely 'congratulation' or 'thank'.

Worth pointing, knowing that the company uses such words as 'congratulation' and 'thank' to show her gratefulness and happiness means that she also shows her politeness towards the customers. Therefore, expressing politeness implies the use of appropriate words which serve so. One of the words to be associated with politeness is the use of the word 'purchase' that has the meaning of 'buy'. In the 5 instances presented above the word 'purchase' appears 4 times with one occurrence of the word 'choose'. Although it has the same meaning as 'buy', the word 'purchase' is used most of the times hence it is more polite than the word 'buy'. Thus, the word 'purchase' appears with both words 'congratulation' and 'thank' to express politeness. In addition to that, the word 'congratulation' is used with the word 'choose' instead of 'purchase' in

the case of (E). In this case, the word ‘congratulation’ does not only express the company happiness about the customer choice, but also that the customer has made the best choice in purchasing the company product. This consideration leads to satisfaction and trust on the part of the customer.

In addition to the words used to thank the customer, there is the use of the company name before super-ordinate word of the ‘product’ or the name of the product. Thus, except from the case of (E), the remaining instances mentioned above include the name of the company as in “...welcome to Philips”, “...a Samsung product”, “... LG microwave oven”, “...welcome to the LG family”. The use of the name is to remind the customer of the company name and to make him recognise the purchased product as the best one since the mentioned company produces it. For instance, in the case of (B) which is a Samsung product, the company mentioned the name ‘Samsung’ to remind the customer that the product that he has chosen and trusted is a Samsung product and not any other product. Besides, the word ‘welcome’ is to imply that the customer is now related to the company in the sense that he is more likely to buy its product in the future. For instance, consider the case of (A) and (D) namely “...welcome to Philips” and “...welcome to LG family” respectively. In the first case “...welcome to Philips” is to convey that the customer will discover Philips product through the purchased product and he is now one of the Philips clients. In the second case this assumption is expressed rather clearly through the use of the word ‘family’ which serves to establish a solid relationship between the customer and the company hence generally the family members have close relationship towards each other. In other words, it seeks to convey that the company and the customer are family since the customer chose her products. Thus, as a family member, he has to maintain this relationship through buying the company product in the future.

5.1.3. Safety information

Read and follow all instructions before using your Vacuum cleaner to prevent the risk of fire, electric shock, personal injury, or damage when using the Vacuum cleaner. This guide do not cover all possible conditions that may occur. Always contact your service agent or manufacturer about problems that you do not understand.

A  This is the safety alert symbol. This symbol alerts you to potential hazards that can kill or hurt you and others. All safety messages will follow the safety alert symbol and either the word "WARNING" or "CAUTION".

 **WARNING** This symbol will alert you to hazards or unsafe practices which could cause serious bodily harm or death.

 **CAUTION** This symbol will alert you to hazards or unsafe practices which could cause bodily injury or property damage.

 **WARNING** - To reduce the risk of fire, electric shock, or injury:



To prevent injury to the user or other people and property damage, the following instructions must be followed.

- Incorrect operation due to ignoring instruction will cause harm or damage. The seriousness is classified by the following indications.

B  **WARNING** This symbol indicates the possibility of death or serious injury.

 **CAUTION** This symbol indicates the possibility of injury or damage.

■ Meanings of symbols used in this manual are as shown below:

	Be sure not to do.
	Be sure to follow the instruction.

Explanation of symbols
Throughout this Operation Manual the following symbols are used:

C  **Important safety information**
This is the general warning sign. It is used to alert the user to potential hazards. All safety messages that follow this sign shall be obeyed to avoid possible harm.

 **Caution, risk of electric shock**

 **Caution, risk of fire**

 **Caution, hot surface**

 **Read the instructions**

 **Useful information.**
Important information or useful hints about usage.

Please take note this manual uses the following symbols to emphasize particular information:

D  **WARNING**
Identifies an instruction which, if not followed, might cause serious personal injuries including possibility of death.



 **CAUTION**
Denotes an instruction which, if not followed, may severely damage the unit and/or its components.

NOTE: Indicates supplementary information needed to fully complete an instruction.

E  The lightning flash with arrowhead symbol, within an equilateral triangle, is intended to alert the user to the presence of uninsulated "dangerous voltage" within the product's enclosure that may be of sufficient magnitude to constitute a risk of electric shock to persons.

 The exclamation point within an equilateral triangle is intended to alert the user to the presence of important operating and maintenance (servicing) instructions in the literature accompanying the appliance.

F What the icons and signs in this user manual means:

 WARNING	Hazards or unsafe practices that may result in severe personal injury or death.
 CAUTION	Hazards or unsafe practices that may result in minor personal injury or property damage.
 CAUTION	To reduce the risk of fire, explosion, electric shock, or personal injury when using your washer, follow these basic safety precautions:

We have provided many important safety messages in this manual and on your appliance. Always read and follow all safety messages.

G  This is the safety alert symbol.
This symbol alerts you to potential hazards that could eventually result in property damage or serious bodily harm, even death.

The safety alert symbol will be followed by either the word "WARNING" or "CAUTION," then an important safety message. These words mean:









 WARNING	This symbol indicates the possibility of serious bodily harm, even death.
 CAUTION	This symbol indicates the possibility of injury or damage to property.

Figure 15. Different instances of 'safety information' move

Safety information is more likely to explain the signs and symbols used in the manuals so that to provide the reader/user with the necessary information to prevent serious injuries or damage to the product. Therefore, the information provided by the safety information is for the sake of both the user and the product. To achieve this

purpose, the information supplied by the manual tends to be organised into two categories namely they are ‘warning’ and ‘caution’. In manuals, they are generally written in bold letters so as to spot them easily. In addition, a symbol or sign is used alongside the words ‘warning’ and ‘caution’ to signal the presence of safety information. Symbols and signs also serve to attract the attention of the reader/user in case he misses the words ‘warning’ and ‘caution’ if they are not written in bold letters. For instance, consider the case of (D) and (F). Most often, the sign used to indicate ‘warning’ and ‘caution’ is the exclamation mark inside a triangle (). However, some manuals use this symbol to only express ‘warning’ as it is the case for (D). Other symbols are also used to indicate additional safety information as a slashed circle () and an exclamation mark inside a circle () as in (B), flame inside a triangle (), wavy lines inside triangle () and letter ‘i’ inside a square () as in (C), and lighting flash inside a triangle () as in (E).

Regardless of the type of symbols used, they must be explained clearly to make the reader/user familiar with them before he reads through the manual. The symbols used are associated mainly with both ‘warning’ and ‘caution’. Knowing what the symbols refer to, it is very important to explain for the reader/user the meaning of ‘warning’ and ‘caution’. Even though those manuals differ in the style and sentence structure they use to explain ‘warning’ and ‘caution’, they all include such words as ‘serious injuries’, ‘damage’ and ‘death’. To put it another way, ‘serious injuries’ and even ‘death’ are generally associated with ‘warning’ whereas ‘damage’ appears generally in ‘caution’. In other words, ‘warnings’ seek, mainly, the safety of the user and ‘cautions’ the safety of the product.

In addition, the words ‘warning’ and ‘caution’ are defined using the same style and sentence structure. The main difference between the two is explained in the last part of the sentence in order to convey whether the presented information is about a ‘warning’ or a ‘caution’. For instance consider the following, “...serious bodily harm or death”, as opposed to “...bodily injury or property damage”. These two examples represent ‘warning’ and ‘caution’ respectively since the first one is more concerned with the safety of the user while the second one is mainly about the safety of the product. Moreover, some manuals prefer to use bold letter to draw the reader/user attention to notice that this piece of information is very important. For instance consider the case of (F) namely, “...*in severe personal injury or death*” versus “...*in minor personal injury or property damage*”.

Worth mentioning, the safety information shows the use of the word ‘hazard’ more frequently to express danger and risks that may face the user. It seems that there is a preference to use this word instead of using other words that convey the same meaning such as the word ‘danger’. The reason behind this lies in the fact that the word ‘hazard’ describes a very serious situation or extremely damaging while ‘danger’ describes a situation that may be not serious. As a result, the word ‘hazard’ can be described as a very specific whereas ‘danger’ as an overall situation. For instance, a dangerous accident is an overall quality of the situation hence it may include a very serious accident as car accidents or a little injury accident as cutting your finger with a knife. In addition, the word ‘hazard’ is generally associated with materials, chemical, or environment that may threaten people’s life. On the other hand, ‘danger’ is related to people, situations, and even animals. Thus, one cannot expect to hear a hazardous animal but instead a dangerous animal. In short, the word ‘hazard’ evoke alert and the word ‘danger’ is more likely related to fear.

Taking this assumption into account, the analysed instances of safety information reveal that the word ‘alert’ most of the times occurs with the word ‘hazard’. As mentioned before, the word ‘hazard’ serious situations that are extremely harmful for people, the use of the word ‘alert’ is more convenient since such harmful situations must be warned seriously in order to take the necessary measurement to avoid or prevent them from happening.

Following the Longman Dictionary (2009), the word ‘alert’ means “to officially warn someone about a problem or a danger so that they are ready to deal with it”. Therefore, the use of the word ‘alert’ implies that the company of the product is warning the reader/user of the potential danger and risks that may occur to the user or the product in case of misuse. By doing so, the company is, in fact, not liable to what might happen to the user if he is not to follow the safety information included in the manual.

Having said that, it is worth mentioning that the symbols discussed earlier are non-linguistic i.e. they are not words. However, they are still meaningful to the reader/user. Therefore in what follows more attention is given to the linguistic aspect of the safety information. To do so, a set of software is used to save time and effort. In fact, the software helps to identify the most frequent words, the nature of the words as grammatical, common, or academic, the main key words used in the presented safety information extracted from the analysed manuals.

The following table represents the main keywords that appear in the safety information of the analyse manuals.

keywords	Word frequency if the data is as large as the reference corpus	
1	alert	3214.39
2	symbol	2061.43
3	hazard	1757.42
4	caution	1001.42
5	manual	571.94
6	injure	528.94
7	instruct	401.07
8	harm	365.27
9	warn	320.22
10	damage	298.75
11	safe	203.02
12	shock	194.81
13	message	169.44
14	risk	166.28
15	death	162.05
16	indicate	159.15
17	property	137.75
18	follow	134.24
19	potential	105.06
20	serious	96.27
21	electric	81.12
22	practise	76.42
23	cause	58.78
24	body	51.19
25	sign	43.23
26	possible	39.74
27	result	39.29
28	inform	38.09
29	operate	36.45
30	important	29.92
31	fire	29.82
32	person	28.75

Table 6. Keywords in safety information extracted from user manuals

Although the table shows the main keywords in safety information of the analysed manuals, the frequency of each word does not show the real occurrences of the word in the original text which is safety information. It rather gives the frequency of the words if the text is to be as large as the reference corpus which contains 100 million words. However, the words appear in the table are ordered according to their frequency in the text of safety information. Thus, for instance, the ‘alert’ is on the top of the keywords is more frequent in the text of safety information. If the text is as large as the

reference corpus its frequency would be 3214.39 times. Thus, by comparing the frequency of the word in the text of safety information and the reference corpus, which involves 100 million words, the software is to decide whether this word is to be listed in the keywords or not.

Since the word 'alert' is most frequent, according to the software results, it has a significant role in conveying the safety information. Apart from "officially warn" the user, the use of such a word catch the reader/user attention while reading safety information. That is, when encountering the word 'alert' the reader/user is more likely to expect that something very important is to be mentioned and thus, he will give more attention to the coming information. As a result, he will possibly be 'on the alert' to know more. Once he knows the needed safety information he is certainly to stay vigilant for a possible danger while operating the machine at hand.

As shown by the table, the word 'symbol' is the second more frequent key word. Knowing that safety information involves the use of symbols so that to facilitate the task of the reader/user in tracking the safety information throughout the manual, the explanation of such symbols is very important because without which the reader/user cannot understand what the symbols stand for. So, the word 'symbol' occurs to explain the meaning of the pictogram intended to convey safety information. For instance consider the use of the word 'symbol' in the following: "this symbol indicates...", "this symbol alerts...", "the following symbols..." as in the case of (G), and (D) respectively. Since symbols (or pictograms), are used next to the explanation, there is the use of demonstrative pronoun 'this' to refer to the pictograms hence the use of 'this' implies that the object being described is very close. To make the image clear, pictograms are small pictures used to illustrate the meaning of the concept or idea being described. The

pictures used in pictogram resemble to what they signify. For instance, the use of lighting flash inside a triangle () indicates the danger of electrical shock.

Not surprising, the word 'hazard' is one of the keywords that appears in the results of the analysis. Though the difference between 'hazard' and 'danger' is already discussed, the word is very important to make the user aware of the possible danger that may threaten his life as well as the product at hand. Although the word 'hazard' does not successively appear after the word 'alert' in terms of its frequency, it still appears in the top of the most frequent keywords. Thus, while the word 'alert' is used to warn him about the possible danger, the word 'hazard' conveys to him the degree of danger so not to take things lightly.

In addition, the word 'caution' is also recognised as one of the most frequent keywords in the safety information. In terms of frequency, it comes right after the word 'hazard'. The use of such word has a significant effect on the reader/user. It helps him to identify the information concerned with safety. Thus, seeing the word 'caution' makes him understand clearly that this piece of information is more likely about his safety or the product safety. Accordingly, the word 'caution' shares the role of conveying safety information to the reader/user with the previously mentioned words namely 'alert', 'symbol' and 'hazard'. At first, these words do not seem to have something in common hence they have different meanings. However, considering their significant role in expressing safety to the reader/user, they appear as interrelated words in the sense that they share the same intended meaning. Therefore, trying to understand their interrelationship, it is more useful to consider them as: 'alert' is expressed through 'symbols' that contain 'hazardous' situation for which the reader/user has to take 'caution'.

Even though the keywords represented by table (10) are extracted from the safety information of the analysed manuals, there are some keywords that do not have close relation to safety. To make it clear, consider, for instance, the words ‘manual’ and ‘instruct’. In fact, the two words are related to each other in the sense that the word ‘instruct’ is to be expected to occur in manuals. In return, the word ‘manual’ makes us expect the word ‘instructions’. Thus, the presence of one is more likely to evoke the presence of the other. In spite of that, the two words are not likely to stimulate ‘safety’. On the other hand, words such as ‘injure’, ‘harm’, ‘warn’ and ‘damage’ are much related not only to each other but also to the notion of safety. That is, the presence of these words triggers the notion of safety in the mind of the reader/user. The words are interrelated in the sense that the meaning of the word ‘damage’ includes both ‘injure’ and ‘harm’; in like manner, the meaning of the word ‘harm’ includes both ‘injure’ and ‘damage’. With that being said, the keywords shown by the table give a much better understanding of the words used mainly to convey the notion of safety. The degree of their closeness to ‘safety’ depends on how much they trigger the notion of safety. Taking this assumption into account, the reader/user is to expect the occurrence of such words in safety information hence they are the most relevant ones to convey the notion of safety. Thus, the ten first words in the table, apart from ‘manual’ and ‘instruct’, are directly related to the safety, be it the safety of the user or even the product. In fact, they strongly convey the intended meaning of the safety information. However, it does not mean that the remaining words are not related to safety, they are rather less related in comparison to the first words on the top of the table. For more clarity about the assumption of words closeness to the notion of safety, the following diagram will illustrate the point of how much the keywords presented in the table are close to the notion of safety.

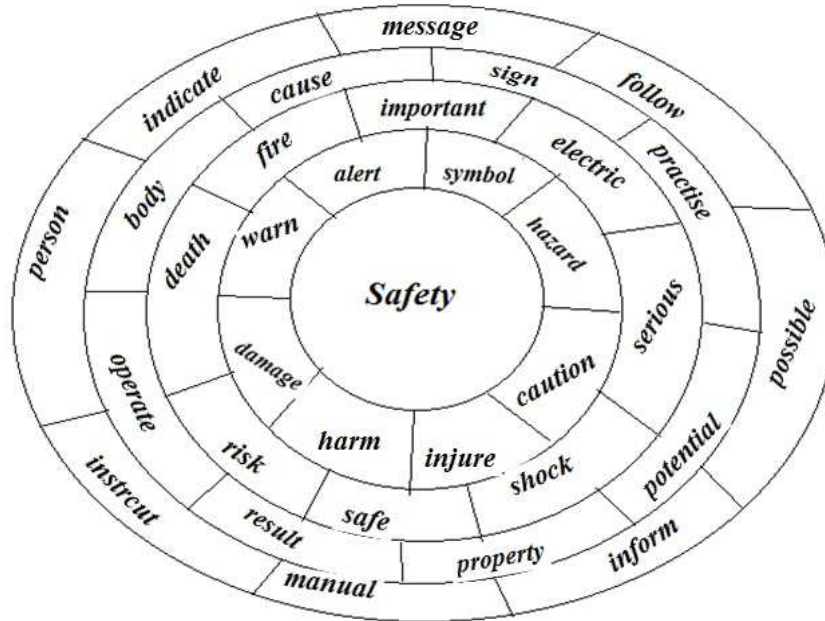

Figure 16. Words closeness and relationship to the notion of safety

The diagram is an attempt to explain how the keywords, revealed from the analysis of safety information, are related to the notion of safety. Regardless of their frequency, the keywords shown in the diagram are to communicate safety information to the reader/user. However, they differ in their degree of relevance to the notion of safety. Thus, the more they are close and relevant the better they convey the meaning of safety. That is, the keywords that appear in the diagram surrounding the word ‘safety’, they are the more likely to stimulate the notion of safety to the reader/user. On the other hand, the far the circle is in the diagram the more likely the keywords to be less close and relevant to the notion of safety i.e. they do not trigger the notion of the safety in the mind of the reader/user. In addition to that, the use of these words is to ensure the safety of the user since they have such meaning as damage, injuries, hazard, harm and so on. Therefore, knowing that something is dangerous and harmful makes the reader/user more likely to avoid it at all costs and this will ensure his safety. In other words, using such words is to raise the user awareness of the danger in order to make him be on the alert while operating the product.

4.1.4. Safety instructions

In fact, safety instructions are, generally, made up of warnings and cautions. An introductory sentence is used to make the reader/user aware of the importance of the instructions. Thus, it states the purpose of reading the instructions. For instance consider *“to reduce the risk of fire, electric shock, or injury to persons when using the appliance, follow the basic precautions...”*. In this sentence, the purpose is given right at the beginning since it is the most important piece of information. The next part of the sentence gives the reader/user what to do. Knowing this, more light is shed on the first introductory sentence of safety instructions. Therefore, the following are the main sentences used in the analysed manuals so that to introduce safety instructions:

1. To reduce the risk of fire, electric shock, or injury.
2. To prevent injury to the user or other people and property damage, the following instructions must be followed.
3. To reduce the risk of fire, electric shock, or injury to persons when using your appliance, follow basic precautions including the following.
4. To reduce the risk of fire, electric shock, or injury to persons observe the following.
5. To avoid any risk of personal injury, material damage or incorrect use of the appliance, be sure to observe the following safety precautions.
6. If the information in these instructions is not followed exactly, a fire or explosion may result causing property damage, personal injury or death.
7. Throughout this manual, you’ll see Warning and Caution notes. These warnings, cautions, and the important safety instructions that follow do not cover all possible conditions and situations that may occur.
8. To reduce fire or shock hazard, do not expose the unit to rain or moisture.

9. To reduce the risk of burns, electric shock, fire, injury to persons, or exposure to excessive microwave energy.
10. To reduce the risk of fire, electric shock, or injury to persons when using this appliance, follow basic precautions, including the following.
11. To reduce the risk of burns, fire, electric shock, or injury to persons.
12. When using electrical appliances, basic precautions should always be taken to avoid the risk of fire, electric shock and personal injury, including the following.

The above represent the introductory sentences extracted from safety instructions of user manuals of household equipments. Except for some manuals, they show a constant use of infinitive phrase ‘to’ at the beginning of the sentence in order to express the purpose of the instructions. In fact, the infinitive phrases, shown above, function as adverbial for the verb in the main clause. That is, they modify the verb of the main clause. In such sentences, the infinitive phrases are used mainly to explain the purpose or ‘why’ of the sentence. Since the infinitive phrase is used first, a comma from the main clause separates it. In addition, using such a phrase at the beginning means that it is of great importance. In other words, the reader/user is given first the important information that explains why he has to do so.

In terms of frequency, there are nine instances, from twelve, that use the infinitive phrase to state the purpose of the sentence. Furthermore, the word that comes directly after ‘to’ is most of the times the word ‘reduce’. There are only two cases that do not show the presence of the word ‘reduce’ after ‘to’, they instead show the use of ‘prevent’ and ‘avoid’ which are used in (2) and (5) respectively. More precisely, the word ‘reduce’ co-occurs directly with the word ‘to’ in seven instances out of nine that show the use of infinitive phrase. The two remaining instances, out of nine, reveal one occurrence for the words ‘prevent’ and ‘avoid’. Following this, the reader/user is likely

to expect what “to reduce, prevent, or avoid” as he reads the first two words. To provide such information to the reader/user, the sentences show that there is the use of ‘the risk of fire’ pattern after the phrase ‘to reduce’. Thus, in the seven occurrences of the phrase ‘to reduce’ there are four co-occurrences of the pattern ‘the risk of fire’. There are also other patterns used after ‘to reduce’ namely ‘the risk of burns’ and ‘fire or shock hazard’ which show two occurrences and one occurrence respectively. In addition, the infinitive phrases that use ‘to prevent’ and ‘to avoid’ show diversity of words; that is, they do not follow the same pattern as ‘to reduce’. As a result, the words that appear after them are “injury to the user or other people” and “any risk of personal injury” respectively.

Shifting attention to the next phrase that comes after ‘the risk of fire’, thought it is the frequent one, it seems that ‘to reduce’ phrase shows the same pattern of words which is “electric shock, or injury to persons”. To make the image clear, the seven instances of the infinitive phrase ‘to reduce’ include six occurrences of the phrase pattern early mentioned, even though ‘to persons’ is not used in (1). Bearing this in mind, it is more convenient to consider that the infinitive phrase that starts with ‘to reduce’ is more likely to follow the same pattern of words unlike the other instances of the infinitive phrases that include ‘to prevent’ and ‘to avoid’. Thus, to have a much better understanding of the nature of the introductory phrase used in safety instructions, the sentence is divided into two parts, which in fact, represent the dependent clause and the main clause. First, the dependent clause is considered more particularly hence it is placed at the beginning of the sentence. Accordingly, the following table show the nature of the first part of the introductory sentence namely the dependent clause and gives the frequency of use in the twelve manuals that show the use of such a sentence.

First part in the Introductory sentence of safety instructions	Frequency of each part in 12 manuals that show the use of the introductory sentence
Infinitive phrase	9
Adverbial phrase	2
Conditional phrase	1

Table 7. Nature and frequency of the first part of the introductory sentence.

As stated in the table (7), the first part of the introductory sentence seems to have three types of phrases namely, infinitive, adverbial, and conditional phrases. Obviously, the most frequent one is the infinitive phrase with nine occurrences in the twelve manuals. On the other hand, adverbial phrase and conditional phrase tend to be less used as the first part of the introductory sentence as they occur only twice and once respectively. Therefore, we can distinguish two main reasons for the occurrence of the infinitive phrase at the beginning of the sentence. First, it is the most frequent phrase type in the analysed manuals and, second, it conveys very important piece of information to the reader/user because, generally, such type of phrases express the purpose of the sentence.

With that being said, the following table shows the analysis of the infinitive phrase used in the twelve manuals. The infinitive phrase, as the first part of the introductory sentence, is divided into sub-parts with a view to emphasize the nature and the use of such a phrase. In turn, each sub-part is represented by a pattern which shows the group of words used in each sub-part. In addition, the table provides the frequency of use in both sub-parts and patterns used in the infinitive phrase in the twelve manuals.

Infinitive phrase at the beginning	Frequency of each pattern in the nine instances
Sub-part 1	9
a. To reduce	7
b. To prevent	1
c. To avoid	1
Sub-part 2	9
a. The risk of fire	4
b. Fire or shock hazard	1
c. The risk of burns	2
d. Injury to the user	1
e. Any risk of personal injury	1
Sub-part 3	8
a. Electric shock or injury	1
b. Electric shock or injury to persons	5
c. Other people and property damage	1
d. Material damage or incorrect use of the appliance	1

Table 8. The infinitive phrase patterns frequency.

Clearly, the infinitive phrase, used as the first part of the introductory sentence, is divided into three sub-parts which in turn are divided into patterns. However, the nine instances of the infinitive phrase show that ‘sub-part 3’ is not used in all the instances. The use of this ‘sub-part’ appears only in eight instances of the total nine. This means that one of the instances does not include ‘sub-part3. On the other hand, the other sub-parts namely 1 and 2 tend to be used in all the nine instances of the infinitive phrase. Taking into consideration the frequency of use in the different sub-parts, it seems that the infinitive phrase is more likely to be divided into three sub-parts. Moreover, the sub-parts show a diversity of patterns with a different frequency of use. In spite of their variety, there is a more frequent pattern in each sub-part. On the basis of their frequency, each sub-part has a preferred pattern to be used in the infinitive phrase. To make it clear, the most frequent patterns in each sub-part are namely ‘to reduce’ in sub-part1, ‘the risk of fire’ in sub-part2, and ‘electric shock or injury to persons’ in sub-part3. In terms of frequency, they show seven, four, and five occurrences respectively. The remaining patterns show only one occurrence for each pattern with the exception of

pattern (c) in sub-part2 where there are two occurrences of the same pattern. So -a preferred model of the infinitive phrase, that is to be used as the first part of the introductory sentence of the safety instructions, can be created by combining the most frequent patterns in the three sub-parts. That is, sub-part1/pattern (a) + sub-part2/pattern (a) + sub-part3/pattern (b). More precisely, to reduce + the risk of fire + electric shock or injury to persons.

The resulting phrase is as the following:

M 1: To reduce the risk of fire, electric shock, or injury to persons

Therefore, this model is more likely to be used in the first part of the introductory sentence of the safety instructions. In addition, this also means that the model, created from the combination of the most frequent patterns of the infinitive phrase, will be a more frequent one than other possible models. Thus, consider the following using the pattern (c) from the sub-part2 which has two occurrences making it second frequent pattern in sub-part2. The phrase model would be as:

M 2: To reduce the risk of burns, electric shock, or injury to persons

Keeping in mind that this model is made up through only the change of the sub-part2, the resulting phrase is not completely different in terms of meaning. That is, considering the resulting phrase closely, the difference is at the level of the word 'burns' instead of the word 'fire' which is used in the first model of the infinitive phrase. Therefore, the words are close in meaning in the sense that 'fire' is more general than the word 'burns' which convey a specific meaning. In other words, 'fire' indicates flames and damage while 'burns' indicates injuries caused by fire. Other models of the infinitive phrase can be retrieved from the following, though not all the possible models occur in the

instances of the twelve manuals that show the use of the introductory sentence in the safety instructions.

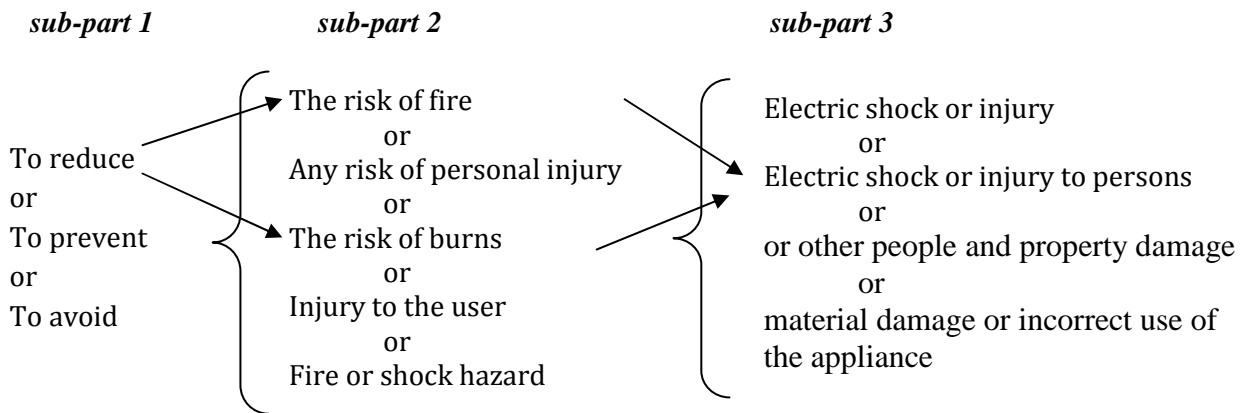

Figure 17. Possible models using infinitive phrase in safety instructions.

Although the above figure shows a possibility of many models to be used as the infinitive phrase of the introductory sentence, there are only two prominent models used to represent such a phrase. The models are indicated by the arrows in the diagram. The models are already mentioned above as (M1) and (M2). In terms of frequency, M1 shows more prominence of use since it is used three times, as opposed to M2 which is used only twice. Since the infinitive phrase is the first part of the sentence, it means that the second part is the main clause. In fact, the infinitive phrase can function as nouns, adjectives, or adverbs. When it is used at the beginning of the sentence, it is more likely to function as an adverb which modifies the verb of the main clause. Thus, to gain a better understanding of the introductory sentence used in the safety instructions, the second part of the sentence that represents the main clause is considered next in the analysis.

To start with, it is worth mentioning that the twelve examples of the introductory sentence of the safety instructions include nine instances that use the infinitive phrase.

In turn, the nine instances show only five appearances of the main clause i.e. the second part of the sentence. In other words, not all the sentences, which represent the nine instances of the infinitive phrase, have the main clause. Thus, there are six cases that include the use of infinitive phrase and the main clause and three cases where there is no use of the main clause i.e. there is only the infinitive phrase. The remaining instances involve diversity of sentences namely conditional and adverbial.

Knowing that the infinitive phrase functions mainly as adverbial, the main clause, expectedly, starts with a verb in the imperative mood. In addition, the main clause is expressed in the active voice except for one case which shows the use of the imperative in the passive voice. The most frequent verbs used in analysed instances are the verb ‘follow’ and ‘observe’. In fact, ‘follow’ is used three times including an instance that shows the verb at the passive voice. On the other hand, the verb ‘observe’ is used twice including one instance showing the verb in the infinitive form. For a much better understanding, consider the following table.

Verbs	frequency	Tense and mood	Detailed frequency		
Follow	3	Imperative	2	Imperative	5
		Imperative passive voice	1		
Observe	2	Imperative	1	Infinitive	1
		Infinitive	1		
Expose	1	Negative imperative	1		

Table 9. Verbs and tense used in safety instructions introductory sentence

The table shows that three main verbs are used in the main clause of the introductory sentence of safety instructions, namely ‘follow’, ‘observe’ and ‘expose’. Regardless of their tense and mood, they show a frequency of three, two, and one respectively. In addition, the last column of the table shows the frequency of the verbs taking into consideration the tense and mood. That is, the verb ‘follow’ is used three

times including two instances of the imperative in the active voice and one in the passive voice. The same thing can be said about the verb ‘observe’ that shows two occurrences, one in the imperative and the other one is in the infinitive form. Unlike, ‘follow’ and ‘observe’, the verb ‘expose’ is only used once in the imperative, namely the negative one. Therefore, the most frequent mood is the imperative hence it is used in five instances as opposed to the infinitive that is used only once.

Taking into account that safety instructions include more than the introductory sentence -discussed earlier, it is primarily concerned with instructions that ensure the safety of the user and the product as well. Therefore, in what follows, the analysis is much concerned with the features of the safety instructions used in the user manuals. To start with, the vocabulary used in the safety instructions is analysed so that to have a better understanding of word choice. The following represents analysis of the safety instructions using vocabulary profile software. The latter includes the analysis of vocabulary in terms of the common words used in English namely, 2000 words and also provides an analysis of academic words.

	<u>Families</u>	<u>Types</u>	<u>Tokens</u>	<u>Percent</u>
K1 Words (1-1000):	403	574	5688	70.86%
Function:	(3545)	(44.16%)
Content:	(2143)	(26.70%)
> Anglo-Sax	(868)	(10.81%)
=Not Greco-Lat/Fr Cog:		
K2 Words (1001-2000):	180	245	866	10.79%
> Anglo-Sax:	(317)	(3.95%)
1k+2k		(81.65%)
AWL Words (academic):	108	156	382	4.76%
> Anglo-Sax:	(17)	(0.21%)
Off-List Words:	<u>?</u>	<u>347</u>	<u>1091</u>	<u>13.59%</u>
	691+?	1322	8027	100%

Table 10. Vocabulary profile of safety instructions in 15 user manuals

The above table (10) shows the results provided by the software of vocabulary profiler. It provides the number of words in terms of families, types and tokens. In addition, it gives the percentage of each category of words. That is, function, content and academic words as they appear in the safety instructions. The software sorts the analysed words into four headings, namely K1, K2, AWL words and Off-List Words. These are meant to represent the first and second range of 2000 common words that is labelled as K1 and K2 respectively. Moreover, AWL Words are intended to show the academic words used in the text, that is safety instructions, from a list of 570 academic words. However, if the words used in the text appear neither in 2000 words nor in the AWL words, they are classified as Off-list words. Therefore, Off- List words are more likely to include the technical words used in the text hence they are not recognized as common English words, that include 2000, or as academic words; the percentage of each category is shown in bold in the table.

Thus, the results show that safety instructions of user manuals use 81.65% words of the 2000 words common in English. More specifically, 70.85% of the words are from the K1 (1-1000) and 10.79% from K2 (1001-2000). In addition, the K1 words include the use of function and content words. In other words, 70.86% of the K1 words contain 44.16% of function words and 26.70% of content words. On the other hand, academic words represent 4.76% of the words used in safety instructions. Considering that the Off-list words are to represent technical words, the safety instructions devote 13.59% to the use of technical words. In short, safety instructions of the analysed user manuals are mainly made up of 81.65% of common words in English, 4.76% of academic words and 13.59% technical words.

The safety instructions, in the user manuals, are also analysed in terms of sentence types that convey the instructions according to the mood and voice of the sentences. By doing so, it is possible to identify the most frequent sentence type in the sample and hence in the fifteen user manuals. For more details, consider the following table.

Manuals	Sentences	Sentence type	Detailed frequency	Frequency
1	27	Imperative	Ng :9Imp :4	13
		Declarative	14	14
		Conditional		
2	18	Imperative	Ng :6Imp :9	15
		Declarative	2	2
		Conditional	1	1
3	10	Imperative	Ng :4Imp :1 Nvr :3	8
		Declarative	2	2
		Conditional		
4	14	Imperative	Ng :1Imp :8Nvr :1	10
		Declarative	4	4
		Conditional		
5	10	Imperative	Ng :5Imp :3 Nvr :2	10
		Declarative		
		Conditional		
6	15	Imperative	Imp : 10 Nvr :2	12
		Declarative	2	2
		Conditional	1	1
7	16	Imperative	Ng :4Imp :5 Nvr :2	11
		Declarative	4	4
		Conditional	1	1
8	21	Imperative	Ng :9Imp :1	10
		Declarative	9	9
		Conditional	2	2
9	19	Imperative	Ng :5Imp :3	8
		Declarative	9	9
		Conditional	2	2
10	15	Imperative	Ng :5Imp :5	10
		Declarative	4	4
		Conditional	1	1
11	11	Imperative	Ng :6Imp :4	10
		Declarative		
		Conditional	1	1
12	18	Imperative	Ng :9Imp :3	12
		Declarative	5	5
		Conditional	1	1
13	18	Imperative	Ng :11Imp :2	13
		Declarative	5	5
		Conditional		
14	16	Imperative	Ng :4Imp :7 Nvr :3	14

		Declarative Conditional	2	2
15	19	Imperative Declarative Conditional	Ng :4Imp :5 Nvr :2 5 3	11 5 3

Table 11. Sentence types of safety instructions in user manuals

After analysing the safety instructions from each manual, the results show that there are three main types of sentences used to convey safety instructions. These are imperative, declarative and conditional. As shown in the table above, each sample shows a diversity of sentences used to convey the instructions. The number of sentences used in each set of the instructions varies from minimum of ten sentences to maximum of twenty-seven. Therefore, in the case of ten sentences, each set of instructions is expressed by one sentence and in the case of twenty-seven each set is conveyed by more than one sentence.

In addition, the table presents a detailed frequency that includes sub-types particularly in the case of the imperative, which entails the use of negative imperative referred to as ‘Ng’ and ‘Nvr’ for ‘never’. Thus, using such type of the imperative is meant to convey safety instructions clearly to the reader/user. Negative imperative, in fact, helps to prevent unwanted actions that may injure the user or damage the product. However, the user needs also to know what to do to prevent serious damage or injuries. To do so, the instructions include the use of the imperative that conveys to the reader/user the needed actions that he has to perform for his safety. Simply put, the safety instructions do not include only what the user has to avoid but also what he has to do. Therefore, the “dos and don’ts” of the instructions are conveyed by the use of the imperative and the negative imperative respectively. Bearing this in mind, the analysed safety instructions reveal that there is a use of declarative and conditional sentences along with the imperative. Although the conditional sentences are less used, the

prominent sentence types are those of imperative and declarative. To make the image clear, the following table provides the frequency of each type of sentences.

Sentence types	Frequency in the analysed instructions
Imperative	167
Declarative	67
Conditional	13

Table 12. Sentence types frequency

On the one hand, the table shows that the most frequent sentence type in the analysed instructions is the imperative one. The imperative sentence appears 167 times in the instructions. Although declarative sentences are not as frequent as imperatives, they show a significant presence in the safety instructions since they are used 67 times in the analysed instructions. On the other hand, conditional sentences are barely used in the analysed safety instructions. Their use in the instructions is restricted to only thirteen occurrences that make them the less used sentence type in the safety instructions.

It can also be noticed that safety instructions entail also the use of negative imperative, which is conveyed mainly by ‘do not’ and ‘never’. As mentioned earlier, the negative imperative is used to express the “don’ts” of the instructions i.e. the actions to avoid so that to ensure the safety of the user and the product. Although the negative form for the imperative is generally the use of ‘do not’, the instructions reveal that there is another word used to express negative imperative. That is, in some cases the instructions show the use of ‘never’ instead of ‘do not’, though both words carry on the meaning of negation. Accordingly, the following table provides the frequency of use for each type of imperative including negation namely through the use of ‘do not’ and ‘never’.

Imperative types	Frequency
Imperative	71
Negative imperative using 'do not'	82
Negative imperative using 'never'	14
Total	167

Table 13. Frequency of imperative including negative imperative

Here, Table 13 provides detailed information about the 167 occurrences of the imperatives in the analysed safety instructions. The identified instances of the imperatives include also the negative imperative, which uses 'do not' and 'never'. Therefore, from 167 occurrences in the safety instructions, only 71 instances refer to the use of the imperative as such. Although the remaining instances are also regarded as imperative, they appear in a negative form. More specifically, there are 82 uses of the negative imperative expressed by 'do not' and 14 uses expressed by 'never'. Taking this into consideration, the negative imperative shows more prominence of use than the imperative. Thus, both types of negative imperatives 'do not' and 'never' show a frequency of 96 occurrences in comparison to the imperative that is represented by 71 occurrences in the safety instructions.

In sum, we can say that the use of the negative imperative is more frequent in the safety instructions of user manuals because of the nature of the instructions. Seeking safety to the user and the product, this type of instructions is primary meant to prevent serious accidents that may cause injuries or damage to the product. The use of the negative imperative is justified by the purpose of preventing such dangerous accidents. The direct and more appropriate way to make the user aware of the dangerous situations or actions that he may accidentally get involved in is through the use of negative imperative. In addition, the use of 'do not' and 'never' varies according to the action to be prevented. Although, both expressions convey the negative imperative, they differ in the degree of negation. On one hand, the use of 'never' to express negation is stronger

than the use of 'do not' in the sense that 'never' signals that the actions are extremely dangerous and hence should be avoided. Moreover, using 'never' implies that the user has no choice but to avoid such dangerous actions. On the other hand, the use of 'do not' is to prevent the user from taking inappropriate actions, though he has alternative choices. That is, the use of 'do not' is to guide the user so not to make actions that may lead to abusing the product or injuries while operating the product at hand.

5.1.5. Product features and description

This move is primary concerned with the presentation of the product to the user. Thus, it includes a full description of the product in terms of overview and its different features and options. The purpose is to make the user more familiar with the product before he goes to the operation and avoid using it for different purposes except those defined by the manual. In addition, knowing the different features presented by the product help the user to determine whether the product meets his needs. This implies that the user can know for sure that the product was a good choice or not.

In order to convey such information to the user, the move shows the use of the verbal-visual rhetorical function. Unlike the early discussed moves, this one is not expressed in a purely linguistics fashion, but it includes the use of visuals. Using the visuals is a very efficient technique to make the user have a much better understanding of the product. Moreover, visuals can communicate more than the usual texts. That is, the information presented by the visuals is clear and easy to understand; it saves the user time and effort that he usually spends on reading the text that may add to his confusion. Within these terms, the move is discussed in order to determine the rhetorical function of verbal-visual relationships. The discussion also entails the nature of the text accompanying the visuals and the type of information it provides to the reader. The data retrieved from the fifteen manuals shows that not all the manuals use this move; two

manuals do not use this move at all. Hence, the analysis concerns only twelve manuals that show the use of such move.

To start with, the titles used to express this move are considered first since they are a part of the verbal-visual relationships. The analysis sheds light on the structure and word choice involved in the constructions of such titles. Thus, the following figure shows the main titles used to represent ‘product features and description’. It is worth mentioning that, in the on-going discussion we will use the letters associated with the titles as shown below.

<i>a</i>	PARTS AND FEATURES
<i>b</i>	Product Introduction
<i>c</i>	1 Your Dryer Overview
<i>d</i>	.SERVICE PARTS
<i>e</i>	FEATURES OF THIS TV
<i>f</i>	<u>OVERVIEW OF THE WASHING MACHINE</u>
<i>g</i>	VIEW OF YOUR REFRIGERATOR / FREEZER
<i>h</i>	Replacement Parts.
<i>i</i>	PARTS AND FEATURES
<i>j</i>	UNDERSTANDING YOUR MICROWAVE OVEN
<i>k</i>	KNOWING YOUR SEWING MACHINE
<i>l</i>	<u>DESCRIPTION OF THE APPLIANCE</u>
<i>m</i>	Parts and controls

Figure 18. Different instances of ‘product features’ move

The analysed manuals manifest a diversity of titles used to label the information that conveys description and features of the product. It seems that nouns are the main constituents that make up the titles. The number of words used varies from title to another. The longest one among the analysed title includes five words as it is the case for (f) and (g). Successively, in terms of number of words, (j) and (k) show the use of four words in the construction of the title. Furthermore, the titles can be constructed using a less number of words as three and even two words. Such an assumption is best illustrated in the case of (a) and (b) that show the use of three and two words respectively. To be more precise, the titles are classified according to the number of words included in their constructions. Thus, the titles, shown in the figure, can be constructed by a minimum number of two words or a maximum number of five words. Adding more clarity, there are two cases with the use of five words, four cases with four words, four instances with three words and three instances include the use of two words.

Moreover, the titles use words such as 'and' 'for' and 'your' in their constructions. The words represent different word categories. That is, 'and' and 'for' are coordinating conjunctions whereas 'your' is a possessive determiner. These three words are used along with nouns to construct the analysed titles. Therefore, except from titles that include two words, these words, namely 'and', 'for', 'your', appear in the titles that are made up with three or more words. For instance consider the case of (a), (i) and (m). These instances are made up of three words including 'and' which is used to join, in this case, two words. The words joined by 'and' are nouns, namely 'parts', 'feature' and 'controls'. In addition, the word 'of' is used also to join nouns as in the case of (e), (g) and (l). On the other hand, 'your' is used to indicate possession. Thus, the noun that comes after is generally the name of the product. This assumption is best illustrated in the instances of (g) (j) (k) as they mention the name of the product namely refrigerator,

microwave and sewing machine respectively. To make the image crystal clear, the models that are used to construct the analysed titles are as the following.

Noun + noun

Noun + and + noun

Noun + of + noun

Noun + your + noun

The models reveal that titles are mainly made up of nouns with the inclusion of such words as ‘and’, ‘of’ and ‘your’. Knowing that, the number of words in titles constructions seems to decrease without the use of such words. In other words, titles that do not include these words are likely to be made up of only two words, which is the minimum number. Furthermore, titles that use such words tend to use more than two words in the title construction. More precisely, the word ‘and’ is used in titles that only have three words, while ‘for’ and ‘your’ are used in titles that include more than three words (four or five words). In terms of frequency, the word ‘and’ is used three times which implies that there are three cases in which titles have only three words. On the other hand, the word ‘your’ is used three times as opposed to the word ‘of’ which is used four times making it the most prominent word of the three. Reasonably, the word ‘of’ is mostly used in nominal sentences particularly those that include many words. Such construction is used to communicate the meaning of the sentence without using the usual sentence constructions that is subject, verb and complement. Moreover, it helps to convey the intended meaning with the use of few words. The use of nominalisation helps to produce sentences with a few words. However, the use of such constructions may confuse the reader if it is not well made. That is, using only nouns means that there is no subject, verb, and complement that add usually to the

understanding of the reader. Thus, getting rid of these words is more likely to confuse the reader especially if there are too many nouns, which may lead to awkward constructions that result in ambiguity.

Although the titles used in this move differ from one manual to another, they have the same purpose that is introducing the product to the user. The rhetoric of visual is used to achieve such a purpose hence introducing the product entails to make the user familiar with the different parts included in it. That is, the user has to know the name of the different parts and their function vis-à-vis the product. This step is very important because it helps the user to understand the operating instructions; since he is familiar with the names of the different parts, he can know which part is referred to in the instructions. For instance, consider these names of parts ‘body release’ and ‘wand’. If the user is to operate the product, in this case vacuum cleaner, and he is not already aware of these parts, which are explained in the product description move, he cannot understand what these names refer to. Thus, to make sure that he understands exactly what are the parts being referred to in the instructions, the move provides the names of the different parts of the product alongside its visual that shows exactly where the parts are located in the product. Therefore, apart from the shape and design of the product, the visual that represents the product includes the labels of the different parts of the product at hand. To make the image clear, consider figure (14) that shows the use of visuals in the move of ‘product features and description’.

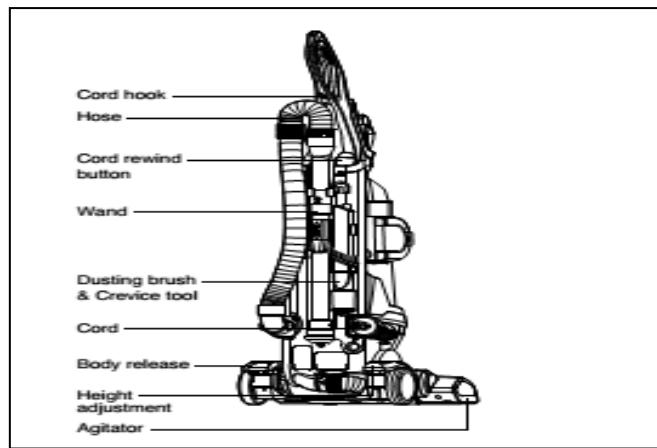

Figure 19. Visual of vacuum cleaner.

The above figure (19) represents the rhetorical function of verbal-visual relationships. It shows clearly the verbal, which is represented by the names of the different parts of the vacuum cleaner and the visual represented by the drawing showing its design and shape. Moreover, the figure shows that verbal and visual are, in fact, combined together to reduce ambiguity on the part of the reader/user. That is, the use of arrows to indicate exactly the name of each part is to give more clarity to the picture and make the reader/user locate the parts more quickly and easily. However, this kind of technique is not always used in manuals. Thus, the different parts of the product can be mentioned separately from the visual in a list indicated by numbers. The following will illustrate the point.

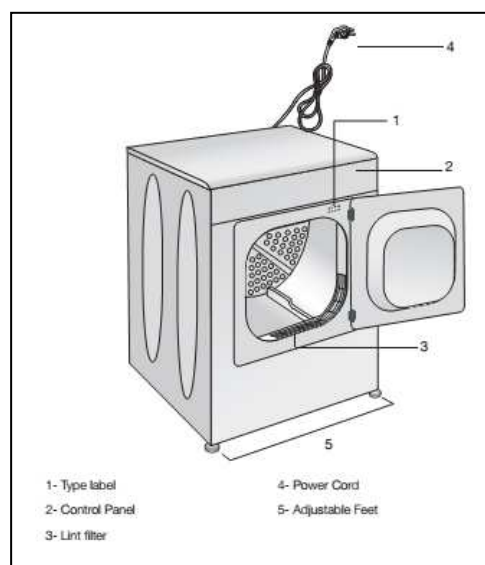

Figure 20. Names of parts separate from visual

The above figure (20) is an extract from the user manual of tumble dryer and shows that the names of the different parts of the dryer appear as a list under the visual of the dryer. The names are listed using numbers. Consequently, in order to locate the parts of the dryer, the reader/user has to consider first the list that includes the names of the different parts then he has to look at the visual to know which parts they represent. Since they are separate from each other, the reader/user is simultaneously involved in two actions; namely reading the list and looking at the visual. Not only time and effort consuming, this technique is more likely to distract and confuse the reader/user as he tries to associate the names with the parts shown in the visual. Worse is that using this technique necessitates space i.e. it takes more space than the one shown in figure (19). In user manuals, space means more pages to print and this is the least thing a company wants since it increases its expenses. Unlike figure (20), the information provided by figure (19) is easier and less confusing. In figure (19), the reader/user is doing both actions at the same time. In other words, while he is looking at the visual he is also reading the names of the different parts that are indicated by the arrows. With that being said, the technique used in figure (19) is more efficient than the one used in figure (20).

In order to distinguish which technique is mostly used, both techniques are analysed further in the manuals. For easy reference, the techniques are labelled as 'VV' and 'V+V' that stand for verbal-visual, as in the case of figure (19), and visual plus verbal as in the case of figure (20). Taking this into consideration, the manuals show that the 'VV technique' is mostly used in ten manuals to convey the move that entails features and product description. Considering its frequency, the 'VV technique' seems to be more preferred by most manuals than the 'V+V technique'.

5.1.6. Installation instructions

This move is primarily concerned with the installation of the product before its use. It includes choosing the appropriate location for the product and the assembly of the product if it comes with different accessories. Thus, the location of the product is of great importance for a good performance. Installing the product in inappropriate place that contains heat or dust may damage the product or lead to a poor performance. So, to avoid such results, the user is provided with the necessary steps that guide him for an appropriate installation of product. To do so, the move makes use of rhetorical functions including verbal-visual similarly to the move of product features and description.

In what follows, the move is considered in terms of titles used to signal this move and sentence structure used to convey the different instructions included in the move. The following represents the titles retrieved from the user manuals that show the use of this move, though not all of them include the move of installation depending on the nature of the product.

1. Assembly
2. Installation
3. Prepare the hood
4. Preparation
5. Preparing the refrigerator/freezer
6. Installing the water heater
7. Installing the washing machine
8. Location

As we can see, there are eight titles in the above list, which means that there are only eight manuals showing the use of such a move. In terms of the words used to

make up the titles, there is a variety of numbers; that is, from one single word to the use of four words. In addition, the words used in the titles imply that the notion of ‘installation’ is conveyed using different set of words. Therefore, apart from the word ‘installation’, which conveys directly the notion of installation, there is the use of words as ‘assembly’, ‘prepare’ and ‘location’. Despite the variety of word meaning, these are used mainly to convey such information as how to install the product correctly in appropriate location before its use. Thus, the word ‘assembly’ does not mean that the product is completely disassembled, as in the process of repairing, but it rather means that it contains some accessories that need to be mounted on the product before use. On the other hand, using the word ‘prepare’ entails the installation of the product in the defined location. In addition, the word ‘location’ conveys explicitly that the coming information is about choosing the best location for the product. Knowing that, the prominent words used in the titles are ‘install’ and ‘prepare’. In here, the factor of word families is taken into consideration while counting the frequency of each word. That is, words as ‘install’ and ‘prepare’ appear to be in different forms than words as ‘installing’, ‘installation’ and ‘prepare, ‘preparation’. Thus, the form of each word is counted as one instance. As a result, the frequency of the words show that the words ‘install’ and ‘prepare’ are the prominent ones including a frequency of three times for each. The remaining two instances show one frequency for each namely ‘assembly’ and ‘location’. In addition, the names of the product also appear in the titles as the ‘hood’, ‘refrigerator’, ‘water heater’ and ‘washing machine’. The nouns used before the names are mainly gerunds, ending with (-ing), for instance, ‘installing’ and ‘preparing’.

The installation instructions are also conveyed through the use of visuals that help the reader/user to have a better understanding of the intended instructions. Since installation of the product is a very important step to do before the operation of the

product, the use of the visuals is to support the instructions that explain the process of the installation. Thus, the visuals are used differently depending on the intended meaning they seek to convey. In such case, the visuals are mainly to describe a process by showing the different steps that are to be followed by the reader/user. To make the point clear consider the following.

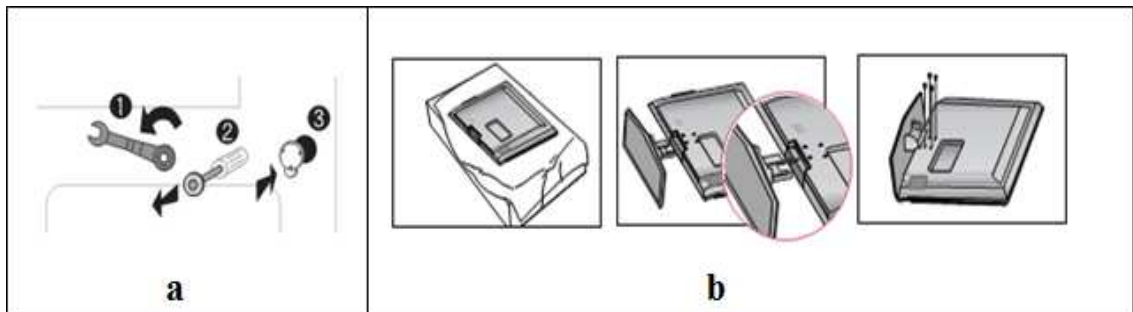

Figure 21. Visuals used to explain installation process

The figure (21) represents visuals extracted from user manuals namely of a washing machine (a) and a TV set (b). They explain clearly the process of installation for each product. That is, the first part (a) of the figure shows how to remove the shipping bolts before using the machine. The steps are numbered in chronological order as three steps. They include unscrew the bolt, removing them and covering the holes with plastic covers. Even without reading the instructions the three steps are clearly communicated through the visuals. In like manners, the second part (b) of the figure explains the process of preparing a TV set for use. Unlike the first part, this one does not use numbers to indicate the different steps for installations. It rather uses different images next to each other to express the order of the steps. They include, unpacking the product, setting the TV stand and securing it with bolts.

While this is true, the use of the visuals does not appear in all of the analysed instances of installation instructions. In fact, the eight analysed instances show that there are six cases that use visuals to support the installation instructions, depending

reasonably on the nature of the product. Thus, two instances that do not include the visuals are namely refrigerator and a heater. The installation of such products does not need visual; it is very simple and can be easily followed by the reader/user.

The installation instructions are also analysed to determine the more prominent sentence types used to convey such instructions. Therefore, the following table presents the sentence types in each manual that show the use of this move. Thus, the sample analysed represents 132 sentences used in the eight instances taken from the user manuals.

Sentence type		Frequency	Sentence total
1	Imperative	2	3
	Declarative	1	
	Conditional	0	
2	Imperative	19	28
	Declarative	9	
	Conditional	0	
3	Imperative	12	12
	Declarative	0	
	Conditional	0	
4	Imperative	10	13
	Declarative	3	
	Conditional	0	
5	Imperative	6	18
	Declarative	10	
	Conditional	3	
6	Imperative	15	27
	Declarative	8	
	Conditional	4	
7	Imperative	18	24
	Declarative	2	
	Conditional	4	
8	Imperative	5	6
	Declarative	1	
	Conditional	0	

Table 14. Sentence types in installation instructions

The above table (14) shows the frequency of each sentence type namely imperative, declarative and conditional. Additionally, it provides the number of sentences that represents the installation instructions in each of the eight instances extracted from the user manuals. Thus, the lowest number of sentences, used as to

convey installation instructions, is three while the highest number used for the same purpose is twenty-eight. The prominent sentence types in the eight instances of installation instructions are the imperative and declarative. The third type, which is conditional, tends to be less used in this kind of instructions. The following table provides the frequency of each sentence type in the eight analysed instances.

Sentence type	Frequency in 132 sentence
Imperative	87
Declarative	34
Conditional	11

Table 15. Sentence type frequency in 132 sentences

Clearly, the table (15) shows that the imperative is mostly used in the installation instructions hence it has 87 frequency of use in the 132 sentences that represent the sample of the installation instructions. The second more frequent sentence type is declarative sentences that appear 34 times in the analysed sample. The less frequent sentence type in the installation instructions, apparently, is conditional sentences since it occurs only 11 times. Knowing that, the use of imperative sentence in such a frequency implies that the reader/user must, completely, follow the information provided by this move. That is, the reader/user has no choice but to follow the instructions so that to install the product correctly and thus, prepare it for use. The incorrect installation is more likely to lead to bad consequences including damaging the product or even injuring the user. So, in order to force the user to follow the instructions, the imperative is best suited for such consideration. Although most of the sentences are in the imperative mood, the instructions are also conveyed by the use of declaratives and conditionals. They both guide the reader/user and provide him with the needed information that results in an appropriate installation. However, as shown in the table

(19), this kind of information is mostly conveyed by the use of declaratives sentences as opposed to conditional ones. In fact, declarative sentences are to support the reader/user with additional information so that to achieve the defined task.

Furthermore, to have a much better understanding of the nature of vocabulary used in this move, the data extracted from the installation instructions of the user manuals is submitted to the vocabulary profiler. It helps to reveal the use of function and content words, in addition to the academic words. To give it more substance, consider the following table.

	<u>Families</u>	<u>Types</u>	<u>Tokens</u>	<u>Percent</u>
K1 Words (1-1000):	237	307	1523	67.15%
Function:	(983)	(43.34%)
Content:	(540)	(23.81%)
> Anglo-Sax	(266)	(11.73%)
=Not Greco-Lat/Fr Cog:		
K2 Words (1001-2000):	103	132	231	10.19%
> Anglo-Sax:	(125)	(5.51%)
1k+2k		(77.34%)
AWL Words (academic):	59	81	142	6.26%
> Anglo-Sax:	(19)	(0.84%)
Off-List Words:	<u>?</u>	<u>153</u>	<u>372</u>	<u>16.40%</u>
	399+?	673	2268	100%

Table 16. Vocabulary profile of installation instructions

Following the vocabulary profiler, the vocabulary that build up the installation instructions include 77.34% of the 2000 words common in English. Precisely, 67.15% belongs to the first range represented by K1 (1-1000) and 10.19% to second range that is K1 (1001-2000). Therefore, in terms of common used words, the installation instructions have more words that appear in the first range K1 than those that appear in second K2. In addition, the words that are classified under K1 tend to be of two types namely function and content words. Thus, out of 67.15% there is the use of 43.34% of

function words and 23.81% of content words. In fact, the K2 words represent only 10.19% of the vocabulary used in the installation instructions of the analysed manuals. This means that the words, used in the installation instructions that appear in the first range of 2000 words are mainly function words. Moreover, academic words used in the constructions of the instructions hence they represent 6.26% in the analysed vocabulary. Although most of the words are from the 2000 common words, the installation instructions also make use of technical words as a part of its vocabulary. More particularly, 16.40% refer to technical words that are identified as Off-list words and not recognised by the vocabulary profiler, neither as common words nor as academic ones.

We can also consider that the reader/user is more likely to understand most of the vocabulary used in the installation instructions since the 77.34% of the words are common English words. Moreover, assuming that the reader/user is familiar with the 6.26% of the academic words used in the instructions, the reader/user is expected to understand 83.60% of the words used in the installation instructions. This consideration leaves him only with 16.40% of the words, which he may be less familiar with.

5.1.7. Operating instructions

This move represents the heart of the user manuals since it provides the necessary instructions to operate the product at hand. The instructions conveyed by this move guide the reader/user through a set of defined steps that have to be followed in order to use the product correctly. Therefore, the instructions used to fulfil such purpose are analysed in terms of sentence structure. In addition, the vocabulary that builds up the instructions is submitted to the vocabulary profiler to reveal the types of vocabulary used including function, content and academic words.

To start with, the first thing that the reader/user come into contact while going through the instructions of operating the product is the title of the move; in this case, it is 'operating instructions'. Titles are very useful hence they give the reader/user an overview of what he is going to read. Additionally, they serve to catch the reader/user attention. As they are the head of the instructions, they must be informative enough to make the reader/user willing to read. When we consider the following titles extracted from 15 user manuals of household equipment, we can see that the titles are a part of the operating instructions move, which is identified in the 15 user manuals.

1. Operation
2. Operating instructions
3. Selecting a program and operating your machine
4. Ironing
5. Dry your hair
6. Operation
7. Watch TV/channel control
8. Using the control features
9. Washing a load of laundry
10. Operating the water heater
11. Operating instructions
12. Using your microwave oven
13. Turing the power on and setting the date
14. Using your sewing machine
15. Turing on

In the move of operating instructions, the titles appear first; thus, their use is to signal that the information to be provided is mainly about operating instructions. The

titles show a diversity of structure and include different set of words. In addition, the number of words used in the titles varies from manual to another. That is, they range from a single word to eight words, as shown in the above list of titles. Before dealing with the structure of titles, more light is shed on the words used in their constructions. Since they convey a very important piece of information, it is very convenient to consider their nature and choice first. The titles show that there are different words used at the beginning of the title varying from one manual to another. That is, the main words used are 'operation', 'using', 'selecting', 'dry', 'ironing', 'watch', and 'turning'. Although there are different words used in the beginning of the titles, some of them tend to be more prominent than others. Considering the titles, the most frequent words are namely 'operating' and 'using'. Unlike the remaining words including 'selecting', 'dry', 'ironing' just to mention some, both words show a significant frequency that is of six and three respectively. Apart from these two words, the other words are only used once; hence, there is a preference to use these words, that is 'operating' and 'using', more than using other words. Since the move is primary about the operation and the use of the product, the use of such words convey the intended meaning directly and effectively to the reader/user.

Moreover, the words that appear in the titles are of different categories; they vary from nouns to verbs. For instance, 'operation' and 'dry' are used in (1) and (5), represent a noun and a verb respectively. It seems that verbs are also used as a noun in a different category of words. Such use is generally possible through the use of gerund i.e. adding (-ing) to the words. Bearing this in mind, the analysed titles show that, most of the titles use a gerund as the first word. Thus, from the 15 titles, which appear in the move of operating instructions, 11 titles show the use of gerund as the first word. The remaining 4 instances of titles use nouns and verbs instead; more precisely, two

instances of nouns and two of verbs. So, gerund is more preferred, in the analysed titles, than the other category of words namely verbs and nouns. The reason behind such a use lies in the fact that gerund conveys the meaning of a process as opposed to verbs, for instance, which are used as an imperative. Thus, the use of the verb stem in titles may confuse the reader/user hence it makes him think that the title is an imperative instruction. For example, consider the case of (5) where there is the use of verb stem to form the title as “dry your hair”. In fact, the title is not an imperative that asks the reader/user to dry his hair first but instead it is used as a title to convey that the coming information includes how to dry his hair using the product that is the hair dryer. The same thing can be said about (7) where there is also the use of verb as “watch TV”. On the other hand, the use of gerund gives more clarity to the reader/user that the information provided explains the process of doing the task. Let us consider the case of (4) where the title is expressed by a single word that is “ironing”. Although it is one word, in a gerund form, it is informative enough and hence it communicates to the reader/user that the next information includes primarily the process of ironing. In addition, knowing that the title conveys a process is very likely to imply that there is a different set of steps to be followed so that to achieve the task intended to the reader/user. As a result, titles tend to be expressed as a process by using gerund instead of verb stem that can be understood as imperative, which may mislead the reader/user.

After discussing the nature of the words used in the titles, it is worth considering their arrangement. That is, how they are combined to construct very informative titles, which help the reader/user to find the intended information. Taking into account the early discussion, most of the titles are constructed using nouns including verbs in the form of nouns, namely gerunds. However, the use of verbs, in the analysed titles, seems

to be limited to two instances of titles as shown in (5) and (7). To give it more substance, the structure of the titles can be represented as the following.

- Noun /+ noun
- Verb + noun
- Gerund + noun

These are the main structures that represent the titles that show the information of operating instructions. The presence of nouns after the first word, be it noun, verb, or gerund, is to be expected hence the construction of the titles is based on nominalisation. Thus, regardless of words used in the titles nouns are to represent most of them. Even if the title is made up of a single word, it is very likely to be a noun as it is the case in (1). The use of the slash in first category is to show that noun can be used alone as a single word without adding another one. In spite of that, titles, in fact, do include more than nouns. Thus, they also include functional or grammatical words. They are used to combine the words together to form a title. The identified grammatical words in these titles are represented by the use of definite/indefinite articles, conjunctions, prepositions and pronouns. More particularly, they are: ‘a/the’, ‘and’, ‘your’ and ‘on, of’. In addition, some of the analysed instances indicate precisely the nature of the product intended for operation. That is, titles represented by (10), (12) and (14) involve the product name as “operating the water heater”, “using your microwave oven” and “using your sewing machine”.

Defining the nature of the product in the titles can also mean that the information provided for the product operation are only to be used with the product at hand and not with another product even if it is of the same type. For instance, operating instructions intended for a water heater can only be used to operate the water heater at

hand and not another water heater. This consideration is very important for the user and product safety. In other words, trying to operate another product, in this case a water heater, may lead to bad consequences; hence, what applies to one product does not necessarily apply to the other. In addition, most of the titles do not show such a precision to the nature of the product. Instead, they use more general words such as “operating instructions” or “selecting a program and operating your machine”. Although they clearly convey that the provided information is about using the product, they do not mention the nature of the product. Using titles in this way means that the nature of the product is assumed by the reader/user to be the actual product at hand and not another one. That is, for instance, when reading a manual of water heater or washing machine, the reader/user knows already and obviously assumes that the information is intended for the water heater or the washing machine. However, including the nature of the product in titles gives more emphasis to the reader/user.

Although the titles give the reader/user an understanding of the nature of the information at hand, they do not really tell him what to do and what not to do. Thus, titles are used to grasp the attention of the reader/user hence they signal the piece of the information that comes next. In this move, the information presented by the titles is to make sure that the reader/user reads the information provided as operating instructions. In what follows the operating instructions extracted from the fifteen analysed manuals are represented in the following table.

Manuals	Sentence types	Frequency	Total of sentences 368
1	Imperative	7	17
	Declarative	9	
	Conditional	1	
2	Imperative	11	17
	Declarative	4	
	Conditional	2	
3	Imperative	6	19
	Declarative	12	
	Conditional	1	
4	Imperative	12	19
	Declarative	6	
	Conditional	1	
5	Imperative	4	4
	Declarative	0	
	Conditional	0	
6	Imperative	7	13
	Declarative	6	
	Conditional	0	
7	Imperative	14	20
	Declarative	4	
	Conditional	2	
8	Imperative	6	18
	Declarative	10	
	Conditional	2	
9	Imperative	10	31
	Declarative	17	
	Conditional	4	
10	Imperative	27	40
	Declarative	11	
	Conditional	2	
11	Imperative	22	40
	Declarative	13	
	Conditional	5	
12	Imperative	8	30
	Declarative	20	
	Conditional	2	
13	Imperative	8	35
	Declarative	19	
	Conditional	8	
14	Imperative	20	37
	Declarative	12	
	Conditional	5	
15	Imperative	13	28
	Declarative	11	
	Conditional	4	

Table 17. Analysis of operating instructions according to sentence types

The above table (17) shows the analysis of the operating instructions provided by the 15 manuals, includes the number of sentences analysed in each manual and the different set

of sentence types used in the instructions along with their frequency of use. For a better understanding of the data presented in this table the following one (table 22 below) sheds light on the frequency of each sentence type used in the operating instructions of the manuals.

Sentence type	Frequency in 368
Imperative	175
Declarative	154
Conditional	39

Table 18. Sentence types frequency

Table (18) provides the three types of sentences used in the operating instructions with a frequency of use in 368 sentences extracted from the instructions of fifteen user manuals namely the operating instructions. Considering the frequency of use shown by the table, there is an overwhelming use of the imperative sentences. From the total number of sentences extracted for the analysis, that is 368, the imperative represents 175 sentences. However, the imperative is not the only used one hence there is other sentence type as the declarative that appears with a remarkable frequency. In fact, the declarative sentences show its significance in the operating instructions through 154 occurrences. In addition to the imperative and declarative that consist most of the operating instructions, the conditional as a sentence type is also used in these instructions and is meant to convey the operating information to the user/reader. Although it is not used as the first two types, namely the imperative and declarative, it takes part in the constructions of the operating instructions in 39 sentences from the overall analysed sentences of the user manuals. Thus, we can say that the imperative is the mostly used sentence type in the operating instructions of the manuals.

The sentences conveying the instructions of operation are also considered in terms of their vocabulary. Therefore, the vocabulary profiler is used to determine the

types of vocabulary including functional and content words, academic and technical words. To give it substance, the following table shows the results obtained from submitting the instructions, namely of operating, to the vocabulary profiler.

	<u>Families</u>	<u>Types</u>	<u>Tokens</u>	<u>Percent</u>
K1 Words (1-1000):	354	509	3573	68.95%
Function:	(2221)	(42.86%)
Content:	(1352)	(26.09%)
> Anglo-Sax	(576)	(11.12%)
=Not Greco-Lat/Fr Cog:		
K2 Words (1001-2000):	132	170	554	10.69%
> Anglo-Sax:	(254)	(4.90%)
1k+2k		(79.64%)
AWL Words (academic):	93	126	351	6.77%
> Anglo-Sax:	(37)	(0.71%)
Off-List Words:	<u>?</u>	<u>369</u>	<u>704</u>	<u>13.59%</u>
	579+?	1169	5182	100%

Table 19. Vocabulary profiler of operating instructions of 15 manuals

The table (19) gives a clear image about the nature of the vocabulary used in the operating instructions extracted from the fifteen user manuals. Thus, the vocabulary used to convey the instructions has 79.64% of the words belong to the common English words appearing as K1 and K2 in the table. Precisely, 68.95% of the words are in the first range of common words i.e. K1 (1-1000). The second range that is K2 (1001-2000) of the common words includes only 10.69% of the words used in the instructions vocabulary. In addition, the first range that represents 68.95% of the vocabulary consists of two categories including functional and content words. In other words, the 68.95% of the vocabulary in the K1 includes 42.86% functional words and 26.09% content words. There is, of course, more use of functional words than content ones; it implies that the vocabulary of the K1 is more likely to be understood by the reader/user. Besides, the vocabulary of the analysed operating instructions also includes academic words. That is, 6.77% of the instructions' vocabulary belongs to the academic words. In addition, the

analysis of the vocabulary shows the use of technical words. The latter is represented by the Off-list words as shown in the table. The technical words represent 13.59% of the words used to build up the vocabulary of the operating instructions of the fifteen user manuals.

Taking this into consideration the reader/user is familiar with most of the vocabulary used to convey the operating instructions. Even though there are technical words used in the vocabulary of the instructions, the reader/user can still understand the instructions intended to operate the product. Since one of the communicative purposes of the manuals is to instruct the reader/user how to use the product properly, the vocabulary used in the instructions must be clear and appropriate to the level of the intended audience in this case it is a user with general background knowledge, referred to as the layman. In addition, the technical words depend on the complexity of the product itself. Thus, more complicated product or machines may include many technical words hence these technical words are used generally to describe or name the different parts of the product. To ensure that the reader/user understands the instructions given to him through the manuals the technical words are explained along within the instructions.

5.1.8. Cleaning and maintenance

1. Care and cleaning
2. Maintenance and service
3. Maintenance and cleaning
4. Cleaning and maintenance
5. After use
6. Maintenance and cleaning
7. Maintenance

8. Removing and cleaning accessories
9. Care and cleaning of the water heater
10. Maintaining the washing machine
11. About handling of your camcorder
12. Maintenance
13. Care and cleaning
14. Maintenance
15. Maintenance and service

The above titles are used in user manuals in order to indicate ‘maintenance move’. The titles are extracted from the fifteen user manuals intended for the analysis. Since titles are the first thing to communicate information to the reader/user, it is worth to analyse their structure and the nature of the vocabulary used to convey their intended meaning. The number of words used in the titles differs from one manual to another. Thus, the titles are constructed using one to seven words. The main words used in the titles include ‘care’, ‘cleaning’ and ‘maintenance’. These words explain clearly that the information to be presented is mainly about maintenance of the product. In addition, the words are related to each other in the sense that one suggests the other. That is, ‘maintenance’ itself includes ‘care’ and ‘cleaning’ of the product; hence this process is mainly achieved through these two actions. Therefore, the most frequent word used in the titles is ‘maintenance’ since it appears in 8 instances of the analysed titles. Similar in importance, the word ‘care’ is used in 7 of the fifteen titles. However, the word ‘cleaning’ is less frequent in these titles. In terms of frequency ‘cleaning’ appears only in three instances of titles.

As mentioned before, the cleaning process is a part of maintenance, which helps keeping the product in a good condition. For some products, cleaning needs

special steps to be followed so not to damage the product. This assumption depends, primary, on the nature of the product. That is, cleaning electrical equipment with water may result in damaging the product and injuring the user as well. In such cases where cleaning must be carried with care, the titles include the word ‘cleaning’ along with the word ‘maintenance’ in order to tell the reader/user that the product at hand needs appropriate cleaning that avoids any risks as damaging the product or hurting the user. In spite of that, some of the titles are constructed using as few words as possible, which is the case for the title (12) where there is only the use of one word. To do so, the titles are constructed using nouns and gerunds. Thus, most of the titles in the manuals are based on nouns or a combination of nouns and gerund. To make it clear, titles can be represented as follows:

Noun + noun

Gerund +noun

Noun +gerund

Knowing that, the nouns and gerunds are, in fact, represented by the frequent words discussed earlier namely ‘maintenance’ and ‘cleaning’. In addition to their frequency of use, these words have the same pattern of use in titles. On the one hand, the word ‘maintenance’ is used as a noun while the word ‘cleaning’ is used as a gerund throughout the fifteen analysed titles. ‘Maintenance’ is used as a general term that involves different tasks to be performed in order to ensure the good performance of the product. Thus, the appropriate word to convey such notion is the use of the noun ‘maintenance’. On the other hand, ‘cleaning’ is a process including different steps that must be followed by the user. Thus, there is only one task, in this case, to be performed by the user. Therefore, using a gerund as ‘cleaning’ is to convey to the reader/user that

there is a process involved. In addition, the use of gerund in this case is more convenient than using a noun since it may confuse the reader/user because they sound more like imperatives that enforces the reader to do the defined task.

The instructions given to the reader/user are expressed through the use of different types of sentences. Regardless of the sentence type, each of which is used according to the type of the information presented to the reader/user. Thus, the way information is presented to the reader/user affects the way he performs the actions assigned to him through the instructions. Taking this into consideration, the instruction that contains maintenance information is based on three sentences types namely imperative, declarative and conditional. The imperative is used to express direct instructions that indicate that the actions must be performed by the reader/user. The other two types, declarative and conditional, are used to give additional information that helps him performing the assigned actions correctly. They are also used to warn him of any possible danger if the actions are not well performed on the part of the reader/user.

Knowing their importance, the three sentence types are analysed in the instructions of maintenance in order to reveal their frequency of use and to know the most prominent sentence type in these kinds of instructions. To do so, the maintenance instructions are extracted from fifteen user manuals. The length and number of sentences used in each manual to convey the maintenance instructions varies from one manual to another. In addition, the maintenance information depends also on the nature of the product. For instance, in the case of a hair dryer there is not much to say about maintaining this product. However, considering more complicated products such as a microwave oven, the reader/user needs to know exactly every step included in the maintenance of such equipment because he may end up causing damage or injuries.

After collecting the maintenance instructions and submitting them to the analysis, the results obtained are clearly shown in the following table. It includes sentence types and their frequency of use in the manuals. In addition, it shows the number of sentences that represents the maintenance information for each manual.

	Sentence types	Frequency	Number of sentences
1	Imperative	66	72
	Declarative	3	
	Conditional	3	
2	Imperative	27	39
	Declarative	10	
	Conditional	2	
3	Imperative	23	39
	Declarative	12	
	Conditional	4	
4	Imperative	11	16
	Declarative	4	
	Conditional	1	
5	Imperative	5	5
	Declarative	0	
	Conditional	0	
6	Imperative	25	28
	Declarative	3	
	Conditional	0	
7	Imperative	7	10
	Declarative	2	
	Conditional	1	
8	Imperative	22	28
	Declarative	6	
	Conditional	0	
9	Imperative	30	65
	Declarative	28	
	Conditional	7	
10	Imperative	22	23
	Declarative	0	
	Conditional	1	
11	Imperative	48	123
	Declarative	58	
	Conditional	17	
12	Imperative	47	52
	Declarative	4	
	Conditional	1	
13	Imperative	16	20
	Declarative	2	
	Conditional	2	

14	Imperative	32	35	
	Declarative	2		
	Conditional	1		
15	Imperative	6	8	
	Declarative	2		
	Conditional	0		
Total of each type		Imperative	387	563
		Declarative	136	
		Conditional	40	

Table 20. Sentence types frequency in maintenance instructions

As shown in the table (20) the number of sentences being analysed is 563 sentences. The maintenance information provided to the reader/user is conveyed through these sentences. Their number varies from one manual to another. Thus, some manuals devote only 5 sentences to instruct the reader/user about maintaining the product, while others use 123 for the same purpose. In spite of the number of sentences used to express maintenance information, there are different types of sentences, namely imperative, declarative and conditional, used to inform the reader/user about maintenance. With reference to the table (20), there is a variation in their frequency of use. Therefore, the imperative sentences tend to be the most frequent of the three identified types. Thus, out of 563 sentences, 387 of them represent imperative sentences. This means that most of the information conveyed to the reader/user is expressed through the use of the imperative sentences. Even though the reader/user is provided with the tasks he has to do through direct instructions using the imperative, there is still other information that needs to be conveyed through indirect instructions using declarative and conditional sentences. As the second most frequent type, declarative sentences show its presence through 136 sentences in the maintenance instructions. In fact, this type of sentences provides the reader/user with additional information that generally explains why he has to perform such a task. Thus, they are necessary to guide the reader/user to perform the task appropriately. Conditionals are used to warn the user about a potential danger or the consequences that may result from

malfunction or misuse of the product at hand. Although they are not as frequent as the imperatives or declaratives, conditional sentences show a significant presence in the instructions of maintenance. They appear in 40 instances of the overall instructions, which are devoted to make the reader/user aware of the importance of maintaining his product in a good condition.

Given that the instructions of maintenance are conveyed through three different types of sentences, it implies that each of type participates in the task of instructing the reader/user and making him understand easily the intended instructions. To do so, the vocabulary must be chosen with care. Thus, the more the vocabulary is simple the more likely the reader/user is to understand the defined instructions. In order to know the nature of the vocabulary used in the instructions of maintenance, the vocabulary profiler is involved in the analysis of these instructions. It gives clear image about whether the vocabulary is suited to the reader/user or not. The profiler analyses the instructions considering their vocabulary in terms of common English words including functional and content words. In addition, it identifies the academic words and technical ones. The results of the analysis are presented in the following table, which includes each vocabulary type along with a percentage that shows how much each type is used to construct the vocabulary of maintenance instructions.

	<u>Families</u>	<u>Types</u>	<u>Tokens</u>	<u>Percent</u>
K1 Words (1-1000):	387	542	4171	65.36%
Function:	(2644)	(41.43%)
Content:	(1527)	(23.93%)
> Anglo-Sax =Not Greco-Lat/Fr Cog:	(763)	(11.96%)
K2 Words (1001-2000):	154	214	848	13.29%
> Anglo-Sax:	(527)	(8.26%)
1k+2k	(78.65%)
AWL Words (academic):	83	113	279	4.37%
> Anglo-Sax:	(55)	(0.86%)
Off-List Words:	<u>?</u>	<u>441</u>	<u>1084</u>	<u>16.99%</u>
	624+?	1309	6382	100%

Table 21. Maintenance instructions vocabulary profiler

The vocabulary used in the sentences conveying the maintenance information is analysed with the vocabulary profiler. The results of the analysis, as shown in the table (21), give a clear image about the vocabulary structure. That is, the words representing the maintenance vocabulary consist of a variety of categories including function and content words. In addition, there is the use of academic and technical words. More particularly, the vocabulary of the maintenance instructions is build using 78.65% of English common words. Thus, 65.35% of the words, used in the vocabulary of maintenance, are from the first range K1 (1-1000) and 13.29% from the second rage K2 (1001-2000). As mentioned before, the vocabulary shows a use of content and function words. The words identified in the first range K1 are based on the two categories of content and function words. To put it other way, the 65.36% in the first range includes 41.43% function words and 23.93% content words. This means that there is more use of the function words than the content ones. So, the reader/user is more likely to understand the information expressed through these words hence most of them are function or grammatical words that are familiar to him. Although most of the words

belong to the common words, the academic words have its own share in the vocabulary of maintenance. Such words appear as 4.37% in the constructions of the vocabulary. Furthermore, the maintenance information presented to the reader/user is not free from technical words. There is a use of 16.99% of such words. As indicated in the table, the profiler shows them as off-list words hence they are not identified as common words or academic words.

5.1.9. Troubleshooting

1. TROUBLESHOOTING
2. Troubleshooting Tips! Save time and money!
3. Solution suggestions for problems
4. Trouble-shooting guide
5. TROUBLESHOOTING
6. PROBLEMS AND SOLUTIONS
7. Before You Call For Service...
8. Troubleshooting
9. Troubleshooting
10. TROUBLESHOOTING
11. TROUBLESHOOTING
12. TROUBLESHOOTING

The titles presented above are extracted from twelve user manuals. Thus, not all of the fifteen analysed manuals include troubleshooting. In fact, three manuals do not have troubleshooting information. Since titles are the first thing to be read, the reader/user is more likely to check them first because they tell him what kind of information is being presented. Their role is to make information access easier. Knowing their importance in the manuals, it is worth considering their nature in terms

of structure and the vocabulary used to make such titles. The structure of titles and the words involved in their construction varies from one manual to another. That is, the structure of the titles shows different patterns of structure and not only one pattern shared by all the manuals. In addition, depending on the manual style's preferences, the choice and number of words differ as well; there are titles that consist of a single word and others of five or six words. Out of the twelve identified titles, seven of them have single word titles while five titles have more than one word. Since titles are the first thing to be communicated to the reader/user, choosing the appropriate words is very important in their construction. Therefore, in these identified titles, the word 'troubleshooting' is used more than other possible words such as 'problems and solutions'. In fact, 'troubleshooting' appears in nine of the twelve titles. Moreover, it represents the seven cases of single word titles. Although there are titles that use more than the word 'troubleshooting', as in the case of (2), it is clear for the reader/user that the word 'troubleshooting' refers to the solutions of problems that may occur during or after the operation of the product. Since the information included in the troubleshooting is problems and their suggested solutions, some manuals prefer to use 'problem and solution', which is the case for (6), as a title to indicate troubleshooting of the product.

In spite of that, some of the titles do not show neither the use of 'troubleshooting' nor 'problems and solution' they instead use different words as in the case of (7) which prefers to use 'before you call for service'. Using such a title for troubleshooting is to prevent the reader/user from calling the service before trying the suggested solutions provided by the manual. The reason behind this is that the problem may be not serious enough to call for service hence it can be fixed following the steps explained in the troubleshooting instructions. In addition, doing so saves the reader/user

time and money. In fact, this consideration can be explicitly stated in titles as in the case of (2) (Troubleshooting Tips! Save time and money!).

With that being said, titles include different categories of words. The frequent ones are, mainly, nouns and gerunds. The use of such categories is very important in the construction of titles. On the one hand, they serve to reduce the number of words used to convey the intended information to the reader/user. On the other hand, they help to keep the information provided by the titles as clear and direct as possible. Thus, the most used category, in the twelve identified titles, tends to be the gerund. It is used in most titles regardless the number of words they have, either one word or more. Furthermore, a combination of a gerund and a noun is possible to create titles, as in the cases of (2), (4). However, in some titles there is a preference to use nouns alone without the interference of gerund as in the instances of (3), (6) and (7). In fact, the titles that use gerund include only one word, which is ‘troubleshooting’, whereas titles that do not use the word ‘troubleshooting’ use only nouns in their constructions. The reason behind this is that the titles that involve only nouns cannot use these words as gerund. Thus, ‘problems and solutions’ cannot be used as gerund with –ing. What is more, such words do not indicate a process but rather two separate pieces of information. Unlike the use of nouns, gerund implies the involvement of a process. The use of ‘troubleshooting’ alone is enough to communicate to the reader that, there is a process including different steps that guide him to find the appropriate solution for the problems that may interfere in the good performance of the product.

Although titles are very important to the reader/user to know the kind of information being described, they do not make him fix the problems in the product. So, what he needs to know is the instructions that enable him to troubleshoot the product. Such information is conveyed through different types of sentences using different types

of words. Therefore, analysing the nature of sentences and the vocabulary used in their constructions help to understand how the reader/user perceives the information expressed through the use of such sentences. To make the image clear, consider the following table.

	Sentence types	frequency	Number of sentences
1	Imperative	25	55
	declarative	30	
	Conditional	0	
2	Imperative	5	22
	declarative	13	
	Conditional	4	
3	Imperative	20	53
	declarative	33	
	Conditional	0	
4	Imperative	6	10
	declarative	4	
	Conditional	0	
5	Imperative	28	48
	declarative	17	
	Conditional	0	
	interrogative	3	
6	Imperative	7	32
	declarative	15	
	Conditional	0	
	interrogative	10	
7	Imperative	25	66
	declarative	41	
	Conditional	0	
8	Imperative	16	22
	declarative	5	
	Conditional	1	
9	Imperative	26	60
	declarative	29	
	Conditional	5	
10	Imperative	32	65
	declarative	14	
	Conditional	10	
	interrogative	9	
11	Imperative	41	99
	declarative	57	
	Conditional	1	

12	Imperative	72	155
	declarative	76	
	Conditional	7	
Total of each type	Imperative	303	687
	Declarative	334	
	Conditional	28	
	Interrogative	22	

Table 22. Sentence types of troubleshooting instructions

As shown in the table (22), the troubleshooting instructions extracted and analysed from twelve manuals represent 687 sentences. The latter includes a variety of sentence types namely imperative, declarative and conditional. In addition to these three types of sentences, there is a use of another type that seems to be used significantly in troubleshooting instructions. Unlike the so far discussed instructions, the troubleshooting instructions make use of interrogative sentences to convey troubleshooting information to the reader/user. In an attempt to fix the problem, the reader/user tries first to know its cause. To help the reader/user doing so, troubleshooting information provides him with all the possible causes that are related to the problem at hand. In some manuals, there is a preference to use questions to determine the problem. While the cause of the problem is expressed through declarative sentences, interrogative sentences serve as instructions that guide the reader/user to fix the problem. In fact, the questions are to make the reader/user check different parts in the product that may cause the problem. If any of the questions represent the case for the user's problem, inspecting the parts mentioned in the question can easily solve it. Thus, the interrogative sentences are very useful to present troubleshooting information as questions and answers. Since not all the manuals use such method to convey troubleshooting instructions, the use of interrogative sentences is restricted to 22 sentences.

In spite of that, the instructions of troubleshooting still show a significant use of the other three types namely imperative, declarative and conditional. As opposed to

other types of instructions, troubleshooting instructions tend to be more represented by declarative sentences rather than imperative ones. Although the imperative sentences are used significantly in these instructions, there is an overwhelming use of declarative sentences. That is, out of 687 sentences representing troubleshooting instructions, 334 sentences are declaratives. In spite of that, the imperative sentences are not less significant hence they appear in 303 instances of the troubleshooting instructions. The rest of the sentences are expressed through conditional, which is used in 28 sentences. As a result, troubleshooting instructions are mainly expressed through declarative and imperative sentences.

The reason behind the overwhelming use of declarative sentences lies in nature of the instructions, which is troubleshooting. In order to convey such information to the reader/user, the manuals, regardless of their differences, use a kind of shared method or pattern of presenting information. Thus, the instructions are structured using the same pattern, which includes the following items as ‘problem’, ‘cause of the problem’, and ‘suggestion’s or, ‘solutions’. As mentioned before, some manuals prefer to use ‘questions and answers’ method. For more clarity, consider the following figure.

Problem	Cause	Explanation / Suggestion
Drying process takes too much time.	Cover filter and filter drawer might have not been cleaned.	* Clean the cover filter and Filter drawer.
Laundry come out wet at the end of drying.	* Cover filter and filter drawer might have not been cleaned. * Excessive laundry might have been loaded in.	* Clean the cover filter and Filter drawer. * Do not overload the machine.

A

QUESTION	ANSWER
Can I use a rack in my microwave oven so that I may reheat or cook in two rack positions at a time?	Only use the rack that is supplied with your microwave oven. Use of any other rack can result in poor cooking performance and/or arcing and may damage your oven.
Can I use either metal or aluminum pans in my microwave oven?	Usable metal includes aluminum foil for shielding (use small, flat pieces). Never allow metal to touch walls or door.

B

Figure 22. Troubleshooting using two patterns

The above figure (22) shows how troubleshooting information is presented to the reader/user using two patterns. The first one refers to ‘problem-cause-solution’, as in (A), and the second one to ‘question-answer’ as in (B).

As shown in figure (22-A), troubleshooting information is most of the times presented in a table that includes the aforementioned information. How can this be related to the overwhelming use of declarative sentences? Each item in the table of troubleshooting information is characterised by a sentence type or a combination of types. However, for the first and second items, which are the ‘problem’ and the ‘cause of the problem’, they tend to follow one type of sentences. In most of the twelve analysed manuals, the declarative sentences are used to express the information provided under the items ‘the problem’ and ‘cause of the problem’. On the other hand, information that represents ‘solutions’, for the problems, is mainly conveyed through the imperative sentences.

As solutions for the problems are the tasks needed to be performed by the reader/user, the appropriate sentence types to convey such information is through the use of imperatives. In spite of that, a combination of sentence types is also possible in such kind of information. Thus, there is the use of declarative and conditional along with the imperative in the information provided by ‘solutions’. So, declarative sentences are used mostly in troubleshooting information due to the fact that ‘problem’ and ‘cause of the problem’ are mainly descriptive information. In other words, they state the problem and give possible causes. Providing such information to reader/user is more likely to help him identifying and fixing the problem at hand. Although solutions for the problems are mainly expressed by the imperative, declarative sentences are also used to convey such information. This fact clearly increases its occurrence in troubleshooting instructions.

Using such variety of sentence types to express troubleshooting instructions implies that there is a variety of vocabulary involved in their constructions. The vocabulary plays a crucial role in communicating information to the reader/user. Thus, the more appropriate the vocabulary is, the more likely the reader/user is to understand the instructions. Knowing this, the vocabulary used in troubleshooting instructions must match the reader/user background knowledge. In order to reveal such assumption, the vocabulary used in troubleshooting information is analysed using vocabulary profiler. It gives a clear image about the nature of the vocabulary used in troubleshooting instructions hence it identifies different categories of words including common English words, academic words and technical words.

For much better understanding, consider the following table that represents the results obtained from analysing troubleshooting vocabulary.

	<u>Families</u>	<u>Types</u>	<u>Tokens</u>	<u>Percent</u>
K1 Words (1-1000):	338	465	3973	65.62%
Function:	(2332)	(38.51%)
Content:	(1641)	(27.10%)
> Anglo-Sax =Not Greco-Lat/Fr Cog:	(634)	(10.47%)
K2 Words (1001-2000):	144	196	762	12.58%
> Anglo-Sax:	(470)	(7.76%)
1k+2k		(78.20%)
AWL Words (academic):	86	116	313	5.17%
> Anglo-Sax:	(19)	(0.31%)
Off-List Words:	<u>?</u>	<u>325</u>	<u>1007</u>	<u>16.63%</u>
	568+?	1097	6055	100%

Table 23. Vocabulary profiler for troubleshooting instructions

The above table, clearly, provides the percentage of use for each category of words. The first category identified in the table is the common English words. Precisely, they are divided into two sub-lists referred to as K1 and K1. As indicated in the table, 78.20% of the words used in troubleshooting instructions belong to the English common words. Such percentage is the combination of K1 and K2. In other words, 65.62% of the words used in troubleshooting appear in the first list i.e. K1 and 12.58% belong to the second list K2. Moreover, the common English words identified in troubleshooting instructions consist of two sub-categories namely function and content words. The first range of English common words, which is K1, shows that out of 65.62% there is a use of 38.51% of function words and 27.10% of content words. Thus, function words are used more than content words. It implies that the reader/user is likely to understand most of the words without any difficulty. That is, 78.20% of the words is familiar to the reader/user hence they represent the common words in English. In addition, troubleshooting involves the use of academic words. They represent 5.17% of the words used to build the vocabulary used to convey troubleshooting information.

Apart from the familiar vocabulary to the reader/user, there is also the use of less familiar vocabulary, which refers to technical words. In fact, the profiler represents them by an Off-list category, since they are not recognised as common words or as the academic words. As a result, the profiler shows that 16.63% of troubleshooting vocabulary is to be considered as technical words.

5.1.10. Warranty

1. LG Vacuum Cleaner Warranty
2. Guarantee
3. One Year Limited Warranty
4. Guarantee and Service
5. Limited Warranty to Original Purchaser
6. End-User License Agreement For Map Data For Video Camera Recorder Products
7. LG Microwave Oven Limited Warranty
8. Dishwasher Limited Warranty
9. Limited Warranty

The warranty of the product is very important to both the user and the company because it clarifies the liability of the company in case of product defect. With a view to understand how such information is conveyed to the reader/user, the titles above are first considered in the analysis because they are the first to appear in the warranty. In addition, they clearly state the type of warranty provided by the company. Thus, the titles include the words 'limited warranty' to tell the reader/user right at the beginning that the warranty does not involve the replacement or repair of every part of the product in case of defect. Thus, the company will only compensate or repair the product under a given conditions. Moreover, the use of such words as 'limited warranty' also implies that the warranty is limited in terms of time. That is, the warranty is only valid during

the defined period of time which is determined by the company. Yet, not all of the titles include the word 'warranty'; some of them use the word 'guarantee'. Basically, both words, 'warranty' and 'guarantee', mean the same thing hence they serve to protect the consumer's rights. Taking into account the consumer's law, the words have different meanings. Thus, according to Murthy and Blischke (2006) warranty is:

a written and/or oral manufacturer's assurance to a buyer that a product or service is or shall be as represented. It may be considered to be a contractual agreement between buyer and manufacturer (or seller). It specifies product performance, buyer responsibilities, and what the warrantor will do if an item purchased fails to meet the stated performance. Murthy and Blischke (2006:36)

Following this definition, warranty refers to the contract between the company and the buyer to ensure the good condition of the product. It also entails, on one hand, the responsibility of the company in case of product defect. On the other hand, guarantee is defined as "a pledge or assurance of something; a warranty is a particular type of guarantee, namely a guarantee concerning goods or services provided by a seller to a buyer" (ibid). In other words, a guarantee is an assurance provided by the company about the quality of the product. In this sense, warranty can be considered as a guarantee that the product is as good as described. Moreover, a warranty may cover different problems in case of repair during a long period of time. Guarantee is only meant for a short period of time and including only a small range of problems that can be repaired.

Knowing the difference between these two terms, namely warranty and guarantee, is very important to the reader/user. He has to know that they are not just synonymous words that can be used interchangeably. Thus, this assumption may make him lose his rights as repair of the product or having his money back; the use of such words is not just a matter of word choice, but it is the nature of the contract between the consumer and the manufacturer that determines such use. Following the titles, the

reader/user can clearly know which one is meant, a warranty or a guarantee. In addition, the period of time during which the warranty/guarantee is effective can also be stated in the titles, which is the case for (3). In this case, (3), the period of time is precisely stated as 'one year'. Some titles, however, do not include the exact period of time but still show the use of the word 'limited'. Thus, using such word is to convey to the reader/user the restriction of the warranty. That is, the warranty does not extend to a long period of time. It is, generally, limited to one year.

In terms of vocabulary type, the analysed titles are mainly based on the use of nouns. Unlike other titles, they do not involve the use of gerund that expresses generally a process. Instead, they use adjectives along with nouns. Since there is a need to explain the nature of the warranty or guarantee, adjectives are combined with nouns to achieve such purpose, as the case of (9). However, some titles include only nouns in their constructions. For instance, consider (2), (4) and (6). In fact, these titles do not include the word 'warranty'; they instead use 'guarantee' or other words as 'end-user licence'. Unlikely, title (1) uses the word 'warranty' but still it does not have an adjective as 'limited' in the other titles. This implies that the title does not present the same kind of warranty as the others. That is, it is not limited but an open one. With reference to the manual of the product, the validity of such warranty extends to five years.

Although titles provide valuable information to the reader/user, the details about the terms included and agreed by the two parts of the contract, namely the manufacturer and the consumer are clearly explained in the information provided by the warranty/guarantee. Here, it is worth considering the way in which such information are presented or conveyed to the reader/user. To achieve such purpose, the information is analysed in terms of sentence type and their frequency of use. Therefore, the following

table provides the results of analysing warranty/guarantee information represented through 210 sentences.

	Sentence type	frequency	Number of sentences
1	Imperative	3	23
	Declarative	19	
	Conditional	1	
2	Imperative	1	26
	Declarative	23	
	interrogative	2	
3	Imperative	2	13
	Declarative	10	
	Conditional	1	
4	Imperative	0	2
	Declarative	0	
	Conditional	2	
5	Imperative	1	22
	Declarative	20	
	Conditional	1	
6	Imperative	1	55
	Declarative	51	
	Conditional	3	
7	Imperative	1	13
	Declarative	11	
	Conditional	1	
8	Imperative	0	31
	Declarative	31	
	Conditional	0	
9	Imperative	4	25
	Declarative	15	
	Conditional	1	
	Interrogative	5	
Total of each type	Imperative	13	210
	Declarative	180	
	Conditional	10	
	interrogative	7	

Table 24. Sentence types used in warranty

The analysis reveals that the information provided by the warranty/guarantee is expressed through the use of variety of sentences including imperative, declarative, conditional and interrogative. As shown in the table, they vary in terms of frequency from one manual to another. However, the most used sentence types in each manual are

the declarative sentences: they represent 108 of sentences extracted from the nine manuals. In fact, such frequency is to be expected considering the type of information involved. Since the information provided in the warranty/guarantee is purely descriptive, the use of declarative sentence is very significant. That is, such type of sentence conveys the explanation of the terms of the warranty/guarantee, which include the consumer rights and the company liability.

The use of the other types of sentences as imperative, conditional and interrogative is quite possible in such type of information. Although warranty/guarantee is not mainly about giving orders to the reader/user, the imperative sentence show its presence through 13 instances of use. At first, such type seems to be irrelevant for this kind of information; however, imperatives are used to tell the reader/user what to do or whom to contact in case of product defect. Following such instructions is very important to the reader/user because ignoring them may cost him to lose his rights in terms of refund or repair. Therefore, the best way to convey such importance is through the use of the imperative sentences.

Since the warrant/guarantee is to ensure the good performance of the product and to protect the consumer rights of repair or refund, it includes a set of conditions under which these terms are fulfilled. Explaining such conditions to the reader/user is realised through the use of conditional sentences. Their frequency, in the analysed information of warranty/guarantee, is marked with 10 occurrences. However, warranty/guarantee in some manual tends to be represented through other sentence types as the interrogative sentence. That is, instead of a straightforward description, interrogative sentences are used as question and answer method to clarify, to the reader/user, the terms of warranty/guarantee. In fact, the manuals used such this method

is identified in only two manuals, which limit the use of interrogative sentences to only 7 occurrences.

Knowing that warranty/guarantee is a description of terms between the consumer and the company, the vocabulary used to convey such information may include different set of words with relation to the consumer's law. If the reader/user is not aware of such terms, it may affect his ability to understand the warranty/guarantee terms. Therefore, in order to know whether warranty/guarantee information meet the needs of the reader/user in terms of vocabulary, it is helpful to submit such information to vocabulary profiler. Effectively, it can identify different words categories that give a clear image about the nature of the vocabulary used in warranty/guarantee information. The categories identified by the profiler include common English words, academic words and technical words. With that being said, the following table provides the results of the vocabulary profiler.

	<u>Families</u>	<u>Types</u>	<u>Tokens</u>	<u>Percent</u>
K1 Words (1-1000):	299	440	3579	69.52%
Function:	(2251)	(43.73%)
Content:	(1328)	(25.80%)
> Anglo-Sax	(335)	(6.51%)
=Not Greco-Lat/Fr Cog:		
K2 Words (1001-2000):	79	119	330	6.41%
> Anglo-Sax:	(48)	(0.93%)
1k+2k		(75.93%)
AWL Words (academic):	129	180	475	9.23%
> Anglo-Sax:	(49)	(0.95%)
Off-List Words:	<u>?</u>	<u>273</u>	<u>764</u>	<u>14.84%</u>
	507+?	1012	5148	100%

Table 25. Vocabulary profiler of warranty/guarantee information

The table gives a clear image about the nature of the vocabulary involved in the structures of warranty/guarantee terms. Considering the first category of words, the profiler shows that 75.93% of the vocabulary is common words. More particularly, the

75.93% representing the common words is composed of 69.52% from the first range (K1) and 6.41% from the second range (K2). In addition to that, 69.52% of the common words, in (K1), are made up of function and content words. Respectively, they represent 43.73% and 25.80 of the vocabulary used in writing the warranty/guarantee. Knowing that, the table (25) shows that there is also a use of academic words. Thus, 9.23% of the analysed vocabulary is academic words. Their appearance is expected due to the nature of information, which is mainly based on the consumer law. In addition, there are words not identified by the profiler. Hence they are not in the common English words nor in the academic ones, they are considered as Off-list words. In fact, such words are meant to represent the technical words used in the warranty/guarantee information. As mentioned earlier these may be the unfamiliar words to the reader/user. They represent 14.48% of the vocabulary. However, taking into account that 75.93% of the vocabulary is common words, the reader/user is not likely to find any difficulty to grasp the intended meaning of the warranty/guarantee. Furthermore, since the purpose of the warranty is to satisfy the consumer by protecting the right of repair or refund, the vocabulary used to explain such information is more likely to be achieved using the common words that the reader/user is already familiar with.

In addition, warranty/guarantee appears generally with another piece of information that is service information. Such information provides how the reader/user can reach the service of the company in case there is a problem in the product. Since service information is presented with warranty/guarantee, it does not include titles to be considered in the analysis. Therefore, the sentences used to present such information are analysed first.

1. CUSTOMER ASSISTANCE INFORMATION:
2. Service
3. IF YOU NEED ASSISTANCE OR SERVICE:
4. To obtain warranty service, please contact SAMSUNG at:
5. IF YOU NEED SERVICE
6. QUESTIONS OR COMMENTS?
7. CUSTOMER INTERACTIVE CENTER NUMBERS
8. TO CONTACT LG ELECTRONICS BY MAIL:
9. Who to contact for service?

These are the introductory sentences or phrases used to introduce service information to the reader/user. Clearly, they use a variety of constructions. Thus, some of them are just group of nouns; others are clauses or even an interrogative form. In spite of that, sentence types can be still identified. That is, among the identified introductory sentences or phrase, there is the use of imperative sentence introduced with the use of infinitive clause that is the case for (4). In addition, they also include conditional clause as in (3) and (5). Interrogative sentence in this case is represented through instance (9). However, sometimes such information is introduced using a single word as in the case of (2). Hence it cannot be considered as a sentence, it is used in a form of title. In fact, in the case of (2) much information is provided under the heading service. Unlikely, the other cases where there is the use of introductory sentences or phrase the only information provided includes numbers of phones and faxes, service centre location and, sometimes, electronic addresses as emails and web sites.

5.2. Linguistic features of moves in service manuals

5.2.1. Read the manual before servicing the product

1. BEFORE SERVICING THE UNIT, READ THE "SAFETY PRECAUTIONS" IN THIS MANUAL.
2. READ THIS MANUAL CAREFULLY TO DIAGNOSE TROUBLE CORRECTLY BEFORE OFFERING SERVICE.
3. BEFORE SERVICING THE CHASSIS, READ THE SAFETY PRECAUTIONS IN THIS MANUAL.
4. BEFORE OFFERING SERVICE, READ THIS MANUAL CAREFULLY TO DIAGNOSE TROUBLES CORRECTLY.
5. BEFORE SERVICING THE UNIT, READ THE SAFETY PRECAUTIONS IN THIS MANUAL.
6. BEFORE SERVICING THE UNIT, PLEASE READ THIS MANUAL CAREFULLY FOR SAFETY AND CORRECT SERVICES.
7. Please read this manual before making any adjustments.

The above sentences are extracted from service manuals of household equipment. They represent the first identified move that ask the technician to read the manual carefully before servicing the product. However, this move is not used in all the analysed manuals. Thus, there are only seven instances of such move out of 15 analysed service manuals. Since the manuals are very important to guide the technician, the manuals notify him through the use of the word 'caution'. The use of such word is to attract the attention of the reader/technician that the presented piece of information is a very important one. Thus, in order to make sure that the technician reads the information it is placed right at the beginning of the manuals. In addition, 'caution' is not the only word used to draw the technician's attention; there are other possible words as 'note', which is the case for (7). However, the use of 'caution' is more likely to catch the attention of the technician hence it is generally associated with danger. The information provided after 'caution' is mainly expressed through the imperative sentences. The use of imperative implies that the technician has no choice but to follow the instructions. In addition, it determines which action the technician needs to perform first. That is, the sentences, in fact, express two actions namely 'reading' and

‘servicing’. The reading of the manuals is to be performed first hence without which servicing the product may be difficult. Furthermore, the sentences that include the adverbial clause ‘before’, place the main clause, which includes the imperative, at the end. In other words, ‘before clause’ is presented first to the reader/technician followed by the imperative one. In fact, it is used first to warn the technician not to service the product without reading the manual. It seems that most of the instances identified in the manuals use such method of placing important information first. To give it substance, out of 7 instances, there are 5 sentences that use ‘before clause’ at the beginning of the sentence. However, there is a case where the imperative clause is used first, namely the case of (2). In this case, the ‘to + infinitive’ is used to state the purpose of the action which is reading the manual. Although reading is conveyed through the imperative, there is the use of ‘please’ in some sentences. Using such word in the imperative sentence makes it look like an appeal rather than an order. Hence being more direct is less polite, some manuals use such method to show politeness towards the reader/technician. Such consideration makes the reader/technician more likely to respond to the request.

On the other hand, some of the sentences include very specific request as to read safety precautions; as opposed to others that ask to read the manual. Hence the safety precautions are very important to both the technician and the product they are explicitly stated to make sure the technician gives them more priority while servicing the product. Knowing that, in some sentences there is a preference to express them implicitly using the word ‘carefully’. Since the technician is asked to read the manual the word ‘carefully’ makes him pay more attention to such information as safety precautions. Therefore, such word does not appear in sentences stressing safety precautions. Moreover, another precision is worth noting in the sentences. This time it is about the

manual. In fact, the manual is precisely indicated in the sentence using the demonstrative pronoun ‘this’. The use of such pronoun is to convey to the reader/technician that he has to use the service manual of the product and not another manual that may describe a similar product.

Moreover, the product is referred to using a variety of words including ‘unit’ and ‘chassis’. Although they refer to the same product at hand, there is a subtle difference. In fact, the word ‘unit’ in such use refers to the product as a whole while the use of the word ‘chassis’ is to refer mainly to the frame on which the product is build. This implies, in fact, the process of disassembling the product when repair is needed.

Furthermore, the process of servicing the product includes different steps that are clearly conveyed through the use of gerund. Thus, most of the cases where the word ‘service is used, it is presented in –ing form. As mentioned earlier, taking such process must be after reading the manual. In fact, most of the sentences ask the technician to read the manual before getting involved in servicing the product. However, only a few of them include the main purpose of reading which is ‘to diagnose troubles correctly’. So, reading the manual for the technician is not to ensure his safety but also to help him to identify the source of the problem correctly. Thus, unless the problem is determined the product cannot be fixed appropriately.

With that being said, the patterns used to construct such sentences can be represented as follows:

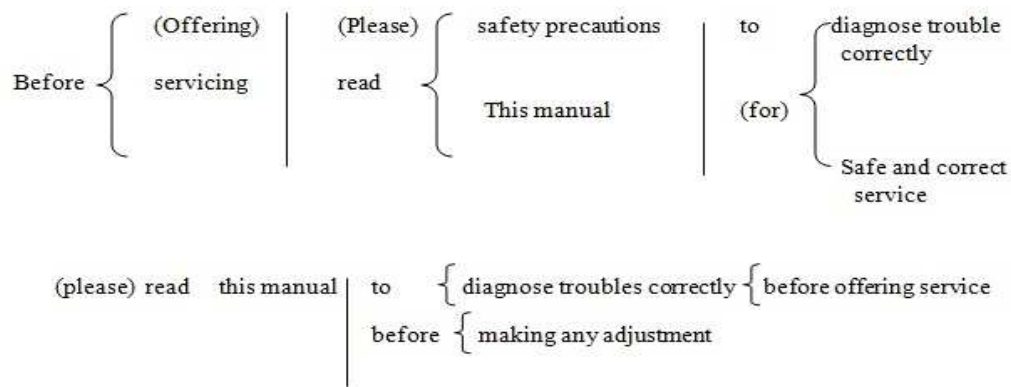

Figure 23. Patterns used to express 'read and keep' move in service manuals

These two patterns represent how the information, provided by the sentences, are organised. Thus, the first pattern shows the use of 'before clause' at the beginning of the sentence. The word 'before' here is used to indicate the order of the actions to be performed. Although the main action of the technician is to service, the product there is another one to be accomplished first namely the reading of the manual. In this pattern, the two actions are separated using a vertical line. On the one hand, the servicing of the product is expressed using a gerund. However, sometimes it is used as noun 'service' by adding another word as 'offering' in gerund form, which is provided in parenthesis in the pattern. The action of reading, which is the first step to be taken by the technician, is expressed through the imperative. Expectedly, the information provided next is to tell the technician what to read. In this case, it is either the safety precautions or the manual. However, this information provided using such pattern is not restricted to what to read but also why to read it. Thus, the purpose of such action is expressed through the use of the prepositions 'to' or 'for'. That is, the purpose of reading the manual is to diagnose trouble or for safe and correct service.

The second identified pattern, on the other hand, uses the imperative right at the beginning of the sentence. Unlike the first pattern, what to read does not involve safety

precautions but only ‘this manual’. In addition, the second part of the sentence uses a variety of constructions. One of these constructions is to place the purpose of reading just after the imperative and leave ‘before clause’ to the end of the sentence. The other construction, however; uses ‘before clause’ right after the imperative form. This consideration makes it the opposite of the first pattern which starts with ‘before clause’. Although there are two possible patterns in the construction of sentences, the first pattern tend to be the most used one for such sentences.

Since these manuals are primary devoted for technicians, it is worth analysing the vocabulary used to produce such sentences. The vocabulary profiler is used to identify the nature of such vocabulary. The use of such program is very useful hence it can identify different categories of words including common words, academic words and technical words. The results obtained from the profiler are presented in the following table.

	<u>Families</u>	<u>Types</u>	<u>Tokens</u>	<u>Percent</u>
K1 Words (1-1000):	17	20	60	77.92%
Function:	(29)	(37.66%)
Content:	(31)	(40.26%)
> Anglo-Sax =Not Greco-Lat/Fr Cog:	(4)	(5.19%)
K2 Words (1001-2000):	1	2	3	3.90%
> Anglo-Sax:	()	(0.00%)
1k+2k		(81.82%)
AWL Words (academic):	2	2	8	10.39%
> Anglo-Sax:	()	(0.00%)
Off-List Words:	<u>?</u>	<u>3</u>	<u>6</u>	<u>7.79%</u>
	20+?	27	77	100%

Table 26. Vocabulary profiler for sentences used as first move in service manuals

The table shows the different categories involved in the constructions of the vocabulary used in the sentences. The first category to be identified by the profiler is the

common English words referred to as K1 and K2. The two ranges of this category include words that are common in English. Thus, the vocabulary used in the construction of the discussed sentences represents 77.92% of the first range of the common words i.e. K1. The vocabulary from the second range K2 appears in the sentences as 3.90%. Knowing that, the overall use of the English common words is revealed by combining K1 and K2. As shown in the table the sentences, in fact, involve 81.82% of the vocabulary that belongs to English common words. Although English common words involve two ranges, most of the words used in the sentences belong primarily to the first range K1. In turn, the 77.92% of the first range is based mainly on two sub-categories namely function and content words. While function words represent 37.66% of the K1, content words, on the other hand, represents 40.26%. This means that there is more use of content words than the function ones in the construction of the sentences. In addition, the vocabulary entails 10.39% of the words belonging to academic words. However, some of the words are considered as Off-list words. These words are in fact the technical words used in the sentences. Since they are not recognised as common or academic words the profiler put them in the Off-list words. The use of such words in the sentences, as shown by the table, represents 7.79% of the analysed vocabulary. Although the manuals are to address the technicians, technical words are less used in these sentences in comparison to other categories as academic words for instance.

5.2.2. Safety instructions or precautions

1. SAFETY PRECAUTIONS
2. Precautions
3. IMPORTANT SAFETY NOTICE
4. SAFETY
5. SAFETY PRECAUTIONS
6. Safety Instructions on Service
7. IMPORTANT SAFETY NOTICE!
8. SAFETY CHECK-OUT
9. SAFETY PRECAUTIONS
10. IMPORTANT SAFETY NOTICE
11. Safety instructions
12. Safety Precautions

Analysing the service manuals reveals that there are different titles used to indicate information about safety. Thus, regardless of the words used in the titles, all of them include the word 'safety'. Whether they are presented as instructions or precautions, they both seek the safety of the technician and the product as well.

Although the words used to describe the word safety are to be 'instructions', 'precautions' and 'notice', it seems that the word 'safety' can be used alone as a title as in the case of (4). Using such title is less confusing in the sense that it is not accompanied with such words as 'instructions' or 'precautions'. Following such way of presenting titles makes it concise and precise to the reader/technician. In fact, there are eleven cases, out of the twelve titles, in which the word 'safety' appears. Apart from case (4), the word is used in combination with other words. To make it clear, the word 'precautions' appears five times in the presented titles, four of which are used with the word 'safety'. There is one case where 'precautions' appear alone as a title, clearly shown in case of (2). The word 'instructions' shows two occurrences both of them with the word 'safety' whereas the word 'notice' is identified through three instances each of which include the word 'safety'. Other words are also possible to be used with 'safety'

such as 'check-out', which appears in (8). Therefore, taking into consideration all the instances of 'safety', there is a variety of words to be used with such a word.

The co-occurrences of the word safety with other words are as follows, from the most to less frequent words, 'safety precautions', 'safety notice', 'safety instructions' and 'safety checkout'. However, in the case of 'safety notice', there is an interference of another word which is 'important'. In fact, the use of such word is very significant to draw the attention of the reader/technician. Without which, reader/technician may ignore such notice. The reason behind this is due to the impact the word leaves on the reader/technician. Thus, using the word 'notice' may be understood as the information to be presented is less important. That is, it does not have the same effect as the word 'precautions', which gives the reader/technician the impression of dealing with dangerous situations. As a result, the word 'important' is not needed with 'precautions' which is strong enough to make the reader/user consider the information being presented with a lot of care. However, 'notice' needs the word 'important' to show the importance of the information.

In addition, the words used to constructs the titles are mostly nouns. Thus, the gerund is not used in such titles due to the nature of information being described. That is, the information, in fact, includes what to be done and what to avoid on the part of the technicians. So, there is not any process involved which is generally best conveyed through the use of gerund. Although they are mostly used, nouns are not the only ones to appear in the titles hence, as mentioned earlier, there is also a use of adjectives. They are used to describe nouns so that to make them more specific. For instance, the adjective 'important', as mentioned before, is to specify that the 'notice' meant in the titles is not a simple safety notice but an important one that needs more consideration by the reader/technician.

The importance of safety is not only shown through the titles that catch the reader/technician attention but also through the use of sentences that convey the intended information. In order to understand how such information are presented to the reader/technician, safety information are analysed in terms of sentence types i.e. the type of sentences through which the safety information is conveyed. In addition, considering safety information in such a way helps to identify the prominent sentence type used to communicate safety to the technician. The following table shows the sentence types identified in safety instructions. In addition, it gives the frequency of each type as it provides the number of sentences used to represent safety instructions in each manual. However, it is worth noting that the data represented in the table refer to twelve analysed manuals hence there are three manuals that do not involve safety instructions.

	Sentences type	frequency	Number of sentences
1	Imperative	20	41
	Declarative	18	
	Conditional	3	
2	Imperative	12	16
	Declarative	4	
	Conditional	0	
3	Imperative	8	15
	Declarative	3	
	Conditional	4	
4	Imperative	4	16
	Declarative	12	
	Conditional	0	
5	Imperative	89	126
	Declarative	29	
	Conditional	8	
6	Imperative	18	25
	Declarative	3	
	Conditional	4	
7	Imperative	2	5
	Declarative	3	
	Conditional	0	

8	Imperative	13	27
	Declarative	12	
	Conditional	2	
9	Imperative	5	11
	Declarative	6	
	Conditional	0	
10	Imperative	2	5
	Declarative	3	
	Conditional	0	
11	Imperative	27	52
	Declarative	18	
	Conditional	7	
12	Imperative	13	19
	Declarative	6	
	Conditional	0	
Total of each type	Imperative	213	358
	Declarative	117	
	Conditional	28	

Table 27. Sentence types in safety instructions of service manuals

The table shows the sentence type used in safety instructions, extracted from twelve service manuals; there are 358 sentences used to convey such information to the technician. Depending on the manual, the number of sentences used differs from one manual to another. Thus, in some manuals the safety instructions is expressed by only five sentences while in others they are expressed by 126 sentences. The main sentence types identified in safety instructions, as shown in the table, include imperative, declarative and conditional. Clearly, the imperative is the most frequent one among the three identified types. Its prominence of use is determined through the use of 213 sentences.

Thus, the overwhelming use of the imperative shows how important safety instructions are. Since the safety of the technician and the product are involved such information cannot be expressed softly. To ensure that the technician is to follow safety instructions they are expressed through the imperative. It tells him clearly what to do and what to avoid in order to ensure his safety. The actions that must be done by the

technician are expressed by the imperative while the actions to avoid are conveyed through the negative imperative.

Declarative sentences show their presence in the safety instructions through 117 sentences. They have a significant role to play in conveying safety information. To make sure that the technician understood the instructions assuring his safety, declarative sentences are used to give him additional information that helps him perform the assigned tasks safely. Thus, while the imperative is used to give direct instructions, declaratives explain why he has to perform such tasks.

In case the technician faces a difficult situation, conditional sentences provide him with the necessary information that helps him. Hence such situations are not likely to happen unless there is a presence of some conditions, the conditional sentences namely using 'if' gives him possibility of occurrences and what to do accordingly. Their pattern is more likely to be expressed as "if this happens, do this and that". It seems that the use of conditionals in safety instructions, of the analysed service manuals, is represented by 28 sentences. Being less frequent does not mean they are less significant; instead, such frequency implies how infrequent the situations that involve a threat to the technician or the product are.

However, knowing sentence type and being able to understand the sentence itself are two different things. Therefore, unless the reader/technician is familiar with the vocabulary used to build such sentences, he will face some difficulties in understanding the intended meaning of the sentences. Knowing most of the vocabulary ensures a better understanding of the sentences. As a result, vocabulary profiler is used to know the nature of the vocabulary used in safety instructions of service manuals. It is able to identify different categories of words including common words, academic words

and technical words, which gives a clear image about the vocabulary used in safety instructions. The following table represents the results gained from the vocabulary profiler.

	<u>Families</u>	<u>Types</u>	<u>Tokens</u>	<u>Percent</u>
K1 Words (1-1000):	337	467	2821	67.25%
Function:	(1711)	(40.79%)
Content:	(1110)	(26.46%)
> Anglo-Sax	(388)	(9.25%)
=Not Greco-Lat/Fr Cog:		
K2 Words (1001-2000):	130	184	488	11.63%
> Anglo-Sax:	(171)	(4.08%)
1k+2k		(78.88%)
AWL Words (academic):	94	131	286	6.82%
> Anglo-Sax:	(18)	(0.43%)
Off-List Words:	<u>?</u>	<u>283</u>	<u>600</u>	<u>14.30%</u>
	561+?	1063	4195	100%

Table 28. Vocabulary profiler of safety instructions in service manuals

The vocabulary of safety instructions, as presented in the table, includes different categories of words used to convey information to the technician. The first identified category is that of common English words. It includes two ranges. The first range (K1) of words represents 67.25% while the second range (K2) covers 11.63% of the vocabulary. Taking into account (K1) and (K2), English common words represent 78.88% of the vocabulary used in safety instructions. In addition, the first range (K1), as shown in the table, consists of function and content words that represent 40.79% and 26.46% respectively. The table also shows that the use of academic words represents 6.82% in the vocabulary of safety instructions. However, some of the words are identified as Off-list words; such category of words refers mainly to technical words. Although their appearance is to be expected in service manuals, they represent a small

portion of the vocabulary as they represent 14.30% of the safety instructions' vocabulary. With that being said, the technician is more likely to understand clearly all the words used in safety instructions because they mostly include common words and less technical ones.

5.2.3. Specifications

1. SPECIFICATIONS
2. Product Specifications
3. SPECIFICATIONS
4. S P E C I F I C A T I O N S
5. TECHNICAL INFORMATION
6. TECHNICAL INFORMATION
7. SPECIFICATIONS
8. Specifications
9. SPECIFICATIONS
10. SPECIFICATIONS
11. SPECIFICATIONS
12. SPECIFICATIONS
13. SPECIFICATIONS
14. Specifications

These are the titles used to indicate specifications in the service manuals. They provide the technician with information about the product being inspected to help him determine whether the product meets the defined requirements or not. Generally, specifications are referred to using an abbreviation as 'spec'. Thus, a product that fails to fulfil the specified requirements is known as 'out of spec'. If it is the case, such information is also beneficial for the product's owner who can claim for product replacement or refund as specified in the terms of the warranty. Hence, it is worth considering how such information is presented to the technician.

First, titles are used to signal the place of such information so that they can be spotted easily. Although, there are a variety of manuals, most of the identified titles are constructed using one word. Only three titles involve two words in their constructions. However, among these three, two of them, namely (5) and (6), do not use the word

'specifications' at all. In the case (2) the word is used with another one. So this makes the word 'specifications' appear in twelve of the titles presented above. Although, it is mostly used in the titles, some manuals show a possibility of using different words as 'technical information'. This assumption is clearly shown in the instances of (5) and (6). As a result, in terms of structure, titles for these manuals tend to be of two types: one-word title or two-word title. The 'one word title', namely using 'specifications', seems to be more precise and concise than the other type that use two words as in 'product specifications' and 'technical information'. In fact, the number of words in this case is not an accurate criterion for precision.

Although using one word in the title makes it concise but it may not be precise enough, particularly in the case of specifications. Why so? Because the word 'specifications' may be misleading hence there are many types of specifications. These are performance specifications and technical specifications. In turn, technical specifications include three sub categories namely individual unit specifications, acceptable quality level specifications and distribution specifications (Gitlow 1989). Taking this into consideration, it is worth to shed some light on the two broad categories that are performance specifications and technical specifications. The former refers to consumer needs in terms of product performance. For instance, a computer facility requires temperature between 18 and 21 C°, the company must provide an air conditioner that meets the stated requirements for the consumer. The latter describes the performance of the product when it is delivered. Thus, the consumer/technician has to make sure whether the product fulfils the requirements he asked for or not. With that being said, 'specifications' expressed in the titles is more likely to refer to the second type i.e. technical specifications. This consideration is supported by the fact that there are other words used to indicate specifications of the product namely 'technical

information’. So as not to leave room for ambiguity that may rise from using the word ‘specifications’, some manuals may prefer to use ‘technical information’ instead in order to give more precision about the nature of the information being presented.

As mentioned above, the titles are constructed using one-word or two-word patterns. Considering the type of words being used, nouns tend to be the most frequent type. However, some other types are used, as in the case of (5) and (6), in order to provide more clarity to the title. So, in the instance of ‘technical information’, there is a use of an adjective along with the noun ‘information’ to give a clear image about the nature of information being provided, in this case it is not any information but a ‘technical’ one. Unlike other types of information, specifications are generally provided in tables. Since they include technical information about the product, they are not expressed through the use of sentences but rather through words. Each of the words used correspond to the nature of information being presented. Therefore, to understand the nature of the words used in the table that convey specifications, the latter is submitted to the vocabulary profiler. It is very helpful to determine the category of words used in the specifications and convey such information to the technician. The results provided by the profiler are shown in the following table.

	<u>Families</u>	<u>Types</u>	<u>Tokens</u>	<u>Percent</u>
K1 Words (1-1000):	196	227	1365	53.57%
Function:	(211)	(8.28%)
Content:	(1154)	(45.29%)
> Anglo-Sax =Not Greco-Lat/Fr Cog:	(174)	(6.83%)
K2 Words (1001-2000):	71	80	179	7.03%
> Anglo-Sax:	(76)	(2.98%)
1k+2k		(60.60%)
AWL Words (academic):	60	67	189	7.42%
> Anglo-Sax:	(18)	(0.71%)
Off-List Words:	<u>?</u>	<u>370</u>	<u>815</u>	<u>31.99%</u>
	327+?	743	2548	100%

Table 29. vocabulary profiler of specifications in service manuals

The table provides the different categories involved in the constructions of the vocabulary of specifications. The profiler can identify three categories including English common words, academic words and technical words. Thus, the words used from the first category of English common words represent 60.60% of specifications vocabulary. Hence English common words are divided into two ranges of words namely K1 and K2, the mentioned percentage refers to both rangers together. More particularly, the words used from K1 represent 53.57% while those used from K2 represent only 7.03% of the vocabulary. Moreover, K1 tend to be based on other sub-categories shown in the table as function and content words. To put it differently, 53.57% of the words belonging to the first range are, in fact, composed of 8.28% of function words and 45.29% of content ones. Therefore, the first range of words that appears in the vocabulary includes more content words than the function ones. The reason behind this is due to the nature of the information that requires the use of words rather than sentences, which usually make use of function words. However, the fact that there is a presence of function words means that there is a presence of few sentences. Some manuals include such sentences to give more information to the technician or to explain

some of the information presented in the table of specifications. Apart from common words, 7.42% of the words building the vocabulary of specifications belong to the academic words. Additionally, the vocabulary includes other category of words identified in the profiler as Off-list words. In fact, these words represent the technical words used in specifications. Knowing that, 31.99% of the words in specifications are to be technical ones. Although there are more common words than technical words, readers/users, rather than the technician, are not likely to understand specifications. Thus, he is the only one who can interpret the presented information because he shares the conventions used to represent such information. In fact, these conventions are part of his background knowledge. In addition, the use of common words is to designate such items of the product as dimension, performance, capacity, etc.

5.2.4. Audience of the manual

Some manuals prefer to specify clearly to whom the manual is supposed to address. Therefore, the audience of these manuals is restricted to qualified people namely the technicians who are supposed to service the product. In addition, specifying the audience is to warn unqualified people, such as the owner of the product, not to service the product himself. Thus, in order to show the importance of this piece of information, sometimes, it is presented in safety precautions. By doing so, the company conveys that it is not to take any responsibility if the product is to be serviced by others than the technician. Therefore, it is worth considering how this information is presented to the reader/user(in this case technician), and what type of sentences is used to convey their intended meaning. The following are the sentences used in the service manual to indicate the nature of the audience the manuals are devoted to.

1. This service information is intended for individuals possessing adequate backgrounds of electrical, electronic and mechanical experience.
2. THE OVEN IS TO BE SERVICED ONLY BY PROPERLY QUALIFIED SERVICE PERSONNEL.
3. This service information is intended for individuals possessing adequate backgrounds of electrical, electronic and mechanical experience.
4. Operators of the equipment must ensure that all installation, service and as well as all inspections, are performed by authorized and qualified personnel.
5. The following information will instruct service professionals on the function, proper diagnosis and repair of water heaters employing the Bradford White DEFENDER Safety System .
6. The information in this service guide is intended for use by individuals possessing adequate backgrounds of electrical, electronic, and mechanical experience.

The sentences presented above are extracted from service manuals of household's equipment. Since not all the manuals include information about the type of the audience, the provided sentences refer only to six of them. It is worth noting that the declarative sentences tend to be the only used sentence type in the six extracted sentences. The information is expressed directly and explicitly conveyed to reader so that to leave no room for ambiguity. However, there are cases where the intended information is expressed rather indirectly as in the case of (2) and (4) since they state that the installation or repairing of the product must only be performed by a qualified person; they clearly imply that the information presented in the service manual is only meant for the technician as a qualified person because he is the one who does the installation and repairs. Unlike (2) and (4), the other instances meant to define the audience of the manual state clearly and directly that the service information is only intended for qualified individuals.

Moreover, the six above instances have a common feature, which is giving more attention to the doer of the action; in this case the technician. This is achieved mainly by the use of the passive voice. Thus, except from case (5), which uses the active voice, there are five instances that use passive voice to stress that the information is meant for qualified persons. Although the use of active voice is more straightforward, the use of the passive voice in these sentences is to specify the person to service or to read the service information, which is indicated clearly through the use of 'by' or 'for'; generally used in the passive voice to show the agent of the sentence.

Furthermore, the choice of words used to describe the target audience of the service manuals differ from one manual to another. The words used for such purpose tend to be of four patterns, considering two sentences show the same pattern, including 'individuals possessing adequate backgrounds...', 'qualified service personnel', 'authorized and qualified personnel' and 'service professionals'. The amount of information given to describe the technician in each pattern varies in the manuals. The first pattern 'individuals possessing...' as shown in (1), (3), and (6) tends to give a detailed description of the intended technician. It points to the qualities that have to be acquired by the technician, which entail the adequate background knowledge in electricity, electronics and mechanics. The second pattern, namely 'qualified service personnel', that appears in (2), does not involve details as the first one but rather it mentions proper qualifications as general description of the intended technician. The third one, on the other hand, adds another criterion to the qualifications. Thus, the technician has to be not only qualified but also 'authorized' person to service the product. Unlikely, the fourth pattern tends to use fewer words than the previous ones. It refers to the intended technicians as 'service professionals'. The term 'professionals' describes precisely and concisely the intended technician for servicing the product.

Thus, there is no need to include any details in the description; hence, the term includes all the qualities required like education, training, skills, and experience. The sentences used to convey the description of the intended technician-audience of the manual-are presented in the following table.

Types of information in the first part of the sentence		Expressed through	Type of information in the second part of the sentence	Expressed through
P1	Service information	This service information	Qualified person namely the technician	Individual possessing adequate background knowledge
P2	product	The oven		Properly qualified personnel
P3	users	Operators of equipment		Authorized and qualified personnel

Table 30. Sentences' structure defining manuals audience

The table shows clearly three parts of the sentences, discussed previously, each part of the sentences is realised using different patterns indicated as 'P'. The first pattern includes service information as in the case of (1), (3), (5) and (6), is expressed clearly through "this service information". The second pattern starts with the product type, in this case an oven, as in (2). The third pattern starts with the users of the product referred to as "operators of equipment". Although the sentences present different types of information in the first part, they all have the same type of information in the second one. That is, they all describe the qualified person concerned with the presented information: the technician.

As the word choice is very important to ensure that the sentences convey exactly the intended meaning, the structure of these sentences leads to consider the vocabulary used to construct them. As mentioned earlier, some manuals used more words than others to describe the audience or the intended technician to whom the

manual is addressed. Therefore, the vocabulary is analysed using the vocabulary profiler and presented in the following table.

	<u>Families</u>	<u>Types</u>	<u>Tokens</u>	<u>Percent</u>
K1 Words (1-1000):	29	34	70	62.50%
Function:	(40)	(35.71%)
Content:	(30)	(26.79%)
> Anglo-Sax =Not Greco-Lat/Fr Cog:	(10)	(8.93%)
K2 Words (1001-2000):	9	9	19	16.96%
> Anglo-Sax:	()	(0.00%)
1k+2k	(79.46%)
AWL Words (academic):	8	8	12	10.71%
> Anglo-Sax:	()	(0.00%)
Off-List Words:	<u>?</u>	<u>8</u>	<u>11</u>	<u>9.82%</u>
	46+?	59	112	100%

Table 31. Vocabulary profiler of sentences indicating manuals' audience

The table shows different categories of words involved in the construction of the sentences. They include English common words, academic words and technical words. The first category of English common words has two ranges of words shown as K1 and K2 that represent 79.46% of the vocabulary. More particularly, 62.50% belong to the first range K1 and 16.96% to the second range K2. In turn, K1 comprises two categories of words, namely function and content words. Therefore, 62.50% of the K1 consists of 35.71% of function words and 26.79% of content words. Knowing that, academic words show a significant appearance of 10.71% in the vocabulary because most of them include a description of the qualities to be fulfilled by the intended technician. Moreover, technical words represent 9.82% of the words used in the sentences; they are indicated in the table as Off-list words because the profiler cannot identify them in the category of common words or in the academic ones.

5.2.5. Product description/features

1. FEATURES & TECHNICAL EXPLANATION
2. INTRODUCTION
3. FEATURES & TECHNICAL EXPLANATION
4. ADVANTAGE S OF THIS PRODUC T
5. Introduction
6. FEATURES AND LOOK
7. Mechanical description
8. PRODUCT INFORMATION
9. Product function
10. Description

These titles, which are extracted from service manuals, are used to indicate a description of the product and its features. That is, they point out what can be accomplished by the product, its function and advantages, and the names of the different parts involved in its constructions. The information presented under such titles is of great importance to the technician as they make him more familiar with the product he is dealing with. As a part of his job, the technician is supposed to know the type of the product before making repairs. Thus, knowing such information helps him to determine the appropriate way of fixing the product.

In spite of that, the titles do not seem to present the same amount and type of information taking into account their structure and the words used to build them up. To start with, it is worth noting that these titles represent only ten service manuals hence five of them do not involve such information i.e. description of the product. Being retrieved from different manuals, they vary in the number of words used in their constructions from one single word to four words. Thus, titles with more words tend to be more specific than those with fewer ones. For instance in the case of (1) there are four words involved in the constructions of the title, while in case of (2) there is only a single word. For example, titles such as ‘features and technical explanations’ tell the reader/technician exactly what type of information is being presented. However, titles

such as 'introduction' give no clues about the information whether it is related to features or technical explanation as in (1). In like manner, the amount of information may be assumed considering the titles length; titles with more words are more likely to give more information to the reader/technician as in the case of (1) or (3). Titles with few words may just present general information without too much detail as in the case of (2).

The presented information may also depend on the nature of the product. Although the technician has an adequate training and background knowledge, this move is used to make sure that he knows the different characteristics of the product at hand. Thus, complicated equipment need a lot of description and explanations as opposed to less complicated ones, which require a general description. For instance, a refrigerator is less complicated than a tumble dryer and thus a brief description of the main features and functions will be enough to the technicians. However, in the case of tumble dryer, a detailed description is needed as the product includes many complicated components. The presentation of such information to the technician involves a careful choice of words and includes conventions that are part of technician's background knowledge. Therefore, in order to determine the nature of the vocabulary used in conveying such information, it is analysed using the vocabulary profiler; the results obtained are presented in the following table.

	<u>Families</u>	<u>Types</u>	<u>Tokens</u>	<u>Percent</u>
K1 Words (1-1000):	200	249	1169	55.32%
Function:	(692)	(32.75%)
Content:	(477)	(22.57%)
> Anglo-Sax =Not Greco-Lat/Fr Cog:	(155)	(7.34%)
K2 Words (1001-2000):	86	104	210	9.94%
> Anglo-Sax:	(117)	(5.54%)
1k+2k		(65.26%)
AWL Words (academic):	54	60	114	5.40%
> Anglo-Sax:	(3)	(0.14%)
Off-List Words:	<u>?</u>	<u>301</u>	<u>620</u>	<u>29.34%</u>
	340+?	713	2113	100%

Table 32. Vocabulary profiler of product description and features

As shown in the table (32), the categories identified by the profiler involve English common words, academic words and technical words. Thus, 65.26% of the words used to convey information about ‘product description’ belong to English common words. Knowing that English common words have two ranges namely K1 and K2, the 65.26% is a combination of 55.32% and 9.94% representing both ranges respectively. The first range of common words consists of two types of words including function and content words. The first range (55.32%) is composed of 32.75% of function words and 22.57% of content ones. On the other hand, academic words represent 5.40% of the words used in the vocabulary. The profiler does also identify technical words within the vocabulary represented by the Off-list in the table. Hence, the description of the product is to make sure that the technician familiar with its features and functions; the use of such words is required to describe the different parts of the product and to give a technical explanation if needed. Having adequate background knowledge, the technician does not have any difficulties in interpreting such words. Bearing this in

mind, the profiler shows that technical words are highly used in ‘product features and description’ hence they represent 29.34% of their vocabulary.

5.2.6. Installation instructions

1. INSTALLATION INSTRUCTIONS
2. Installation
3. INSTALLATION
4. INSTALLATION INSTRUCTIONS
5. INSTALLATION INSTRUCTIONS

The above titles are extracted from service manuals. They are used to indicate information about installation. Depending on the nature of the product, such move may not be present in the service manual. Thus, out of fifteen analysed manuals, only five of them involve such information. Although they are not present in all manuals, the technician still can do installation of the product effectively because he received adequate training as a part of his job. However, for some products, he may need to check the manual to do the installations. In addition, the appropriate installation is the first thing to be checked while servicing the product because inappropriate installation can affect the product performance. So, it is very important for the technician to be familiar with the installation of the different products.

The titles that enable the technician to access the information of the installation are constructed using one or two words. Although the word ‘installation’ is used in the five titles presented above, the word ‘instructions’ is used only three times hence two of the titles consist of a single word namely ‘installation’. Even if the word ‘installation’ stands alone as a title, it is more likely to be interpreted as ‘installation instructions’. However, using both words in a title makes it easy for the reader/technician to spot the information in the manual. Since the installation instructions vary depending on the product at hand, the sentences used to convey such information is more likely to involve

a diversity of sentence types. Therefore, the sentences are analysed in order to reveal the type of sentences used to convey the instructions of installation to the technician; they are presented in the following table.

Sentence type		frequency	Number of sentences
1	Imperative	23	26
	Declarative	2	
	Conditional	1	
2	Imperative	1	16
	Declarative	15	
	Conditional	0	
3	Imperative	18	23
	Declarative	4	
	Conditional	1	
4	Imperative	22	48
	Declarative	21	
	Conditional	5	
5	Imperative	5	11
	Declarative	5	
	Conditional	1	
6	Imperative	14	39
	Declarative	22	
	Conditional	3	
Total of each type	Imperative	83	163
	Declarative	69	
	Conditional	11	

Table 33. Sentence types of installation instructions

The installation instructions are, in fact, represented by 163 sentences extracted from six service manuals. The table sums up the main identified sentence types in the installation instructions: imperative, declarative and conditional. On the one hand, the most frequent sentence type is the imperative as it appears in 83 sentences where the information is provided to the reader/technician about installation of the product and conveyed through direct instructions using the imperative. On the other hand, the declarative sentences are present in 69 installation instructions that help the technician to understand the defined tasks. Such information are very important to the technician because they tell him why he needs to carry on the intend tasks. In addition to

imperative and declarative, the conditional sentences are to notify the technician of possible danger or problems that may face him while performing the intended tasks. As that the installation instructions are mainly conveyed through the imperative sentences, it is worth analysing the words involved in their constructions by the vocabulary profiler.

	<u>Families</u>	<u>Types</u>	<u>Tokens</u>	<u>Percent</u>
K1 Words (1-1000):	262	338	2072	67.43%
Function:	(1294)	(42.11%)
Content:	(778)	(25.32%)
> Anglo-Sax =Not Greco-Lat/Fr Cog:	(372)	(12.11%)
K2 Words (1001-2000):	90	120	285	9.27%
> Anglo-Sax:	(126)	(4.10%)
1k+2k		(76.70%)
AWL Words (academic):	60	82	195	6.35%
> Anglo-Sax:	(14)	(0.46%)
Off-List Words:	<u>?</u>	<u>185</u>	<u>521</u>	<u>16.95%</u>
	412+?	723	3073	100%

Table 34. Vocabulary profiler of installation instructions

The results obtained from the profiler indicate that there are three categories of words involved in the construction of the vocabulary including English common words, academic words and technical words. As shown in the table, the first category has two ranges namely K1 and K2. Thus, the words used from K1 represent 67.43% of the vocabulary and those used from K2 represent 9.27%. The frequency of English common words in the vocabulary of installation instructions represents 76.70%. In spite of that, there is a use of other sub-categories, which clearly appear in the first range K1. They include function and content words: 42.11% of the words are function words and 26.32% are content ones. Apart from common words, other types are also possible in the vocabulary as academic words. They represent 6.35% of the words used in

installation instructions. Moreover, the profiler identifies some of the words as Off-list words representing the technical words of the installation instructions. It seems that their presence is more significant than the academic ones hence they represent 16.95% of the overall vocabulary.

5.2.7. Operating instructions

1. OPERATING INSTRUCTIONS
2. Operating Instructions
3. Operation Function
4. OPERATING INSTRUCTIONS
5. OPERATION
6. OPERATIONAL DESCRIPTION

Although service manuals are mainly devoted to provide information about servicing the product, they also include information about operating the product. Thus, the presented titles, above, are extracted from six service manuals representing operating instructions. They are composed of one or two words that involve mainly ‘operating’ and ‘instructions’, although some of them include different words as ‘function’ and ‘description’ instead of ‘instructions’. In fact, these titles are structured in different categories of words including nouns, adjectives and gerund. On the one hand, the use of such types depends on the word at hand. Thus, the word ‘operating’ appears more frequently in gerund form rather than it appears as noun or adjective. On the other hand, the word ‘instructions’ is only used as a noun. In addition, the word ‘operating’, as a gerund, collocates with the word ‘instructions’ as in the case of (1),(2), and (4); however, when it is used as noun or even as an adjective, other words are used instead of instructions such as ‘function’ and ‘description’ as in the case of (3) and (6). Moreover, it can be used as a noun without any other words as in the case of (5).

As a result, the word ‘operating’ can appear in different forms depending on the word it collocates with. Such use of the word depends also on the intended meaning to be conveyed. Thus, using the word as a gerund ‘operating’ conveys to the reader/technician that there is a process involving different steps and actions to be performed. However, if it is to describe the operation or the function of the product itself such as the function of each part inside the product and how they work, it is more likely to be used as a noun or adjective which is the case for (3) and (6) respectively.

After discussing the titles that indicates operating instructions, it is worth analysing the sentences used to convey such instructions. Thus, the following table will give a clear image about sentence types used in operating instructions.

	Sentence type	frequency	Number of sentences
1	Imperative	6	46
	Declarative	37	
	Conditional	3	
2	Imperative	1	69
	Declarative	68	
	Conditional	0	
3	Imperative	1	15
	Declarative	13	
	Conditional	1	
4	Imperative	31	149
	Declarative	104	
	Conditional	14	
5	Imperative	28	53
	Declarative	25	
	Conditional	0	
6	Imperative	19	21
	Declarative	1	
	Conditional	1	
Total of each type	Imperative	86	353
	Declarative	248	
	conditional	19	

Table 35. Sentence types of operating instructions

The above table (35) shows the types of sentences used to convey the operating instructions. They are extracted from six manuals, as the other manuals do not involve operating instructions. As indicated in the table, 353 sentences are constructed using three different types: imperative, declarative and conditional. The most frequent type is declarative sentences. This implies that the instructions are conveyed indirectly to the technician. That is, instead of giving him direct instructions through the imperative, declarative sentences are used to describe the actions to be performed and to provide additional information as why he has to perform the task at hand. In other words, the operating instructions analysed through the six service manuals are purely descriptive. In terms of frequency, out of 353 sentences that convey operating instructions 282 sentences are declarative. Although the declarative sentences are the prominent type, imperatives are still present in the operating instructions as they represent 86 sentences. Such sentences are used to make the information precise and concise. In addition, using the imperative to express such information is also intended to show its importance to the reader/technician. Thus, tasks and actions conveyed through the imperative leave no choice to the technician but to perform them accordingly. conditional sentences tend to be less frequent; their use in the operating instructions is marked with only 19 sentences to warn the technician of potential risks or express tasks that need to be performed in certain circumstances.

Knowing that there is a use of different types of sentences in operating instructions, it is worth considering the diversity of words used to build such sentences. In order to do so, the latter is submitted to vocabulary profiler and presented in the following table.

	<u>Families</u>	<u>Types</u>	<u>Tokens</u>	<u>Percent</u>
K1 Words (1-1000):	347	511	4258	63.21%
Function:	(2552)	(37.89%)
Content:	(1706)	(25.33%)
> Anglo-Sax =Not Greco-Lat/Fr Cog:	(625)	(9.28%)
K2 Words (1001-2000):	121	167	728	10.81%
> Anglo-Sax:	(382)	(5.67%)
1k+2k		(74.02%)
AWL Words (academic):	111	171	665	9.87%
> Anglo-Sax:	(58)	(0.86%)
Off-List Words:	<u>?</u>	<u>446</u>	<u>1085</u>	<u>16.11%</u>
	579+?	1291	6736	100%

Table 36. Vocabulary profiler of operating instructions

The table shows the different categories of words used in the operating instructions of the analysed service manuals. These categories include English common words, academic words and technical words. The words used from the first category represent 74.02% of the operating instructions' vocabulary. More particularly, such category involves two ranges indicated as K1 and K2. Their presence in the operating instructions' vocabulary is marked with 63.21% and 10.81% respectively. In addition, the first range in the common words tend to be based on two sub-categories including function and content words. Therefore, 63.21% of K1, which appears in operating instructions vocabulary, consist in fact of 37.89% of function words and 25.33% of content ones. Academic words represent 9.87% of the words that appears in the vocabulary. Following the table, there is another category marked as Off-list words. In fact, this category includes technical words that represent 16.11% of the words used in the operating instructions.

5.2.8. Disassembly instructions

1. HOW TO DISASSEMBLE
2. DISASSEMBLY INSTRUCTIONS
3. Disassembly and Reassembly
4. Mechanical Disassembly
5. DISASSEMBLY AND FUSE REPLACEMENT
6. Instrument disassembly
7. DIASSEMBLY INSTRUCTIONS
8. Disassembly
9. DISASSEMBLY ADVICE STAND
10. Disassembly and Assembly Instructions
11. DISASSEMBLY
12. DISASSEMBLY

The above list represents the titles used to indicate disassembly instructions in service manuals. Not all of the analysed manuals show the use of such instructions hence there are only twelve manuals, out of fifteen, that involve disassembly instructions. The titles consist of one to four words. Although the word ‘disassembly’ appears in all the presented titles, it co-occurs with other different words. First, the word ‘disassembly’ is used alone as a title as in the case of (8), (11) and (12). Unlike these instances, some of the titles add other words to specify what kind of disassembly such as the case of (4) and (6) where there is the use of ‘mechanical disassembly’ and ‘instrument disassembly’ respectively. Second, the word ‘disassembly’ appears as the first word in some of the titles including (2), (3), (5), (7), (9) and (10). It tends to be used in two patterns; one of them is to use it with another noun as in the case of (2), (7) and (9), namely ‘disassembly instructions’ and ‘disassembly advice stand’. The other pattern uses it with conjunction ‘and’ as in (3), (5) and (10), namely ‘disassembly and assembly’, ‘disassembly and fuse replacement’, and ‘disassembly and assembly instructions’ respectively. In fact, the titles that use ‘and’ include more than just

disassembly information. Thus, some of them involve disassembly and assembly information together while others involve other information as ‘fuse replacement’ for instance.

The intended meaning conveyed through the titles depends to some extent on the number of words used in their constructions. That is, the more words used in titles, the more information is conveyed to the reader/technician. In addition, titles using more than one word tend to be more precise than the others. For instance, consider the case of (4) and (8). In case of (4), there is the use of two words ‘mechanical disassembly’ whereas in (8) it consists of only one word. Therefore, in terms of precision, (4) tends to be more precise as it specifies that the disassembly information being presented is a mechanical one. However, instance (8) does not provide such precision; it rather refers to all the disassembly information needed, be it mechanical or not. Thus, the reader/technician is more likely to go through the instructions to find the intended information. Third, it is possible to use adverbs to indicate the type of information that is presented by the title as in the case of (1). That is, using the adverb ‘how’ is to specify the appropriate way of disassembling the product. Such title implies that there are a series of steps to be followed in order to perform such task. In other words, considering the two words that appear in the title, that is, ‘how to’, they are generally understood as set of instructions. Therefore, the title is referring to disassembly instructions using different words.

Although the titles discussed above, use different structure and different words, they have a common task that is to indicate the type and the place of the information being presented within the manual to help the reader/technician find them easily. However, the way information is presented to the reader/technician differs from one manual to another depending on its style and structure. So, the instructions intended for

disassembly are analysed in terms of sentences types. Thus, depending on the type of sentences used in the disassembly instructions, information can be conveyed either directly or indirectly. For this purpose we will consider the following table that provides the different sentence types along with their frequency of use.

Sentence type		Frequency	Number of sentences
1	Imperative	13	15
	Declarative	2	
	Conditional	0	
2	Imperative	49	50
	Declarative	0	
	Conditional	1	
3	Imperative	38	42
	Declarative	4	
	Conditional	0	
4	Imperative	17	17
	Declarative	0	
	Conditional	0	
5	Imperative	2	3
	Declarative	1	
	Conditional	0	
6	Imperative	88	131
	Declarative	43	
	Conditional	0	
7	Imperative	47	52
	Declarative	5	
	Conditional	0	
8	Imperative	21	29
	Declarative	8	
	Conditional	0	
9	Imperative	53	57
	Declarative	3	
	Conditional	1	
10	Imperative	83	87
	Declarative	3	
	Conditional	1	
11	Imperative	127	131
	Declarative	4	
	Conditional	0	
12	Imperative	102	104
	Declarative	2	
	Conditional	0	

Total of each type	Imperative	640	718
	Declarative	75	
	Conditional	3	

Table 37. Sentence types of disassembly instructions

As shown in the table (37), there are three different sentence types used to convey the disassembly information to the technician. These are imperative, declarative and conditional. In addition to their frequency, the table provides the number of sentences used to convey such information in each manual as well. Thus, while some manuals use only 3 sentences, others use 131 sentences to express disassembly instructions. Although these instructions are based on three types of sentences, there is a frequent use of one type over the others. Thus, taking into consideration 718 sentences used to represent the disassembly instructions, the imperative sentences are used overwhelmingly to convey such instructions. In fact, 640 sentences in the disassembly instructions are conveyed through the imperative; using the imperative implies that, the information is directly conveyed to the reader/technician. Although there is the use of other types as declaratives and conditionals, they are not used as frequently as the imperatives. In terms of frequency declarative sentences represent only 75 of sentences. Since they generally convey additional information, they tend to be used only when necessary as for instance to explain why the technician has to perform a given action. The same thing can be said about the conditionals except that they are rarely used depending of the nature of the information being presented. In this case, the use of conditional is limited to 3 sentences that make them less significant in disassembly instructions.

The disassembly instructions are not only conveyed through different sentence types, but the words used in their constructions are more likely to be varied as well. In order to know the nature of the vocabulary used in the disassembly instructions, it is

submitted to the vocabulary profiler, which can identify different categories of words that are presented in the table below.

	<u>Families</u>	<u>Types</u>	<u>Tokens</u>	<u>Percent</u>
K1 Words (1-1000):	262	327	3227	57.18%
Function:	(1954)	(34.62%)
Content:	(1273)	(22.55%)
> Anglo-Sax	(577)	(10.22%)
=Not Greco-Lat/Fr Cog:		
K2 Words (1001-2000):	102	140	743	13.16%
> Anglo-Sax:	(326)	(5.78%)
1k+2k		(70.34%)
AWL Words (academic):	53	65	440	7.80%
> Anglo-Sax:	(132)	(2.34%)
Off-List Words:	<u>?</u>	<u>311</u>	<u>1234</u>	<u>21.86%</u>
	417+?	840	5644	100%

Table 38. Vocabulary profiler of disassembly instructions

It seems that the words used in the vocabulary of disassembly instructions involve different categories. Thus, following the table the identified categories include English common words, academic words and technical words referred to as Off-list words. As shown in the table, the presence of each category in the vocabulary is clearly marked with a percentage. The English common words represent 70.34% of the ‘disassembly instructions’ words and include the combination of K1 and K2: 57.18% of the words belong to K1 and 13.16% to K2. However, the vocabulary of disassembly instructions includes 7.80% of academic words and 21.86% of technical words.

5.2.9. Troubleshooting

1. TROUBLE SHOOTING GUIDE
2. Troubleshooting
3. TROUBLESHOOTING
4. Troubleshooting
5. Diagnostics
6. Troubleshooting Chart
7. TROUBLE SHOOTING METHODS ACCORDING TO DISPLAYED ERROR MODE
8. TEST AND CHECKOUT PROCEDURES, AND TROUBLE SHOOTING
9. TROUBLE SHOOTING METHODS
10. Troubleshooting
11. Flow Chart of Troubleshooting

The titles presented above are to indicate troubleshooting in service manuals. They are of different structure and length. As not all of the fifteen analysed manuals show the use of such information, the titles represent only twelve manuals where some titles are constructed using one word while others use ten words. Although the word ‘troubleshooting’ appears in most of the identified titles, they may use different words to indicate troubleshooting such as ‘diagnostics’, which is the case for (5). In addition, the words ‘troubleshooting’ co-occur with different words such as ‘guide’, ‘method’ and ‘chart’. Despite the use of such words, troubleshooting is more likely to be presented in the same way. That is, in service manuals, troubleshooting information is presented to the technician in a chart or diagram that explains how to identify the problem within the product. Thus, regardless of the words used with ‘troubleshooting’, such as ‘guide’ or ‘method’, they generally refer to trouble shooting chart. Moreover, the length of the title is to show how much information the title provides to the reader/technician. The titles that have many words are more likely to give more clues about the nature of information being presented. However, short titles are more likely to provide information implicitly; using few words in the titles does not always mean there is less information being presented. Considering the types of the words used to create the presented titles, it seems that most of the words involved are nouns with exception

for the long titles that involve other types of words as conjunctions such as the case of (8).

Although the titles are indispensable to the reader/technician to spot information within the service manuals, they do not provide troubleshooting information themselves, but they make him access them easily. Therefore, the main concern of the technician is the necessary information that guides him to troubleshoot the product. Knowing that, it is more convenient to know how troubleshooting instructions are conveyed to the technician. Thus, in order to have a clear image about such instructions, they are analysed in terms of sentence types. In fact, the analysis helps to reveal whether they are conveyed directly or indirectly depending on the sentence type they use. To give it a substance, we consider the following table, which provides the main sentence types used in the troubleshooting instructions. In addition, it includes the frequency and the number of sentences used in each service manual.

	Sentence types	Frequency	Number of sentences
1	Imperative	26	52
	Declarative	26	
	Conditional	0	
	Interrogative	0	
2	Imperative	52	141
	Declarative	50	
	Conditional	24	
	Interrogative	15	
3	Imperative	68	139
	Declarative	50	
	Conditional	1	
	Interrogative	20	
4	Imperative	51	92
	Declarative	36	
	Conditional	0	
	Interrogative	5	
5	Imperative	49	111
	Declarative	5	
	Conditional	0	

	Interrogative	57	
6	Imperative	122	258
	Declarative	41	
	Conditional	5	
	Interrogative	90	
7	Imperative	44	96
	Declarative	44	
	Conditional	0	
	Interrogative	8	
8	Imperative	35	81
	Declarative	44	
	Conditional	1	
	Interrogative	1	
9	Imperative	59	99
	Declarative	28	
	Conditional	0	
	Interrogative	22	
10	Imperative	144	186
	Declarative	72	
	Conditional	0	
	Interrogative	0	
11	Imperative	4	7
	Declarative	3	
	Conditional	0	
	Interrogative	0	
Total of each type	Imperative	623	1262
	Declarative	400	
	Conditional	31	
	Interrogative	208	

Table 39. Frequency of sentence types in troubleshooting instructions

As shown in the table (39), different sentence types are identified within troubleshooting instructions; they involve imperative, declarative, conditional and interrogative types. Thus, unlike other instructions troubleshooting makes use of interrogatives. In fact, troubleshooting instructions are conveyed through 1262 sentences identified in the analysed service manuals. The most prominent type of sentences is the imperative, which represent 623 sentences of the total number of sentences used to express troubleshooting instructions. As a result, troubleshooting instructions are expressed directly to the technician through imperatives. In addition,

declarative sentences show significant presence in the troubleshooting instructions hence they represent 400 of the sentences. Although conditional sentences do appear in such instructions, they are not as frequent as imperatives or declaratives. Thus, in such instructions, their use is limited to 31 sentences. On the other hand, 208 interrogatives are remarkably used to convey troubleshooting instructions.

The use of different sentence types to express the troubleshooting instructions is due the fact that they include different pieces of information that help the technician to service the product. Thus, regardless of the way such information is presented to the technician, it entails information as ‘the problem’, ‘cause of the problem’ and ‘solution for the problem’. Each of which is conveyed through a different sentence type most suitable for the nature of the information. More particularly, ‘the problem’ is presented using declarative sentences; however, in some service manuals they use interrogative sentences instead. ‘The cause of the problem’ is also conveyed through declaratives. How to fix the problem is mostly expressed through the use of imperatives. In addition, interrogatives and imperatives may also be used to present troubleshooting information but a chart instead of a table represents them, which is the case for user manuals. The chart uses a method of elimination in order to make the technician identify the source or cause of the problem. Thus, interrogatives refer to questions in the chart that the technician has to answer using either yes or no. If the answer is yes then the problem is more likely to be identified but if the answer is no he has to follow the chart again which leads him to other possible problems until he finds the problem in question.

After dealing with sentence types in troubleshooting instructions, it is worth considering the vocabulary used to produce such sentences. Therefore, the vocabulary representing troubleshooting instructions is analysed using vocabulary profiler as shown in the table (44)

	<u>Families</u>	<u>Types</u>	<u>Tokens</u>	<u>Percent</u>
K1 Words (1-1000):	365	519	6709	59.47%
Function:	(3879)	(34.39%)
Content:	(2830)	(25.09%)
> Anglo-Sax	(1297)	(11.50%)
=Not Greco-Lat/Fr Cog:		
K2 Words (1001-2000):	139	200	1371	12.15%
> Anglo-Sax:	(704)	(6.24%)
1k+2k		(71.62%)
AWL Words (academic):	107	161	848	7.52%
> Anglo-Sax:	(94)	(0.83%)
Off-List Words:	<u>?</u>	<u>531</u>	<u>2353</u>	<u>20.86%</u>
	611+?	1407	11281	100%

Table 40. Vocabulary profiler of troubleshooting instructions

As they appear in the table (40), the different categories of words identified in the troubleshooting instructions, using the profiler, are English common words, academic words, and Off-list referring to technical words. Common words are represented by two sub-categories indicated as K1 and K2. They represent 59.47% and 12.15% respectively. In sum, they represent 71.62% of the vocabulary being analysed. In addition, the profiler shows that 7.52% of the words, used to build the vocabulary, belong to the academic words. Moreover, the vocabulary of troubleshooting shows a significant use of technical words with 20.86% of the words used in the vocabulary.

Conclusion

The linguistic realisation of the identified moves revealed that lexical sets and sentence types differ moving from one move to another within the same type of the manual. Such variation is clearly noticeable considering the type of the manual as in the case of service manuals. Each move is identified with linguistic features that reflect clearly its nature and purpose. Thus, the prominence of use, in terms of lexical sets and sentence types, depends on the move itself as well as the type of the manuals at hand. A comparison is provided in the next chapter.

Chapter six: Comparison of moves and summary of results

Introduction

This chapter aims to compare the identified moves in both types of user and service manuals. It shows and determines the differences and similarities in the move structure used in the manuals. First, it describes the common moves that they share. Second, it shows the unique moves that each type of manual has as its distinctive feature. Finally, a summary of results and findings is provided.

6.1.Shared moves

6.1.1. Read the manual

The first move to be identified in both types of manuals is to ask the user to “read the manual”. Although both types of manuals seem to use the same move, they do not share the same purpose. That is, they differ in why they ask the user to read the manual. To make it clear, we consider the following examples:

- a) Please read this manual carefully before operating your set and retain it for future reference.
- b) Before servicing the unit, please read this manual carefully for safety and correct services.

These two examples, namely (a) and (b), represent the first move in user and service manuals respectively. In both examples, there is a request to read the manual. But, what makes them different is the purpose. While in user manuals the user is asked to read the manual to be able to operate correctly the product at hand, in service manuals the user, who is the technician, is supposed to read the manual so that he can correctly and safely repair the product. However, the types of manuals share some features in the way they address the user/reader. That is, they express the request of

reading the manual through the use of the imperative. Knowing that being very direct in requesting is less polite, they make use of the word ‘please’ to achieve politeness.

In addition, the vocabulary used to convey such request and hence to realise the move that characterises both manuals show to some extent that they use the same type of vocabulary. To give it substance, consider the following table that represent the results of submitting the vocabulary of such move to vocabulary profiler.

Types of words	User manuals	Service manuals
Common words	81.86%	81.82%
Academic words	11.40%	10.39%
Technical words	6.74%	7.79%

Table 41. Vocabulary profiler of user and service manuals

The table is to compare the vocabulary used in each type of manuals in terms of the first move. The comparison is based mainly on three categories of words, namely English common words, academic words and technical words. Thus, following the table common words are present in both manuals to express, approximately, 81% of the words used in the vocabulary of the first move. However, considering academic words, the two types of manuals show a slightly difference in the use of such words. More particularly, 11% of the words in first move are academic while in service manual they appear as 10%. In like manners, technical words differ in their frequency of use in both manuals. While 6% of technical words are used in user manuals, there is a use of 7% of such words in service manuals.

6.1.2. Safety instructions

Safety instructions, as an important piece of information, are used in both types of manuals. However, this kind of information is expressed differently in both manuals since they address different types of audience namely public and professional. The difference in both manuals refers to the nature of the information presented to the user.

In other words, safety instructions in user manuals are presented differently because they include other pieces of information as ‘safety information’. Such information is to provide the user/reader, in this case it is the layman, with the symbols and signs used in the manual to indicate warnings or potential danger. As far as safety is concerned, safety information is provided before safety instructions because without which the user/reader is unlikely to understand fully the instructions involving these signs and symbols. However, it is not the case for service manuals in which the instructions about safety is directly presented to the technician. The reason behind this lies in the fact that the technician is a trained and qualified person who knows the necessary precautions and safety measures that are to be taken before servicing the product; they are part of his training and knowledge that make him identify such signs and symbols even if they are not explained. In addition, these symbols and signs are written using conventions in order to be identified by technicians who share such conventions.

In spite of such differences, the user manual or service manual share the same purpose behind offering such information to the users. Therefore, they both seek the safety of the user and the product at hand. They use warnings and cautions to make the user aware of the risks and danger that may cause injuries and even death. On the other hand, they warn him about actions that may damage the product so as to avoid them while in operation. In order to understand how such move is realised in both manuals the following table presents the analysis of instructions in terms of sentence types.

Sentence types	User manuals	Service manuals
Imperative	167	213
Declarative	67	117
Conditional	13	28

Table 42. Sentence types of safety instructions in user and service manuals

Since the analysed sentences may differ in their number in the two types of manuals, the prominent sentences types in each type of manuals is considered as a basis of comparison. Following this assumption, the prominent type in both manuals tends to be the imperative one. In addition, the declarative sentences are used differently in the sense that user manuals include less declaratives than imperatives while in service manuals they are used as equally important as imperatives. To put it differently, user manuals show overwhelming use of imperatives while service manuals show significant use of both imperatives and declaratives to express safety instructions.

6.1.3. Installation instructions

Installation instructions are used to ensure the correct installation of the product. Depending on the nature of the product, such instructions may not be used in some manuals. However, not following the instructions may lead to bad consequences because if the product is not installed appropriately it affects its performance as it may cause a serious damage to the product. Due to the importance of these instructions, they appear in both types of manuals, namely user and service manuals. Thus, regardless of the user, whether laymen or professional, the information provided to him is to ensure good performance of the product through appropriate installation. It seems that both types of manuals have a common purpose that is appropriate installation and hence good performance. Although they share such general purpose of installation, they differ in the primary purpose for which these set instructions are used in both manuals. While such instructions are to explain the appropriate installation of the product, in service manuals they have other purpose of use. In fact, the technician responsible for repairing the product must also know the appropriate installation of the product. Hence inappropriate installation can affect the performance of the product; it is a part of his job to check such problems.

Thus, in some cases the poor performance of the product is only a matter of installation. To put differently, in addition to ensuring good installation, the purpose of using installation instructions within service manuals is to help the technician to fix the problems of inappropriate installations.

In addition to the difference in the purposes behind the use of these instructions, the sentences used to convey such information are considered to reveal other possible differences between the two types. The following table provides the main sentence types used in each type of manuals to convey these instructions.

Sentence types	User manuals	Service manuals
Imperative	87	83
Declarative	34	69
Conditional	11	11

Table 43. Sentence types of installation instructions in user and service manuals

The table shows clearly that three types of sentences are identified in both types of manuals. Although they use the three types, namely imperative, declarative and conditional to convey the instructions, they differ in their distribution and prominence in each type of manuals. The prominent sentence type in each type of manuals seems to be the imperative sentence. Equally significant to imperative is the declarative sentence. Conditional are less frequent in both types of manuals. Although declarative sentences are considered significant, their use in both manuals is quite different in the sense that declaratives are used more in service manuals than in the user ones. This assumption is based on the difference between the two sentence types, namely imperatives and declaratives in each manual. That is the gap between the imperative and declarative in user manuals is bigger than that of service manuals. Hence, we can say that the service manuals are to express their instructions

using both imperatives and declaratives while instructions in user manuals are conveyed mainly through the imperative.

6.1.4. Operating instructions

As their name indicates, operating instructions enables the user to operate or use the product within the purpose for which it is designed. In fact, operating instructions are meant to be the core or heart of the manuals. They instruct the user about the product at hand by providing different steps needed for correct use. But, why do they include different steps? Because operating the product is not done in one step rather it is a whole process that needs different actions on the part of the user. This consideration is shown clearly in the titles of such instructions through the use of gerund ‘operating’, which indicates that there is a process to be considered.

Although operating instructions are present in both types of manuals, they differ in their intended purpose. On the one hand, the user manuals provide such instructions to seek correct use of the product by the user. On the other hand, operating instructions are needed in the repairing process because the technician is more likely to power on the product to perform a series of tests that help to identify the source of the problem. Thus, the technician must know how to operate the product in order to fix it. In addition, he may encounter different types of models of the same product; regardless of his experience he may face some difficulties in operation if he is not aware of the operating instructions.

Since operating instructions are used to accomplish different purposes in user and service manuals, it is worth considering the sentences used to convey such

instructions. The following table gives a clear image about the sentence types used to express operating instructions in both types of manuals.

Sentence types	User manuals	Service manuals
Imperative	175	86
Declarative	154	248
Conditional	39	19

Table 44. Sentence types of operating instructions in user and service manuals

Operating instructions tend to be expressed through three different sentence types including imperative, declarative and conditional. Although both types of manuals show the use of such sentence types to convey operating instructions, they differ in their frequency and significance in each type of manuals. The most prominent sentence type in user manuals is the imperative. Declarative sentences seem to be used remarkably to convey such instructions. In user manuals, there is a little difference in frequency between the imperatives and the declaratives. In addition, conditional sentences show some increase in frequency in operating instructions. In service manuals, on the other hand, imperative sentences are less frequent in operating instructions. As a result, declarative sentences are to be the most prominent type. Conditional sentences show only few occurrences in such instructions. Here, we can notice that declarative sentences are more used in operating instructions than other types of instructions; hence they are used as significant as imperatives in user manuals and overwhelm the imperatives in service manuals.

6.1.5. Troubleshooting

In user manuals, troubleshooting are meant to help the user to fix minor problems that he may face while operating the product. Such problems are usually due to misuse or lack of appropriate installation because the user ignored or

misunderstood given instructions. The user can notice these problems in the performance of the product and identify their source relying on the error messages that appear in the product. In fact, error messages are of great help to the user because they give a clear idea about the nature of the problem. However, the errors are expressed through coded messages that make the user refer to the troubleshooting instructions that explain clearly such messages. In addition to error messages, troubleshooting gives the possible causes of some of the problems that may not appear in the error messages. Generally, such information is presented in three pieces that involve mainly 'the problem', 'the possible' causes and 'suggested solutions'. As mentioned earlier, troubleshooting in user manuals is to fix minor problems that prevent the product from giving a good performance. However, in case of serious problems, the user cannot rely on the instructions provided in troubleshooting because the problem may be due to a defect in some parts of the product that need to be replaced. In this case, the product has to be serviced by qualified person to make the necessary repairs. Unlike user manuals, in service manuals troubleshooting gives appropriate instructions to repair the product in question. So, this kind of instructions is only found in service manuals that are devoted to the technicians. Since their aim is to identify the source of the problem and give necessary repairs, the information provided by troubleshooting instructions differs from that of user manuals. Thus, instead of giving suggested problems and solutions, which is the case in user manuals, they are presented in a chart that is based on an elimination process. That is, the technician has to go through the chart in order to identify the problem. Such method is based on 'no' 'yes' questions. If the answer is 'yes', he has to follow the instructions provided afterwards, which means

that the problem is identified. However, if the answer is ‘no’, he has to move to another step until the problem is identified.

We can notice, here, that there is a difference in troubleshooting instructions in both types of manuals. Accordingly, troubleshooting serve different purposes depending on the manuals. Hence they differ in purposes and structure, the sentences used to convey such instructions are discussed so that to have better understanding of such differences. The following table provided the identified sentence types in troubleshooting instructions in both types of manuals.

Sentence types	User manuals	Service manuals
Imperative	303	623
Declarative	334	400
Conditional	28	31
Interrogative	22	208

Table 45. Sentence types of troubleshooting in user and service manuals

Troubleshooting instructions, as shown in the table, are expressed through a variety of sentence types that include imperatives, declaratives, conditionals and interrogatives. The first three sentence types are usually identified in most of the analysed instructions. However, it is not the case for interrogatives because they do not appear in all kinds of instructions. Thus, unlike other types of instructions, troubleshooting involves the use of questions, which are represented usually with interrogatives. Although interrogatives are used in both types of manuals, they differ in the way they are presented in the manuals. As mentioned earlier, troubleshooting in user manuals are conveyed through three pieces of information, which are usually organised in a table. Such questions, or interrogatives, are used to express ‘the suggested problems’ in the table of troubleshooting. In fact, service manuals use interrogatives to identify the source of the problem by answering the questions with ‘yes’ or ‘no’. In spite of that, the interrogatives are less used in troubleshooting for

user manuals because most of the sentences are conveyed through declaratives, which appear as the most prominent sentence type. In user manuals, imperatives mark their presence with a significant frequency that is close to that of declaratives. Although conditionals used to be the less frequent sentence types in most of the instructions, they show considerable presence in troubleshooting. Their role is to signal that the requested actions are to be performed under a given conditions, as they may be used to express other options to perform the same actions.

In service manuals, such sentence types seem to be used differently to convey the instructions of troubleshooting. Thus, in addition to the difference in the purpose they serve, user and service manuals differ also in the way they convey instructions of troubleshooting. As opposed to user manuals, the most prominent sentence type in service manuals is the imperative. Declarative sentences still show a powerful presence in such instructions hence they support the imperatives with the necessary explanations. Another noteworthy occurrence is that of interrogatives. Such frequency is to be expected hence they are indispensable to guide the technician in finding the source of the problem. Conditionals being less used in comparison to other sentence types but they are effective to warn the technician about the necessary conditions under which he has to perform the intended actions.

6.1.6. Product features

Contrary to other instructions, which are mostly conveyed through sentences, product features are expressed using different rhetorical function namely that of verbal-visual. While verbal refers to text used for description or explanation, visuals represents illustrations, drawings, graphs and so on. Although they can serve different purposes, in product features, generally, their main function is to show the product shape and design to the user. In fact, the information provided by visuals, namely drawings in product

features, is of great value because they make the user familiar with his product. Thus, their role is to introduce the product to the user by giving him the names of different parts and their functions. Such features help the user to get started with the product and also make him know how to assemble the accessories when needed.

The product features are used in user and service manuals to accomplish different purposes and help achieving the general objective of user and service manuals that is ‘operating’ and ‘servicing’ the product respectively. As a result, product features in service manuals are to make the technician aware of the different features included in the product, particularly when it is a new product with different design and parts from those he used to repair. However, apart from differences in purposes, they are presented using the same rhetorical function, namely verbal-visual relationships, as it is the case in the following figures.

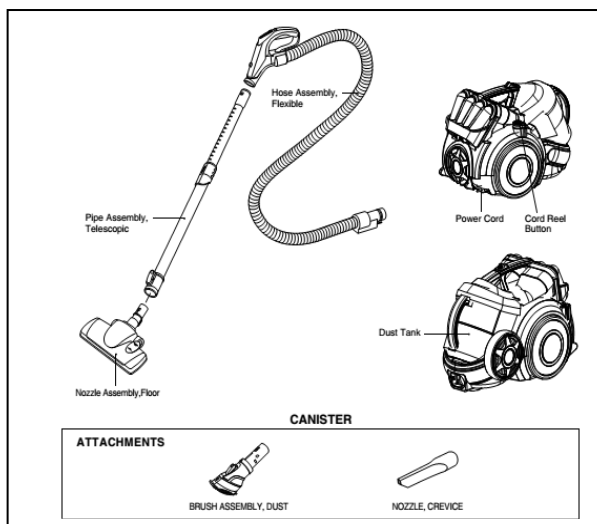

Figure 24. Product features in user manuals

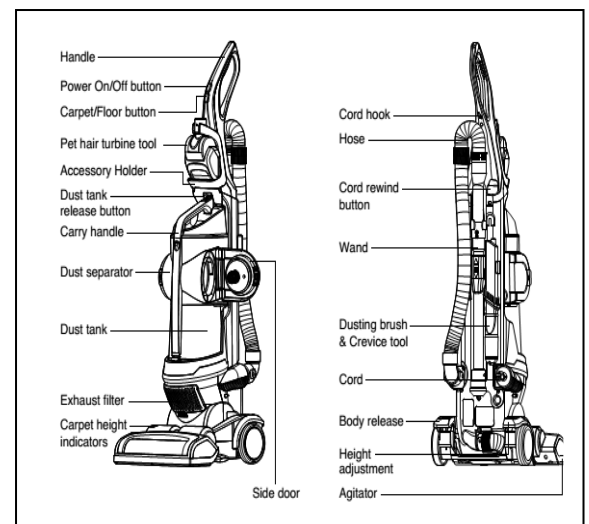

Figure 25. Product features in service manuals

The figures (24) and (25) represent an instance of ‘product features’ in user and service manuals respectively. Clearly, the figures reveals that visuals used to convey product features in both types of manuals are drawings that show the shape and design

of the product. In addition, they give names of different parts of the product along with accessories, which is the case in user manual figure (24). The verbal indicates the names of the parts through the use of arrows that point to the specified part. In this case, the verbal is included in the drawings themselves and not separate from them. The following figures illustrate the point.

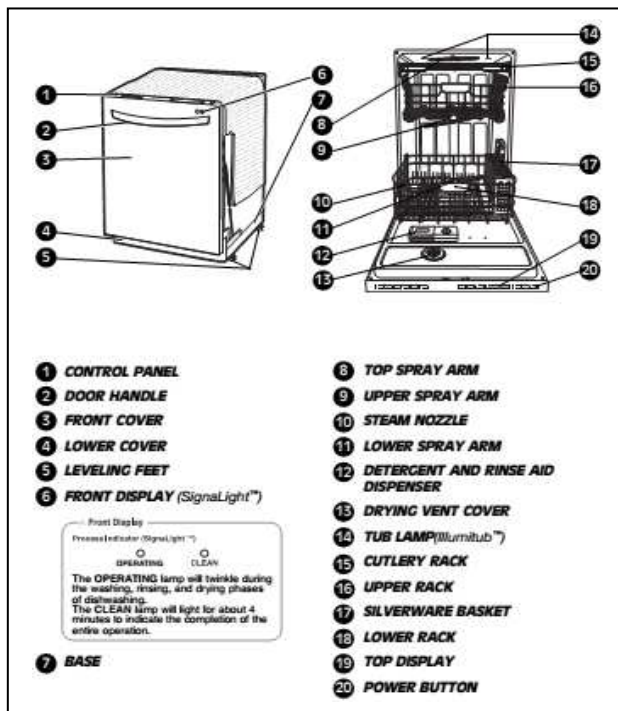

Figure 26. Product features in user manuals

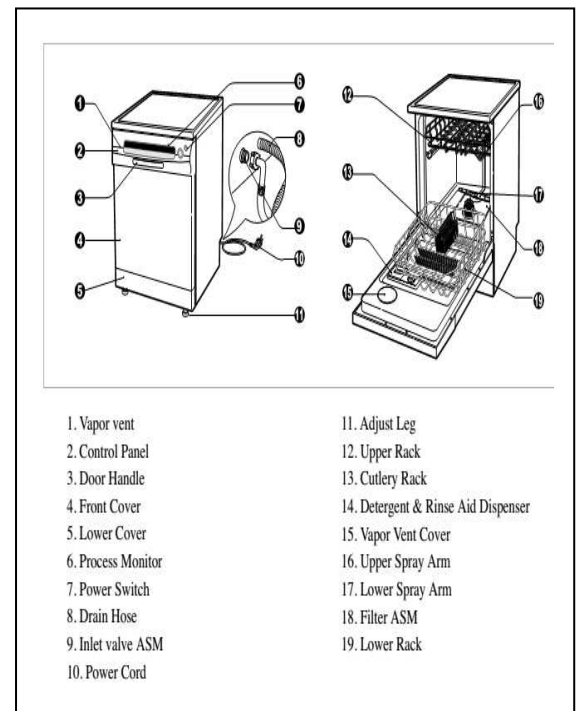

Figure 27. Product features in service manuals

The figures (26) and (27), which are extracted from user and service manuals respectively, are just another instance of product features conveyed by the use of verbal-visual rhetorical function. However, these instances differ from the previous ones in that the verbal is separate from the visual in the sense that numbers linked with arrows are used to indicate the names of the parts. Each part is represented by a number, which appears in a list, and includes all the parts, below the drawings of the product.

6.1.7. Specifications

Similar to product features, specifications are very likely to familiarise the user with the product at hand. However, it is not about features but rather about technical information of the product. Such information is very important hence it gives a clear image about the product capacity, dimensions, voltage supply and so on. For instance, dimensions help to choose the appropriate place where to install the product; on the other hand, voltage supply makes the user to select the correct voltage supply to power it. In addition, specifications ensure that the user does not abuse the product. That is, using it for different tasks without considering the specifications under which it is designed. Furthermore, specifications are critical to know whether the product meets the designed specifications or not. In other words, the performance of the product must be just as mentioned in the specifications otherwise it would be ‘out of spec’. In this case, the user/customer can claim for repair or replacement of the product. Therefore, specifications are very helpful to save the user/customer rights.

Furthermore, specifications can serve different purposes depending on the type of the manual. Thus, in service manuals the technical information that is provided through specifications is to help the technician in the repairing process. If the defect of the product is due to being ‘out of spec’, the technician can find out immediately by checking its specifications. Another worthy point is that specifications in service manuals are more detailed than those in user manuals. For example, we consider the following figures.

Height (adjustable)	85.0 cm
Width	59.5 cm
Depth	54 cm
Capacity (max.)	7 kg
Weight (net)	31 kg
Voltage	See type label
Rated power input	
Model code	

Figure 28. Specifications in user manuals of tumble dryer

ITEMS	TD-C70040E	REMARK
MATERIAL & FINISHES		
DRYING TYPE	Condensation	
WEIGHT	40 kg (Gross : 46 kg)	
DIMENSION	595(W) x 850(H) x 600(D)	
STANDARD DRYING CAPACITY	7.0 kg	
CONTROL TYPE	Electronic Control	
POWER SUPPLY	AC 220~230V, 50Hz (16A)	LGEUK:13A, LGEAP:10A
MOTOR	250W	
HEATER	2500W(22.5)	LGEUK:2350W, LGEAP:1900W
LAMP	15W(125mA)	
DOOR SWITCH	250V(10A)	
THERMOSTAT	240V(25A)	
CONTROL TYPE	Electronic	
DRUM CAPACITY	116 Liter	
SAFETY DEVICES	Thermal Fuse (Motor) Over current protect (Motor) Thermostat	
SENSING TYPE	Micom electronic Control 1. Temperature : 2 thermistors 2. Humidity : Electrode Sensor	
FILTER	Removable (Double screen)	
DRUM SPEED	56~57 rpm	
REVERSIBLE DOOR	Available	
DRUM	Stainless steel	
DRYER RACK	Available	
CHILD LOCK	Available	
TEMPERATURE CONTROL	Available (High/Low temp buttons)	Default : ON
BUZZER	Available	Default : OFF
ANTI-CREASE COURSE	Available	
FAVOURITE COURSE	Available	3~19 hours
TIME DELAY	Available	
DRUM INTERIOR LIGHT	Available	
LED DISPLAY	TIME DISPLAY RUNNING STATUS INDICATOR EMPTY WATER CLEAN FILTER CHILD LOCK	

Figure 29. Specifications in service manual of tumble dryer

The figures (28 and 29) show the difference in the information provided in each type of manuals. Thus, the specifications in user manuals tend to give general information about the product, as shown in figure (28), including width, depth, capacity and so on. However, service manuals give more technical information hence they are used to support the technician. So, the specifications, as in figure (29), offer more than dimensions and voltage supply; they also include information about, motor, speed, thermostat, door switch and so on. Although such information is of great importance to the technician, it is of no use to the lay-user. Therefore, determining the nature of information to be presented depends mainly on the needs of the end-user whether it is a laymen or a professional.

6.2.Moves unique to user manuals

6.2.1. Thanking the customer

One of the communicative purposes of user manuals is selling which is expressed implicitly through the use of such move of ‘thanking the customer’. Since companies generally want to attract more customers to their brand, in user manuals they thank the customer right at the beginning of the manual to show their gratitude and appreciation. In addition, they seek to leave a positive lasting impression about their products; thanking the customer is one of the marketing strategies to win his satisfaction in the first purchase. Moreover, as the customer may not be sure about the correctness of his purchase decision, thanking him is used to get rid of such worries and dissonance and tell him that he made the right choice. For example, we consider the following.

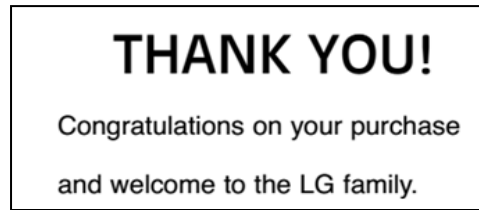

Figure 30. Thanking the customer in user manuals

With reference to figure (30), congratulation and welcome are used in addition to ‘thank you’ to build a solid relationship between the company and the customer. Thus, ‘congratulations’ is to show that he made the right decision that will give him more confidence. ‘Welcome’, on the other hand, is to tell him that he is now a customer of the company brand, which is LG in this case. Moreover, the word ‘family’ is used along with ‘welcome’ to express that their relationship to the customer is as close as that of family and by welcoming him is to show his importance to the family. We can notice that the relevant choice of words determines the importance of thanking the customer. On the other hand, service manuals do not show such move that express selling; they rather involve only those that support the technician to effectively repair the product, which will result in the customer satisfaction and saving the company reputation as well.

6.2.2. Warranty

To some extent, warranty is similar to ‘thanking the customer’ in the sense that it brings him confidence. However, it is an act of proving the accuracy and quality of the product. In case of a defect in the product, the company is reliable to such defect according to the terms specified by the warranty at hand. Thus, depending on the type of warranty the company may not be reliable for all the problems found in the product. In addition, warranty terms are only valid during a specified period of time clearly determined by the type of warranty that can be a short or long term one. The terms and period, under which the warranty is effective, are clearly presented to the customer to

make him benefit from any repairs or replacements. By doing so, it saves the customer’s rights; for example consider the following:

LG VACUUM CLEANER WARRANTY

LG Electronics Inc. will repair or replace your product, at LG’s option, if it proves to be defective in material or workmanship under Personal household use, during the warranty period set forth below, effective from the date of original consumer purchase of the product. This limited warranty is good only to the original purchaser of the product and effective only when used in U.S.A and Canada.

WARRANTY PERIOD:	HOW SERVICE IS HANDLED:
Five Year From the date of the original purchase	Any part of the vacuum cleaner which fails due to a defect in materials or workmanship. During this full five-year warranty , LG will also provide, free of charge , all labor and shop service to replace the defective part.

THIS WARRANTY IS IN LIEU OF ANY OTHER WARRANTIES, EXPRESS OR IMPLIED, INCLUDING WITHOUT LIMITATION, ANY WARRANTY OF MERCHANTABILITY OR FITNESS FOR A PARTICULAR PURPOSE. TO THE EXTENT ANY IMPLIED WARRANTY IS REQUIRED BY LAW, IT IS LIMITED IN DURATION TO THE EXPRESS WARRANTY PERIOD ABOVE. LG WILL NOT BE LIABLE FOR ANY CONSEQUENTIAL, INDIRECT, OR INCIDENTAL DAMAGES OF ANY KIND, INCLUDING LOST REVENUES OR PROFITS, IN CONNECTION WITH THE PRODUCT. SOME STATES DO NOT ALLOW LIMITATION ON HOW LONG AN IMPLIED WARRANTY LASTS OR THE EXCLUSION OF INCIDENTAL OR CONSEQUENTIAL DAMAGES, SO THE ABOVE LIMITATIONS OR EXCLUSIONS MAY NOT APPLY TO YOU.

*This warranty covers only defects in material and workmanship.
LGE will NOT pay for:*

1. Expendable items that can wear out, including but not limited to filters, belts.
2. A service technician to instruct the user in correct product assembly, operation or maintenance.
3. A service technician to clean or maintain this product.
4. Damage to or failure of this product if it is not assembled, operated or maintained according to all instructions supplied with this product.
5. Damage to or failure of this product resulting from accident, abuse, misuse or use for other than its intended purpose.
6. Damage to or failure of this product caused by the use of detergents, cleaners, chemicals or utensils other than those recommended in all instructions supplied with this product.
7. Damage to or failure of parts or systems resulting from unauthorized modifications made to this product.

This warranty is extended to the original purchaser for products purchased for home use within the USA. In Alaska, the warranty excludes the cost of shipping or service calls to your home. Some states do not allow the exclusion or limitation of incidental or consequential damages, so this exclusion or limitation may not apply to you. This warranty gives you specific legal rights, and you may also have other rights which vary from states to states. To know what your legal rights are, consult your local or state consumer affairs or your state’s Attorney General.

Figure 31. Warranty in user manual of vacuum cleaner

Figure (31) represents a warranty extracted from user manual of vacuum cleaner. The warranty gives different kinds of information to the customer to make him aware of his rights and clarify the company’s reliability towards the product. First, it reminds him about the fact that repair is only performed during warranty period. Second, it gives the exact period of time during which the warranty is valid. It also specifies the type of service to be charged by the company. In this case, it is “free of charge of all labour and service shop to replace the defective part”. Third, it states the terms of warranty in relation to consumer law. That is, it explains the types of warranty, express or limited, and the liability of the company. Fourth, it points out the type of defects to be covered

as material or workmanship. In addition, it determines the type of damages and parts that are not covered; thus, the company will not pay for them.

In some cases, warranty is not used in all manuals because it can be provided separately. In other words, it is not necessary to include it within the manual itself. In many cases warranty comes in a separate leaflet within the same package that includes the manual. Whether printed in the user manual or presented in separate leaflet, the warranty is always provided along the product. Hence, when warranty comes with user manuals, it is unlikely to find one in service manuals. Since the main concern of technician is only to repair the product, he is not obliged to provide or explain warranty terms to the customer.

6.2.3. Clean and maintenance

Maintaining the product is a very important step to keep its good performance and to expand its life cycle. In addition, it saves the owner a lot of money that is usually spent on extensive repairs. User manuals instruct the user about cleaning and maintenance process to ensure good results and preventing him from abusing the product. In many cases, ignoring the cleaning and maintenance lead to serious problems that can damage different parts within the product. Such maintenance procedures are done on regular basis. That is, they may be performed daily, monthly or even yearly depending on the type of the product at hand. Furthermore, the instructions of maintenance are explained through the use of visuals in order to assure that the user performs them exactly as described. Such assumption is best illustrated in the following figure, which represents clean and maintenance of dishwasher.

CARE & CLEANING

For best results, it is important to periodically check and care for the spray arms.

⚠ WARNING To prevent injury during care and maintenance/cleaning, wear gloves and/or protective clothing.

CLEANING METALLIC PARTS

Some exterior and interior parts can be cleaned with a damp cloth or sponge. A cloudy film may form on the surface of the stainless steel tub, especially with hard water.

CLEANING THE LOWER SPRAY ARM

- Make sure that the water jet holes are not blocked by food particles.
- When cleaning is necessary, remove the lower spray arm by pulling up.
- After cleaning the lower spray arm, replace it by pushing down until it clips into place. Be sure the spray arm turns freely.



CLEANING THE UPPER SPRAY ARM



- 1** Pull the upper rack forward. Make sure that the water jet holes are not blocked by food particles.

When cleaning is necessary, remove the upper spray arm by turning the nut on the bottom of the spray arm 1/8 turn counterclockwise and pulling down (see illustrations).



- 2** After cleaning the upper spray arm, press it up into place. Turn the nut 1/8 turn clockwise to make sure the nut locks back into place.

Figure 32. Clean and maintenance in user manual of dishwasher

Depending on the manual, there are different labels used to refer to ‘clean and maintenance’ information, which is the case for this user manual. As shown in figure (32), the manual refers to such information as ‘care and cleaning’ instead of ‘clean and maintenance’. However, regardless of the title used, they represent the same type of information that is how to maintain the product. Shedding more light on the information presented in maintenance, the figure (32) shows that the first sentence is used to explain the importance of taking care of the product. Next, it gives warning to the user before proceeding with the process of cleaning. After that, the instructions of cleaning are provided along with the corresponding visual to give more clarity to the user. Using such visuals is in fact a great help for the user hence without which it may be very difficult to perform such actions particularly if the product has very complicated parts. Therefore, the use of visuals depends on the nature of the product at hand. In other words, there are products that need the use of verbal-visual while others may only need the use of either verbal or visual. Such instances are best shown in the following figures.

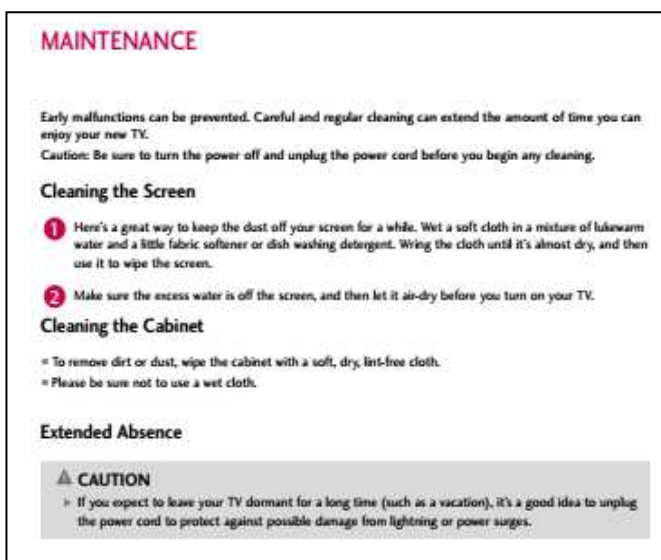

Figure 33. using only verbal to explain maintenance instructions in LCD TV user manual



Figure 34. Using only visuals to explain maintenance instructions in Iron user manual

These figures (33 and 34), namely of LCD TV and Steam Iron, show clearly the use of either verbal (text) or visual to explain maintenance instructions. Thus, although TV is a complicated device it has very simple maintenance steps that are expressed through only verbal. On the other hand, the Steam Iron is a very simple device; however, it has different parts that can be moved for cleaning. Thus, visuals are used to show clearly how to clean such parts.

6.3.Moves unique to service manuals

6.3.1. Audience

The differences between both types of manuals are due to the difference in the types of the audience they address. User and service manuals are addressed to the laymen and technicians respectively. Since they have different categories of audience they are more likely to seek different communicative purposes that are expressed through different moves. However, such differences do not make them completely different; thus, they have also some similarities namely in terms of moves used to convey their intended communicative purposes. Such similarities lead to involve other moves that are unique to each type in order to distinguish them. As a result, service manuals indicate clearly the type of the audience the manual is devoted to. By doing so, they prevent other people, especially the unauthorised ones, from using the service manuals. Therefore, stating the type of the audience in service manuals is to act as warning for nonprofessional or unqualified person. Thus, it implies that the company is not liable to any damages occurring during the repairs. To make it clear consider the following figure that represents samples of specifying the audience in service manuals.

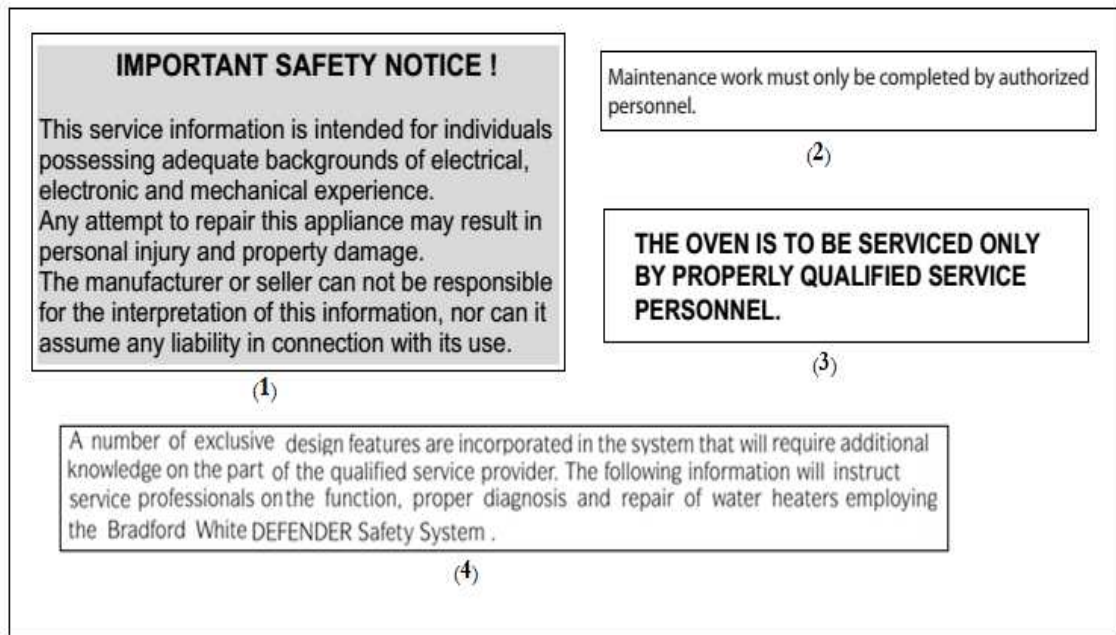

Figure 35. Samples of specifying audience in service manuals

The figure shows four different samples that include information about the audience of service manuals. However, they do not only specify the audience but also give additional information depending on the manuals. This specific feature is shown in sample (1) (figure 35). On the one hand, after identifying the intended individuals for the manuals, it warns unauthorised or unqualified people from the risks of injuries if they attempt to repair the product themselves. In addition, it explains the company's liability in case of misinterpreting the provided information. On the other hand, sample (2) and (3) include only information about the person to service the product, who needs to be one of the authorised and qualified personnel. In Sample (4), the audience is determined by the expression 'service professionals', which indicates that the manual addresses specific individuals with adequate knowledge. Even if the person is a qualified one, he needs additional information provided by the manual due to the product 'exclusive design features'.

6.3.2. Servicing instructions

Similar to operating instructions in user manuals, servicing instructions are the core of the service manuals. They include systematic guidance for the technician to safely and correctly repair the product at hand. Even if the technician is a trained person, servicing instructions serve to support him in his job because products differ in their design and features that he may not be familiar with. Since the manual is also to ensure safety, it provides the necessary precautions that need to be taken into consideration before and during the repairs. In addition, the servicing instructions offer different tests and checkpoints that are more likely to diagnose the source of the problem. Knowing that, the repair process needs accuracy and precisions hence any mistake may worsen the problem. As a result, to ensure that such actions of repairs are performed adequately, the instructions of servicing are expressed through verbal-visual rhetorical function. By doing so, it leaves no room for ambiguity. To give it substance, consider the following.

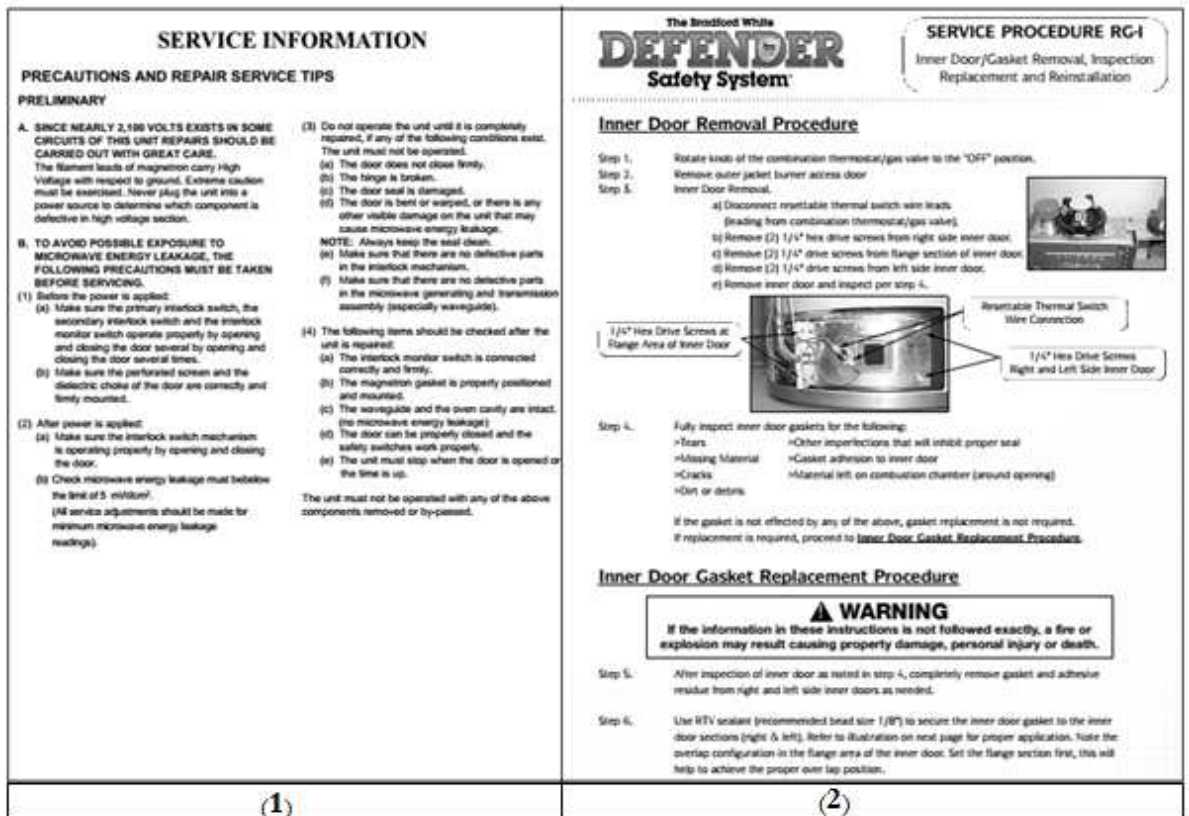

Figure 36. Servicing instructions in microwave and water heater service manuals

Figure (36) represents two samples of service instructions, also referred to as service information. Thus, in sample (1/figure 36), the information includes precautions and service tips, which are expressed through the use of verbal expressions. However, sample (2/figure 36) gives the necessary information directly with steps that are clearly supported with visuals. So, the information for the sample is conveyed through verbal-visuals. Although sample (2/figure 36) does not give precautions right at the beginning, as it is the case for sample (1/ figure 36), it does not neglect the notion of safety. In fact, it provides warning, as shown in the figure, along with servicing instructions. Furthermore, verbal-visuals are used to clearly explain the information of tests and checks needed for diagnosing the source of the problems. The following figure will illustrate the point.







7 COMPONENT TESTING TIPS			
Component	Test procedure	Check result	Remark
1. Thermostat (Manual type) 	Measure resistance of Terminal to terminal 1) Open at 170°C (-10/+5°C)	Measure resistance by pressing button When resistance becomes = Resistance value = 5Ω	Safety Thermostat
2. Thermistor (Low temp.) 	Measure resistance of terminal to terminal	Resistance value : 10KΩ ± 5% (at 25°C)	Cover, Front
3. Heater, Thermistor 	Measure resistance of Terminal to terminal	Resistance value : Yellow/White : 28.96 ± 1Ω Blue/White : 56.29 ± 2Ω	Heater
	Measure resistance of terminal to terminal	Resistance value : 200KΩ ± 5% (at 25°C)	
4. Motor 	Measure resistance of Terminal to terminal	Resistance value : White/Blue : 24.8 ± 2.5Ω Blue/Red : 21.5 ± 2.0Ω	
5. Capacitor 	Measure capacitance of Terminal to terminal	Capacitance value : 10 ± 0.2μF	
6. Pump 	Measure resistance of Terminal to terminal	Resistance value : 205 ± 10Ω	

Figure 37. Testing tips from servicing instructions in service manual of tumble dryer

Although verbal-visuals have a common objective, which is clarifying information, they have different roles in presenting such information. In figure (37), the visuals are used to illustrate the components while the verbal is to explain the procedures of the tests that need to be carried out.

6.3.3. Disassembly instructions

As mentioned before, servicing instructions are the core of service manuals. Their role is to supply the technician with all the required information for safe and correct repairs. With equal importance to servicing instructions, disassembly instructions are of great help in the process of repair. As its name indicates, this kind of

instructions is mainly devoted to explain how to disassemble the product; it is a necessary step in the repairs because the technician needs to examine the internal components so that he can identify the problem and fix it. Although disassembly instructions are presented in service manuals separately, they are in fact a part of servicing instructions. Thus, in case of serious damage the technician cannot service the product without knowing the appropriate way to disassemble it. Knowing that products differ in their design and features, they also differ in their way of disassembly. In fact, disassembly instructions are not only for correct disassembly, they ensure the safety of the product by providing the required techniques and methods to do so. The technician needs to disassemble the product without affecting the internal components. Thus, ignoring such instructions or using force during such a process may lead to breaking some of the components and hence damaging the product at hand. Due to their importance in the repairs, disassembly instructions are explained clearly using verbal-visuals. This assumption is best illustrated in the following figure.

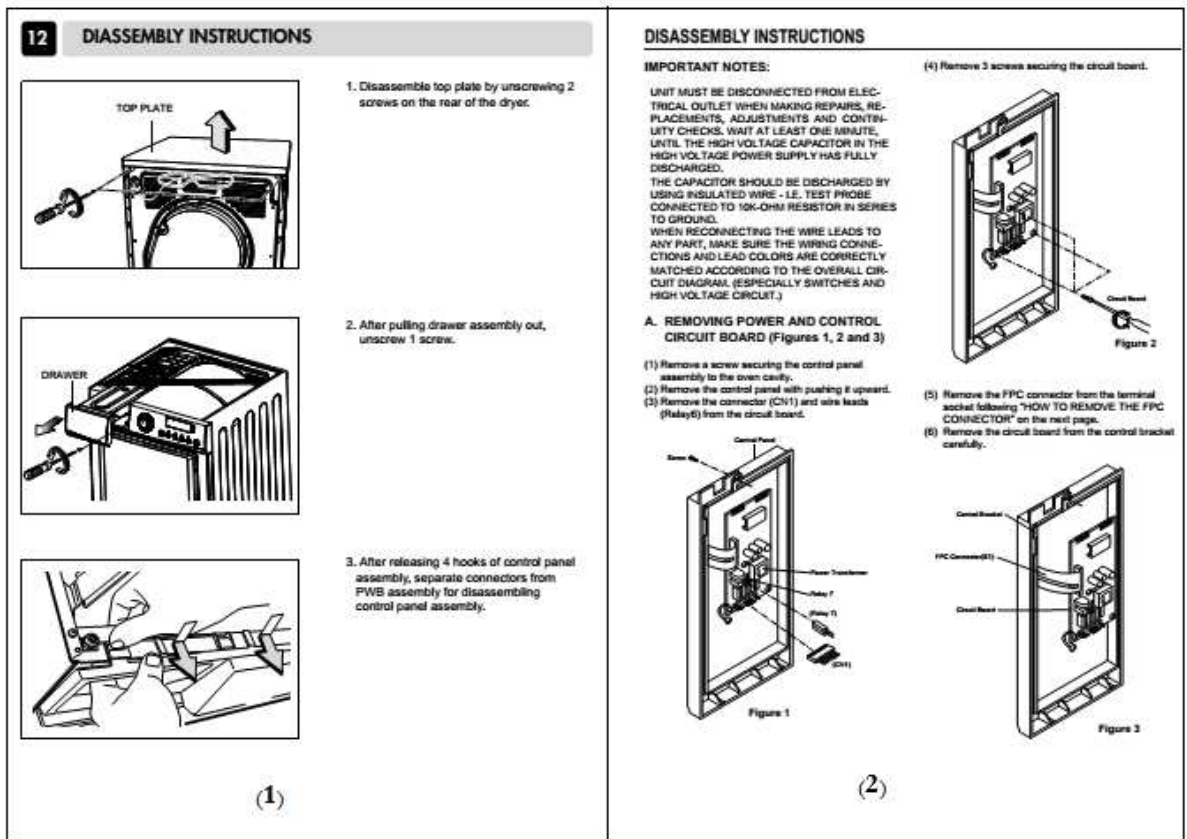

Figure 38. Disassembly instructions in service manuals of tumbler dryer and microwave oven

As shown in figure (38), verbal-visuals are used to convey disassembling instructions. The steps to do so are clearly explained through the visuals that support the verbal (text). Although they are combined together, we notice that there is less verbal used to represent disassembly instructions because visuals tend to communicate more information than verbal does. Therefore, a little explanation using verbal will be enough to the technician hence he can understand what he is supposed to do from the visuals. Such assumption is clearly manifested in sample (1/figure 38). Depending on the manual, more verbal may be used to give more details, which is the case for sample (2/figure 38). In fact, the details given in sample (2) represent precautions necessary for correct and safe disassembly.

6.3.4. Schemas and diagrams

Repairing the product is to know the source of the problem and fix it. Thus, the technician must know the components of the product as well as their interconnections. In many cases, the defects of the product are due to the damage of components or their interconnections. In service manuals, such information is conveyed through schemas and diagrams. They are very useful in the process of repairing because they help the technician to locate the different components within the product. Thus, without schemas and diagrams it is difficult to do so because of the small size of the components. Schemas and diagrams use a set of conventional symbols to represent the different components within the product. Based on his training and knowledge the technician can easily read such symbols.

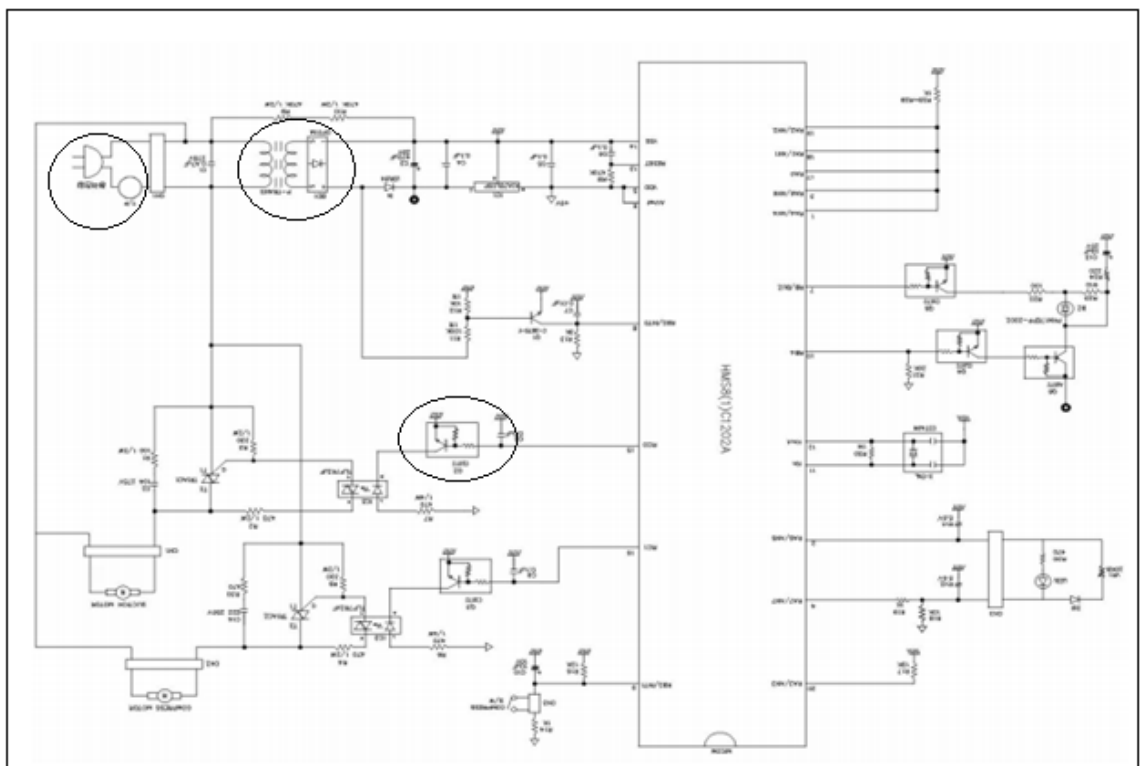

Figure 39. Schemas in service manual of vacuum cleaner

Since schemas are devoted to technicians, they are based on symbols that stand for the components of the product, as it is shown in figure (39). Thus, they are not labelled; that is, there is no use of verbal. They are only expressed through visuals. The latter are drawn using lines and the appropriate symbols. The connections of the lines in the schemas are in fact to show the interconnections of the product's components. In addition to schemas, the service manuals use also diagrams. Although schemas and diagrams serve the same purpose, which is to the technician familiar with the product's component, they are not exactly the same. Thus, while schemas use only symbols, diagrams may use symbols and small drawings known as pictorials. To make it clear, consider the following.

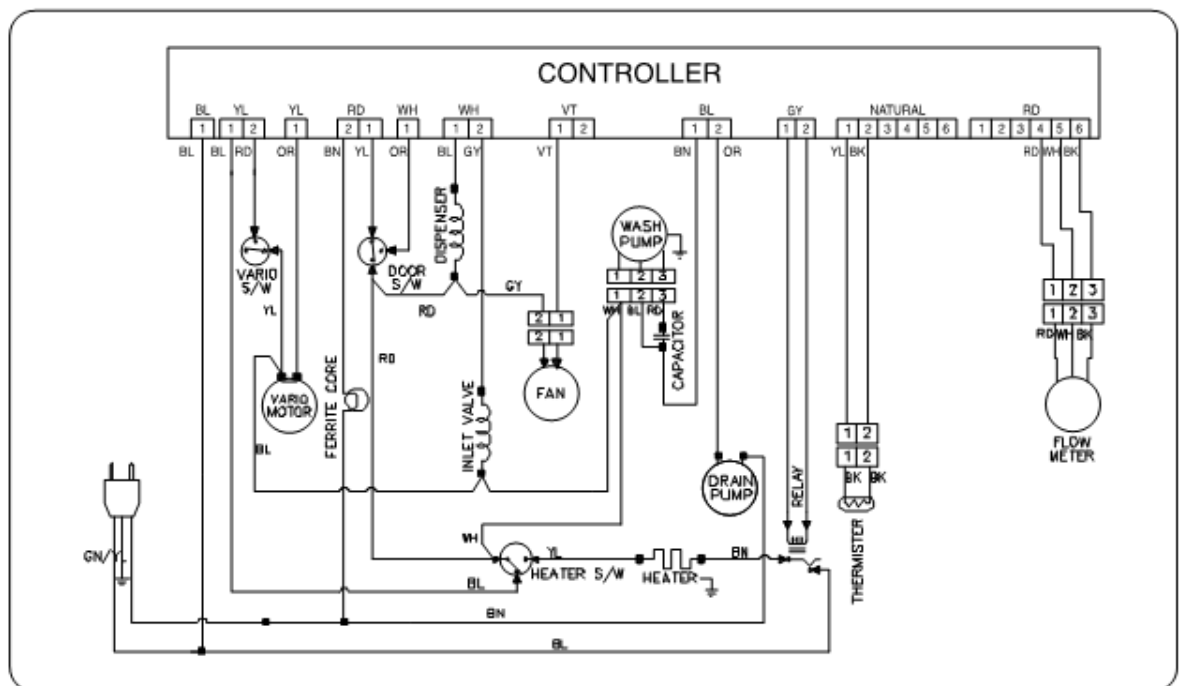



Figure 40. Diagrams in service manuals of dishwasher

Following figure (40), the diagram consists of lines, symbols and pictorials. Furthermore, diagrams involve labels for the represented components. For instance, in figure (40), consider the use of 'fan', 'vario motor', and 'wash pump', just to name some. Instead of symbols, the components names are used within a circle. In similar

way, a pictorial of the electrical plug is used instead of its symbol, which is generally used as . We can notice that diagrams provide a general view in the sense that they give a simplified layout of the components whereas schemas are very specific because they include a detailed representation of all the components using complex symbols.

6.3.5. Exploded view

Since repairs are a complex process that involves different steps to be accomplished, the service manuals provide all the necessary information to help the technician doing his job. One of such information is the exploded view. It has equal importance as schemas and diagrams. However, rather than internal components of the product, it gives a clear image about the different parts used in its construction. This kind of information is expressed through the use of visuals. As its name indicates, it is a view of the product's parts presented using drawings. These parts are illustrated in a similar way to an explosion hence each part is separate from the other ones.

The use of the exploded view is most likely to support the technician during the disassembly phase. Although disassembly instructions include visuals, they do not give a view of all parts together. Thus, the exploded view is more detailed one because it considers all the constituent parts of the product. In addition, it is very useful when reversing the process of disassembly i.e. when the product needs to be assembled. For more clarity, consider the following.

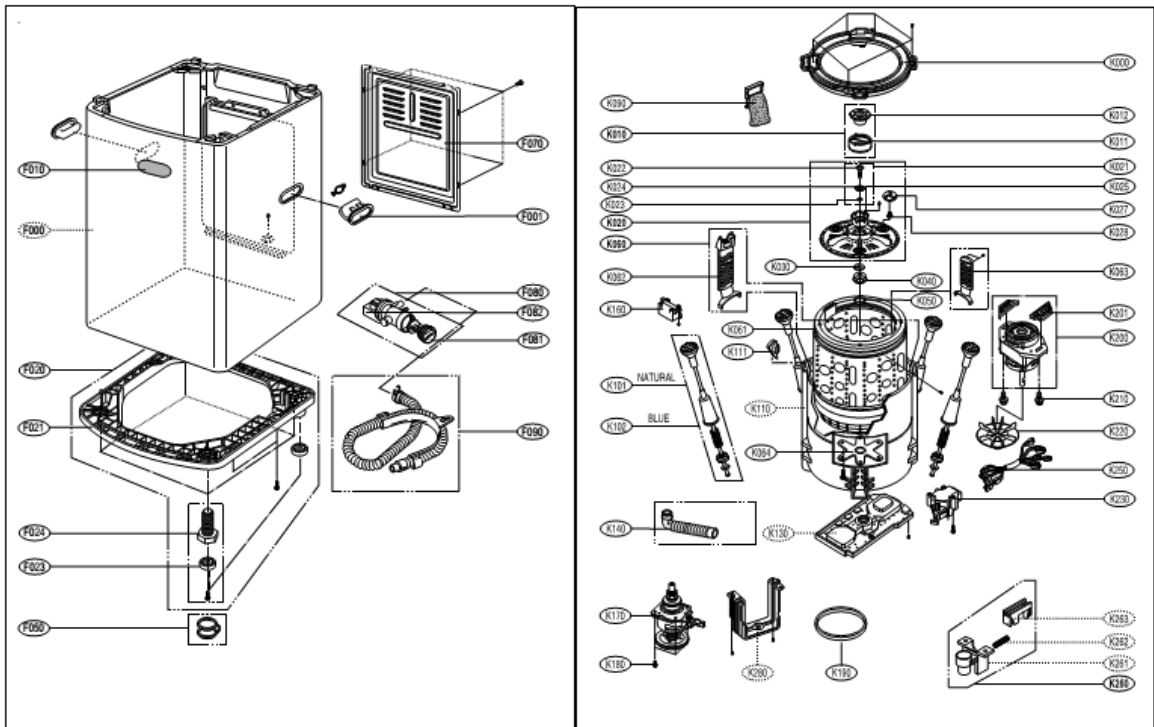

Figure 41. Exploded view in service manual of washing machine

Depending on nature of the product, the exploded view may be presented in many pages. As shown in figure (41), all the constituent parts are considered in the view so that to give clear image about the disassembly and assembly process. The names of the part are not used; instead there are codes that stand for them. The latter are used as a reference for spare parts in case there is a need to replace the defected ones.

6.4. Summary of Results and Findings

The analysis reveals that both manuals, user manuals and service manuals, have a set of moves used to communicate information to the reader, be it layman or the technician. Thus, what they want to communicate determine the types of moves to be used in the manual. In other words, the moves used to structure the manuals depend on the communicative purposes to be achieved. In addition, the audience, to whom the manuals are devoted, is also taken into consideration in selecting the moves that will be used in the manuals. The interference of the audience criterion in determining the moves

is very important hence the manuals must meet the user needs whether they are general or professional. That is, manuals have to fulfil the ‘primary’ communicative purpose for which they were designed. Using the term ‘primary’ implies that there are secondary communicative purposes. In fact, manuals, as an instance of genre, include more than one communicative purpose. Such purposes may not be explicitly stated or easily identified because they are generally hidden within the main or primary one. To make the image clear, the primary communicative purposes of user and service manuals are ‘to instruct the user’; however, in the case of user manuals, it is to instruct him how to operate the product while in service manual it is how to service or repair the product.

Although both manuals may share the purpose of ‘instructing’, they differ in the type of instructions to be conveyed to the user. In fact, the audience determines the type of instructions to be conveyed in manuals. Since both manuals address different types of audience, the type of instructions will differ accordingly. Thus, what applies for one type of audience does not apply for the other. On the one hand, the user manuals intend to provide the user, the layman, with necessary information to operate the product at hand. On the other hand, service manuals are to provide the technician with information that helps him to repair the product. As a result, knowing the audience is very important because it does not only determine the types of moves to be used but also helps identifying the communicative purposes.

Moves are related to communicative purposes in the sense that they serve to accomplish the intended purposes to the user/reader. To put it differently, communicative purposes are expressed through the use of moves. Thus, knowing the purposes to be achieved helps to assign the appropriate moves. That is, which move is suitable for a given communicative purpose? Therefore, the moves mainly used in the case of user and service manuals are mostly used to achieve the primary communicative

purposes, mentioned earlier, which are ‘to operate’ and ‘to service’ respectively. However, the assigned moves in both manuals do not only express the primary purposes but also the secondary ones generally hidden under the primary purpose. To give it substance, as secondary purposes, the manuals include warnings which notify the user of potential danger that may hurt him or damage the product. Such warnings are very important because, on the one hand, they save the user and the product. On the other hand, they save the company or manufacturer a lot of money in case the user does not comply with the instructions of warnings, which make the company not reliable to any compensation if the product is damaged of misuse on the part of the user.

Manuals, user or service ones, as a typical kind of genre are designed to communicate a given piece of information to the user. Thus, they are the communication channel / bridge/ link between the manufacturer and the end-user. In order to establish such a bridge three elements are needed including audience, communicative purposes and moves. These elements are interrelated because one helps to determine the other. Such relationship can be illustrated using the following diagram.

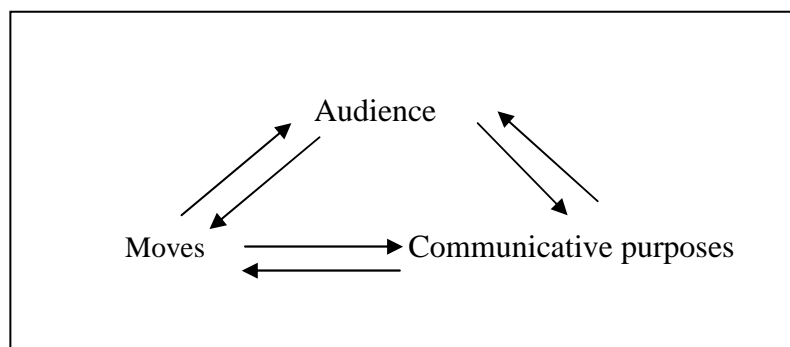

Figure 42. Interrelated relationships of audience, purposes and moves

The relationships of the three elements are explained in the diagram using the arrows forward and backward. First, the audience determines the communicative purposes to be fulfilled because each type of audience needs different communicative purposes. Thus, in user and service manuals, they differ according to the audience since they represent general and professional audience respectively. Second, knowing the communicative purpose to be achieved is an important step to determine what moves are going to be used in the manuals. In this respect, the audience is indirectly contributing to determine the moves needed to structure the manuals.

On the other hand, the use of the backward arrow is to reverse the process in case of analysing the manuals genre in terms of these three elements. That is, the analysis of moves can lead to determine the nature of the audience and also helps to identify the communicative purposes assigned for such moves. In similar way, analysing communicative purposes is more likely to reveal the intended audience and the moves through which these purposes are expressed.

In what follows a comparison between the identified moves in the user and service manuals is presented in order to determine the moves used in both types of manuals. In addition, it helps to determine the shared moves and the unique ones that characterise these manuals. In other words, by comparing the moves from both manuals similarities and difference can be identified easily.

6.4.1. Comparison of moves in user and service manuals

The results of comparing both types of manuals in terms of moves show that they have unique and common moves. The unique ones are to differentiate the two types from each other. In addition, these unique moves represent in fact the differences in the two types. Such differences are affected by two factors including audience and communicative purposes. Since both types have different audience, they are more likely to use different moves that go with the audience needs. Furthermore, different moves imply different communicative purposes hence the latter is expressed using moves. Thus, user manuals are devoted to the general public or layman. Their primary purpose is to give instructions about operating the product at hand. These moves structure the user manuals to achieve their primary purpose. In spite of that, user manuals are also designed to fulfil other purposes. Such purposes are to be classified as secondary purposes because they are not the main concern of the manual. Such purposes are identified and expressed through the unique moves that characterise user manuals, as shown in table (46).

Unique to user manuals	Shared moves	Unique to service manuals
<ul style="list-style-type: none"> - Thanking the customer - Maintenance - Warranty 	<ul style="list-style-type: none"> - Read the manual - Safety instructions - Installation instructions - Operating instructions - Troubleshooting 	<ul style="list-style-type: none"> - Audience - Servicing instructions - Disassembly instructions - Schemas and diagrams - Exploded view

Table 46. Shared and unique moves of both types of manuals

Therefore, thanking the customer, in user manuals, clearly reveals the intention of selling hence it is one of the strategies used in marketing. It seeks to build confidence in the customer towards the company products. Using such move is also to make him satisfied with his choice because being thanked leaves the impression that you made the right decision. In addition, maintenance, as unique move for the user manual, indicates the purpose of maintaining the product. It tends to expand the product lifecycle as it maintains its good performance. That is, regular check and cleaning help to keep the product in service for long period. In other words, checking the product regularly is useful to detect problems right at the beginning before they develop to serious ones.

In addition, cleaning prevents any dirt to accumulate which usually interfere with the product performance. Knowing that, maintenance is for the customer benefits. However, it also serves the company well. Thus, providing such information to the user/customer reduce the possibility of having problems with the product which in given circumstances make the company spend some money. In fact, the occurrence of such problems during the guarantee period make the company pay for compensation or repairs service. So, in order to explain to the customer what are the appropriate circumstances under which the company is to pay for compensation or repairs, it uses warranty as a move to convey such purpose. Depending on the company, the design of the manual warranty may not be included within the manual itself but still it is provided separately within the product package.

Taking into consideration user manuals primary purpose, the moves used to achieve it tend to be the shared ones. That is, the moves shared between the user and service manuals, indicated in table (50), serve to accomplish the main purpose of user manuals, which is instructing the user about operating the product. Asking the user/reader to read the instructions and maintain them for future reference is the first move to make him

consider instructions before operating the product. Operating the product, in some cases, may involve some risks that can cause injuries or damage to the product. Thus, to ensure safe operation for the user and the product as well, the manuals express such purpose using safety instructions. Sure enough, without appropriate installation the product is unlikely to operate correctly. One important step towards operating the product is through good installation: such purpose is achieved through installation instructions. Once the product is correctly installed, the user can start its operation following the different operating instructions devoted for such purpose. However, even following operating instructions, problems can occur during operation. To deal with such problems, troubleshooting gives the possible solutions to fix them.

With that being said, operating the products is achieved through different moves that guide the user towards such purpose. In fact, these moves make him go through different stages, before, during and after he reaches his purpose, which is operating the product. Therefore, asking him to read the instruction, giving safety instructions, and correct installations serve to prepare him to operate the product. This is the reason why they come before operating instructions. However, even achieving the purpose of operating another move is used to secure such purpose. Thus, troubleshooting, that is presented after operation, is to fix the problems that may interfere with the product performance. Following this assumption, it becomes clear why the first move also asks the user to maintain the manual for future reference. It is due to the fact that the user needs troubleshooting information in case there are problems with the product.

Although service manuals share some moves with user manuals, they are not used to convey the same communicative purposes. Thus, for service manuals the primary purpose is not operation of the product but rather service or repairs. Therefore, even the shared moves with user manuals are to achieve such purposes. In addition,

unlike user manuals, the moves that serve the main purpose of service manuals tend to be within the unique moves, as indicated in table (50). Although the shared moves are also to support such purpose, they are not as important as the unique ones. Knowing that the audience for this kind of manuals refers to the technician who is regarded as a professional person, the moves used in the manual is to support and guide him to achieve his purpose of repairing the product at hand. Therefore, the communicative purposes expressed through the shared moves differ from those of user manuals. That is, asking the user, who is in this case the technician, to read the manual is not simply to be able to operate it but to perform safely and correctly the necessary repairs. Regardless of the technicians' experience, safety must be ensured during the repairs.

Installation and operation instructions are in fact to help the technician to identify any problem that affects the product. In other words, he needs to know the correct installation and operation in order to be able to determine whether the problem lays in the installation itself or in the operation of the product. Thus, checking these two points can be considered as the first stage of repairs. Unlike user manuals, troubleshooting for service manuals is to diagnose the source of the problem. It is not about problem-solution as it is the case for user manuals but rather it follows a systematic way through the use of chart. The latter includes different problems for different parts of the product. The problems are presented as questions, and in some cases through declaratives. The appropriate way to fix the problem is expressed using the imperative.

Given that repair needs a qualified person, service manuals warn the other users who are not authorised or not qualified to repair the product themselves. By doing so, they clearly specify the type of the intended audience. Presenting such information frees the company from any liability if the reader is to ignore it. In addition, due to its

importance, this information is generally stated within safety instructions. The reason behind this is that there are many risks, particularly electricity shocks, which in many cases lead to injuries or even death. In addition, safety is also concerned with the product hence any inadequate repairs can lead to its damage. Thus, to avoid any risks or damage, the manuals provide the required instructions for repairs through different moves. Why so? Because repairs is a process that needs different steps to be accomplished. These instructions are what distinguish service manuals from other types of manuals. They serve clearly the primary communicative purpose of the manual. Therefore, servicing instructions tell the technician how to proceed during the repairs.

In addition to troubleshooting, which appears as a shared move, disassembly instructions explains how to disassemble the product so that to reach the internal components. This information is supported by other moves namely schemas and diagrams and exploded view. Once the product is disassembled, the schemas give the technician a clear image about the components and their interconnections. The exploded view is to provide a visualised image about the different parts of the product so that to help him in the process of disassembly and assembly.

For a better representation of the moves, namely the shared ones, they are further considered in terms of their linguistics features. Thus, the analysis of lexis and sentence types can reveal whether both types of manuals use the same lexis and sentence types or not. In what follows, the results obtained from the analysis of moves in both types of manuals in terms of lexical sets and sentence types are comparatively presented in tables 49 and 50 respectively.

Moves identified		User manual	Service manual
Read the manual	<i>Common words</i>	81.86	81.82
	<i>Academic</i>	11.40	10.39
	<i>Tech words</i>	6.74	7.79
Safety instructions	<i>Common words</i>	81.65	78.88
	<i>Academic words</i>	4.76	6.82
	<i>Tech words</i>	13.59	14.30
Installation instruction	<i>Common words</i>	77.34	76.70
	<i>Academic words</i>	6.26	6.35
	<i>Tech words</i>	16.40	16.95
Operating instructions	<i>Common words</i>	79.64	74.02
	<i>Academic words</i>	6.77	9.87
	<i>Tech words</i>	13.59	16.11
Troubleshooting	<i>Common words</i>	78.20	71.62
	<i>Academic words</i>	5.17	7.52
	<i>Tech words</i>	16.63	20.86

Table 47. Lexical sets of the shared moves between user and service manuals

6.4.2. Lexis of shared moves in user and service manuals

The table shows a comparison of the shared moves according to lexical sets. The latter indicates clearly the nature of vocabulary used to express such moves. Each type of lexical sets is presented in the table as a percentage to show how much these types of vocabulary are used to convey the shared moves.

Based on the analysis of vocabulary profiler, the vocabulary involves three types of lexical sets, which are common words, academic words and technical words. The proportion of each lexical set differs from one move to another. Thus, in the first shared moves, which is ‘read the manual’, the proportion of use of common words in both types of manuals is alike. The same thing can be said for academic and technical words with a slight difference. That is, the use of academic and technical words is slightly higher in service manuals than in user ones.

Unlike the first moves, the use of common words to express ‘safety instructions’ differs in both types of manuals. They are used in safety instructions of user manuals more than those in service one, which is clearly shown in the table as 81.65% vs. 78.88% respectively. However, it is not the case for academic and technical words hence they tend to be higher in service manuals rather than in the user ones. More particularly, in service manuals, ‘safety instructions’ include 6.82% of common words while user manuals use only 4.76%. In addition, technical words show 14.30% of use in service manuals as opposed to 13.59% in user manuals.

The move of ‘installation instructions’ seems to be expressed using the same proportion of the identified lexical sets in both manuals. With reference to the table, although common words show a slight difference, which is represented by 77.34% for user manuals and 76.70% for service ones, academic and technical words mark the same proportion of use, which appears as 6.26% vs. 6.35% and 16.40% vs. 16.95% respectively.

Moving to ‘operating instructions’, the difference between the two types of manuals is gradually widened. The use of common words, which is 74.02%, in service manuals is less than that of user manuals, which is 79.64%. On the one hand, such difference is also noted in academic and technical words. Respectively, they represent 6.77% and 13.59% of the words used in operating instructions. On the other hand, service manuals use 9.87% and 16.11% of the academic and technical words to convey such instructions.

The difference in lexical sets between the two types of manuals is more widened when they are used to express ‘troubleshooting’ instructions. While the vocabulary of troubleshooting involves 78.20% of common words, 5.17% academic words and

16.63% of technical ones, service manuals express the same move using different proportion of the lexical sets including 71.62% of common words, 7.52% of academic words and 20.86% of technical ones. Thus, due to difference in the audience they address, the vocabulary that constructs troubleshooting in service manuals shows significant increase in the use of academic and technical words. However, they decrease in user manuals. However, common words are to decrease in service manuals and increase in user ones.

In sum, the lexical sets that build the vocabulary for each moves depends, first on the types of the manual and, second, on the type of move itself. Moving from general to very specific moves, the lexical sets change accordingly. Thus, moving from 'read the manual' to 'troubleshooting', common words tend to decrease in their proportion of use namely from 81.86% to 78.20%. In fact, this assumption does not only apply to user manuals, but also to service ones hence the common words decrease in their moves from 81.82% to 71.62%. In addition, the type of manual also influences these types of words because they are more used in user manuals than the service ones. In addition, academic words show a variety of proportion's use regardless of the move and the type of manuals. Unlike common words, they do not show consistent increase or decrease which means that they vary from one move to another and from one manual to another. Technical words tend to be more consistent in their use through the moves as well as the types of manuals. That is, they increase from general move, as 'read the manual', to more specific one as 'troubleshooting'. In like manner, their use changes from user manuals to service ones. More particularly, in user manuals technical words increase their rate of use from 6.74%, used in 'read the manual', to 16.63%, which represents 'troubleshooting'. Thus, we can say that their use is not bound to the type of moves alone but also to the type of manuals. That is, technical words are more used in service

manuals than user ones. Additionally, they increase in specific moves as ‘troubleshooting’ and decrease in more general ones; their rate of use increases from 7.79%, in ‘read the manual’, to 20.86%, which refers to ‘troubleshooting’.

As we already mentioned, the type of the move and the manual play an important role in determining the use of lexical sets, particularly those of common and technical words. The difference between the two types of manuals is clearly shown when considering the average of use for each type of lexical sets. The following table illustrates the point.

Lexis of shared moves	User manuals	Service manuals
Common words	79.73	76.60
Academic words	6.87	8.19
Technical words	13.39	15.20

Table 48. Average of the lexis used in the shared moves

The above table shows the average of using each lexical set in both types of manuals. The average of using common words in all the shared moves in user manuals is 79.73%. Academic words have an average of 6.87%. Technical words are also a part of the vocabulary that builds the identified moves; in user manuals they are used with an average of 13.39%. Service manuals express such moves using different proportion of the lexical sets. Thus, common words have an average of 76.60% that shows the presence of such words within the moves’ vocabulary. Academic words mark their presence with an average of 8.19%. As an average of use, technical words have 15.20% of the words used to convey such moves. We can then say that the type of the manual makes it clear that these lexical sets differ in their average of use, moving towards more specific type. Thus, in case of common words their rate of use decreases considerably when used in service manuals. However, it is not the case for technical words, which

rather increase in such manuals. As a result, the more specific the type of the manual, the less common words will be involved and the more technical words are to be used.

Since these lexical sets are used in the shared moves, they do not convey information on their own but they construct sentences through which instructions are conveyed. Therefore, it is worth considering such sentences that communicate the moves to the user/reader. The following table gives clear image about the sentence types representing each of the shared moves.

Moves identified	Sentence Type	User manual	Service manual
Read the manual	<i>Imperative</i>	14	7
Safety instructions	<i>Imperative</i>	167	213
	<i>Declarative</i>	67	117
	<i>Conditional</i>	13	28
Installation instruction	<i>Imperative</i>	87	83
	<i>Declarative</i>	34	69
	<i>Conditional</i>	11	11
Operating instructions	<i>Imperative</i>	175	86
	<i>Declarative</i>	154	248
	<i>Conditional</i>	39	19
Troubleshooting	<i>Imperative</i>	303	623
	<i>Declarative</i>	334	400
	<i>Conditional</i>	28	31
	<i>interrogative</i>	22	208

Table 49. Sentence types of shared moves in user and service manuals

The table shows the different sentence types that characterise the moves and their frequency of use. The identified sentence types, including imperative, declarative, conditional and interrogative, depend on the nature of the move. Thus, in the first move, which is ‘read the manual, the table shows only the use of imperative because it is the only sentence type used to express such move. In addition, the frequency of the imperatives provided by the table is to refer to the occurrences of this move; hence, each imperative sentence represents one occurrence in a manual.

Safety instructions include a variety of sentence types with more prominence to the imperative, which represents 167 sentences of safety instructions. Declarative sentences show their presence in safety instructions through 67 sentences while conditionals express only 13 sentences. Knowing that, service manuals involve the same sentence types for the shared moves; however, they differ in the frequency of use. Thus, the imperative as a prominent sentence type is used 213 times. Declaratives show their significance in this move as they represent 117 sentences of safety instructions. Conditionals' frequency indicates that they are less used since they only appear in 28 sentences.

Such frequencies of use, for the identified sentence types in both types of manuals, reveals that in service manuals the gap between imperatives and declaratives is narrower than that of user manuals. This finding implies, on the one hand, that safety instructions in service manuals are expressed mostly through the imperatives and declaratives. On the other hand, considering the gap between imperatives and declaratives in user manuals, such move is mainly expressed through the imperatives. Such gap appears when considering imperatives and declaratives for both types of manuals, such as (167), (67) and (213), (117) referring to user and service manuals respectively.

The same thing can be said about the next move, which represents installation instructions. Giving more prominence to the imperatives, both types of manuals use imperative and declarative sentences with the following frequencies (87), (34) and (83), (69). Again, the gap between such types of sentences is narrower in service manuals. However, it seems that such assumption does not apply for the move representing operating instructions because in this case the gap is narrower in user manuals instead of service ones. There is a little difference in terms of frequency between the

imperatives and declaratives used to convey operating instructions. Moreover, in service manuals such instructions are mainly expressed through declaratives making them the prominent sentence types. Thus, while imperatives occur in 86 sentences, declaratives are to represent 248 sentences.

Unlike the previously discussed instructions, troubleshooting reveals the use of additional sentence types that do not occur in other types of instructions. Interrogatives give more diversity for the instructions used in this move. Although their use is not significant as other types, they appear as (22) sentences in user manuals, and (28) sentences in service manuals; they are necessary due to the nature of troubleshooting instructions. On the contrary to operating instructions, user manuals give more prominence to declaratives, consider (303 imperatives) and (334 declaratives), rather than imperatives. Service manuals include more imperatives representing 623 occurrences compared to 400 occurrences for the declaratives. Still, the gap between these sentence types is narrower in user manuals rather than service ones.

Although user and service manuals differ in their primary communicative purpose, their intended purposes are to instruct the user about ‘operating’ and ‘servicing’ respectively. Both types of manuals are shaped with a number of moves that help to achieve such purposes. Just as these moves serve the primary purpose for each type of manuals, so do the communicative purposes conveyed through them. In spite of the difference that appears in the primary purpose of both types of manuals, they share some of the moves used to structure both types. Other moves are to characterise the manuals hence they are unique to each type of manuals. However, using the same moves does not mean they share the same communicative purposes. As a matter of fact, the shared moves between the types of manuals differ in their intended purposes. For instance, as has been noted previously, while user manuals use troubleshooting to solve

minor problems that may face the user through suggested problems and solutions, service manuals use it to identify the source of the problem, generally a serious one, and how to fix it hence it is the primary concern of such type of manuals.

In terms of lexical sets that represent the vocabulary of these shared moves, both types of manuals show different distribution of lexical types as moving from general to specific within the moves; they differ according to the type of the manual i.e. moving from user to service ones. Thus, common words in user manuals show a gradual decrease when used in more specific moves as troubleshooting. The same thing can be said for service manuals. However, technical words are not only to increase in specific moves but also according to manual type. Thus, in service manuals they increase significantly.

Such moves are not expressed through vocabulary as such but through sentences constructed using different lexical sets. To convey the intended information of such moves, they use different sentences types including imperatives, declarative, conditional and interrogative. Their frequency depends on the nature of the move as well as the type of the manual. Therefore, taking this into account, the prominent sentence types are imperatives and declaratives. In user manuals, imperatives are the prominent ones except in troubleshooting where there is prominence of declaratives. On the other hand, service manuals use the imperative in troubleshooting and so for the other moves except operating instructions, which is mainly conveyed through the declaratives. As a result, each type of manuals expresses the move that is essential to their primary purpose through the imperatives and the secondary one through the declaratives. In other words, user manuals express operating instructions, which are directly linked to the primary purpose of the manual, through imperatives, while service manuals convey it through declaratives hence it is not directly linked to their primary purpose, which is 'servicing

the product'. However, they express troubleshooting, which is significantly used to achieve the primary purpose, through the imperatives. Contrarily, in user manuals, they are expressed through declaratives since they do not serve directly their primary communicative purpose.

6.5. Discussion according to research questions

6. Is it possible to address the professional users/readers with the same genre used for non-professionals?
7. Would they recognize this communicative event as a genre even if they do not belong to the same community members? (non professionals).
8. Do user manuals devoted to the layman have the same communicative purpose as those used to address the professional users as technicians?
9. What kind of genres can we have when there is a change of the communicative purposes?

6.5.1. Questions one and two

Taking into account the similarities and differences in both types of manuals, professional users as trained individuals with adequate knowledge based on experience and conventions, they are more likely to understand user manuals and recognize them easily based on the shared conventions that shape such manuals. The shared conventions represent in fact the shared moves between the two types of the manuals. The value of the shared moves differs according to the type of the manual and hence according to the types of the audience. That is, the identified shared moves for non-professionals are very important ones because they fulfil directly their needs that lies in operating the product. However, considering different types of manuals as service manuals, these shared moves are perceived differently in the sense that they are not of

primary concern to the professional users because they do not serve directly their needs, which are to repair the product.

Such differences in perceiving the importance of the moves in professional and non-professional manuals is not only restricted to the shared moves. This assumption is also true for the unique moves that distinguish each type of manuals. Thus, while the unique moves for user manuals, or non-professional, may seem of less importance because they are not related to their primary purpose, in service manuals they are of crucial importance because of their relation to the primary purpose of the manuals, which is repairing the product.

In this regard, the professional can recognize user manuals because they are in a sense a part of the service manuals, which makes them already familiar with such moves. In addition, it is more likely easy to move from specific to more general than from general to specific. That is, in comparison to user manuals, service manuals are more specific. Thus, non-professionals will have more difficulty if they try to deal with service manuals. However, they still can recognize a part of the service manuals namely the one that includes the shared moves as safety instructions, installation instructions and operating instructions. Therefore, even within the service manuals, there is a general part represented by the shared moves though the specific one is represented by the unique moves.

6.5.2. *Question three*

Regardless of the nature of the moves, shared or unique, user and service manuals both use such moves to convey a number of communicative purposes that meet the needs of the audience whether professional or non-professional. Thus, the analysis of moves is also meant to reveal the communicative purposes behind them. Knowing

the communicative purpose is an important step to know the intentions of using such moves to shape the genre of user and service manuals. The communicative purposes in user manuals include selling, hedging, instructing (installation and operating), maintaining, and guarantee. In service manuals, the communicative purposes involve hedging, instructing (installation and operating), and repairing.

Clearly, selling is the first communicative purpose that marks the difference between the types of manuals. Such purpose is conveyed through the second move, which is 'thanking the customer'. However, in service manuals, such move is not used at all because the technician does not play a role of a customer, he is only to repair the product as part of the company's service. Thus, in user manuals, readers are potential customers that make the company gain more profits. In service manuals, the readers are the technicians that repair the product. These technicians can be members of the company's staff. Therefore, the company has no intention of winning more technicians as it has for customers.

Moreover, maintaining the product is an intended purpose that serves to reduce the company's expense. That is, making the user aware of maintenance procedures is more likely to keep the product in a good state for a long period including the guarantee one. Service manuals do not share such purpose because they are used to repair a defected product and it is the responsibility of the customer to maintain the product so that to prevent problems from occurring. Guarantee as a purpose depends on the company design of the manual because it must be presented to the customer but not necessary within user manuals. The purpose behind guarantee is to make the customer aware of the terms under which the guarantee is valid. Therefore, it protects his rights following the customers' law. On the other hand, repairing is unique to service manuals because user manuals do not intend to serve such purpose; even if they include

troubleshooting instructions they do not mean to repair the product as such but to solve minor problems, which is in fact also a part of maintaining the product.

In spite of the differences that show the audience needs and distinguish the two types of the manuals, they share some of the communicative purposes. Both types of manuals ensure safety whether for the user, be it layman or technician, or the product itself. Since safety comes first, the manuals provide safety instructions right at the beginning. Moreover, user and service manuals give instructions about the product that include installation and operating. However, in this regard there is a difference in the intended purpose for giving such instructions. Thus, while in user manuals they intend to make the user handle the product correctly, in service ones such instructions are to support the technician to repair the product because he needs first to know the appropriate installation and operation, particularly in case of new designed products.

In essence, user and service manuals do not have the same communicative purposes. Even though they share some of the purposes that are communicated through the manuals as safety, they differ mainly in those that are directly related to the nature of the manual as selling, maintain and repairing. In fact, such purposes define the nature of the manual whether user or service. Additionally, although both types of manuals involve different set of purposes they are all put under the umbrella of their primary purposes, which is operating for user manuals and repairs for service ones.

6.5.3. *Question four*

Communicative purposes are very important elements in genre analysis because they give a clear image about what writers of such genre want to communicate. They also serve as criteria for identifying and classifying genre. Many scholars in the field of genre analysis including Swales (1990) and Bhatia (1993), just to name a few, adopted

this view. As Swales (1990) argues, “a privilege criterion that keeps the scope of genre”. In addition, considering communicative purpose as the primary determinant of genre membership makes Bhatia believe that a change in communicative purpose of genre is more likely to give birth to a new genre.

Following such assumption, user and service manuals would belong to different genres due to the difference in their communicative purposes. However, the analysis of these types of manuals revealed they are not quite different; hence, they have shared moves that structure and shape them. Sharing moves implies that there are also common communicative purposes between the two types of manuals. Furthermore, it is hard to say that they belong to a particular genre based on communicative purpose only. In fact, the types of manuals involve more than one communicative purpose; they rather entail multiple purposes hidden along the primary purposes. In fact Swales (1990) himself states the difficulty that lays in using communicative purpose hence he claims that the term is ‘slippery’. Therefore, a change in communicative purpose is not likely to lead to the emergence of new genre. Knowing the ‘slippery’ nature of the term, it is very difficult to assign membership based only on such criterion otherwise many text types that share the same communicative purpose will fall under the same genre. Bhatia’s model of promotional genre is the best example for such view, following him job applications and promotion letters is more likely to belong to the same genre hence they have the same communicative purpose of ‘promoting’.

Thus, to cope with such difficulties of identifying genre membership, it is very useful to consider other criteria other than communicative purpose as content, form and intended audience. Considering these criteria gives a better image about the true nature of genre. Although Swales was strongly in favour of communicative purpose, he also stated those criteria as “in addition to purpose, exemplars of a genre exhibit various

patterns of similarity in terms of structure, style, content and intended audience” (Swales 1990:58). As a result, user and service manuals, based on these criteria, are not completely different to the point of regarding them as different genre. Although they differ in the intended audience, they have common grounds in term of form and to some extent content.

6.6. According to Hypothesis

A change in the discourse community members will lead to a change in the communicative purposes of the communicative event. In other words, user manuals will have different communicative purposes by changing the community to which they are addressed.

Although communicative purpose has a significant importance within genre analysis particularly for those who based their views on the functional approach that attributes genre membership according to the communicative purpose, it does not give a clear-cut identification of genre. However, it is useful to know writers’ intentions because communicative purposes are what they want to achieve through their piece of writing. In addition, among these intended purposes lies the needs of the audience they are writing to. Thus, genre is not developed based on personal intentions of the writers but because they communicate given piece of information that fulfil the intended audience needs. As a result, audience plays an important role in determining some of the communicative purposes to be accomplished by the genre in question. The use of the words ‘some’ in the previous sentence implies not all the communicative purposes are identified due to the audience because some of them can reflect the writers needs or intentions as in the case of user manuals. Thus, ‘thanking the customer’ represents the willing of the company to win more customers and hence reveals its intention of selling.

However, 'instructing' the user about the product in terms of installation and operation refers to the needs of the audience to learn how to use the product correctly.

As audience varies from general public to very specific communities, its impact is reflected in the content form and style of the genre. As far as user and service manuals are concerned, the nature of their audience is clearly marked through the types of moves used to structure the genre of such manuals. In service manuals, the nature of the audience requires high frequencies of technical and academic words and lower frequencies in common words. User manuals show at the level of lexis the use of technical words although they are to address the general public. However, it does not affect the fact of being designed to meet the needs of the layman. Shedding more light on audience, user manuals have a larger audience in the sense that technicians can also belong to such an audience. For service manuals, audience is very specific and limited hence it refers only to technicians. The reason for considering even technicians to belong to general and specific audience because they are in this regard as members of two different discourse communities. Therefore, dealing with the audience is also to entail discourse community. Since audience and discourse community are related, it is implied that the change in genre at the level of communicative purpose can be justified by the change in the discourse community. In other words, such assumption can be hypothesized as:

A change in the discourse community members will lead to a change in the communicative purposes of the communicative event. In other words, user manuals will have different communicative purposes by changing the community to which they are addressed.

With reference to the results of analyzing user and service manuals, the hypothesis is confirmed hence there is a noticeable change in the communicative purposes. However, difference in communicative purposes does not necessary entail different conventions. Thus, although user and service manuals are addressing different audience and belonging to different discourse communities, they show to some extent common conventions particularly at the level of the moves. So, discourse community members of both types of manuals can recognize such conventions hence they belong to their shared knowledge. Thus, both sides of discourse communities for instance expect the manuals to include information that explains safety, installation, operating and troubleshooting. Other conventions are unique depending on the types of the manuals and the discourse community within which they occur. Taking troubleshooting as an example, the conventions used to present this kind of information differ in that for user manuals trouble shooting is provided through a table that includes the ‘problem’, ‘possible cause’ and ‘suggested solutions’. In service manuals, however, the conventions used are to present such information through a chart, which helps the technician to identify the problem using questions and answers through ‘yes’ and ‘no’.

While it is true that discourse community can affect the communicative purposes of the genre in question, it is not likely to affect its category. That is, each discourse community has its conventions and goals that are shared by its members. Changing discourse community implies dealing with different conventions and purposes. However, even the resulting communicative purposes are different due to discourse community, they do not mean necessary a completely different genre. This assumption is to answer the second part of the hypothesis that includes:

In turn, changing communicative purpose will lead to the emergence of new genre because the moves used to convey them will be affected and hence the structure of the genre.

In other words, although there are different communicative purposes due to the fact they belong to different discourse communities, the emergence of new genre is not guaranteed in the sense that differences in communicative purposes do not mean surely different genres. In addition, a change in such purposes is not to involve different moves that affect the structure of the genre. As discussed earlier, the results obtained from analyzing user and service manuals revealed that the shared moves could serve different communicative purposes. In this regard, communicative purposes do not have direct influence on the structure of the genre as such. Thus, unless there is a major change at the level of the moves and accordingly at the level of communicative purposes, it cannot be said for sure that a new genre is emerged. Under those circumstances, the second part of the hypothesis is to be disconfirmed.

On the whole, user and service manuals, as a particular kind of genre, they show similarities at various levels including, moves, lexis, and sentence types. Accordingly, they fall within the same genre. In this case, the category of genre that can describe the nature of these two types of manuals is macro-genre. In fact, such classification is attributed following Martin's (1994) notion that genre is a "staged goal oriented activity". That is, genre is moving from beginning to end through a number of stages. With reference to the results obtained from the analysis, user and service manuals realize clearly such assumption. Thus, both of them show different stages that the user/reader go through so that to achieve the defined goal. In addition, user and service manuals also manifest multiple communicative purposes that reflect sub-genres. That is, following Martin's notion, warnings and instructions can be regarded as genre on their

own. Although user and service manuals represent the same genre, service manuals show more typicality hence they address specific audience represented by technicians. However, the moves and linguistic features that they share with user manuals show clearly that even within the professional field the information is structured moving from general to very specific. The first stages of service manuals are realized through moves shared with user manuals. To put it differently, user manuals are present within service manuals through the shared moves. Thus, they are embedded in service manuals.

For this reason, Bhatia (1997) introduced the term genre mixing and embedding to describe such phenomenon. Thus, user manuals generic values are in fact to reinforce the communicative purposes of service manuals. This kind of hybrid genre is created due to society needs. More particularly, they are created to cope with advancement in science and technology fields. However, using such generic values is based on the fact that they are already familiar to professional communities. As a result, Bhatia (1993:13) considers such use as a “clever exploitation of the generic conventions by expert members of professional community”. It is a “clever exploitation” in the sense that hybrid or mixing genres are designed in a way to communicate ‘private intentions’ through the set of the communicative purposes intended to be achieved.

6.7.Limitation of study and suggestions for further research

Sure enough, every research no matter how well it is conducted and constructed has some limitations. Such limitations are due to the problems and difficulties that face the researcher during his research, either in the data collection stage or during the analysis of data. Therefore, this research comes with a number of limitations that are worth noting.

In fact, the research is limited in the sense that it only represents the study of thirty manuals. Due to access issues to such technical documents, data collection is restricted then to only the possible manuals that we can get without any difficulties that may lead to spend more time and effort. This was the obvious reason why our attention was directed towards household equipment since they have accessible manuals. On the other hand, manuals of machines that are designed for industrial purpose are not easy to get because permission of the company or factory's authority is needed for such kind of documents. In addition, most of the machines in industrial markets today are controlled via computer either integrated in the machine itself or linked to an external one. In this case, the manual for operation is electronically stored in the machine, generally as a help menu in case something goes wrong. Thus, under these circumstances collecting data relying on this kind of manuals is not possible. Additionally, the number of manuals to be collected in the corpus is influenced by the time constraints. Considering the size of the corpus, it will consume a considerable time and effort.

The results of this study reflect only the thirty manuals representing household equipments, and hence cannot be generalized to other types of manuals as the ones that represent industrial machines. As results, the identified moves in addition to types of sentences and vocabulary used to realize such moves do not necessary apply to manuals of industrial machines for instance. Assuming that they are designed for different purposes than that of household equipment they more likely have their structural moves and specific discourse community in which they generally occur.

Equally important, the results obtained from using the analysis tools are only to represent the current versions of the tools. To put it differently, since these tools are computer programs they are more likely to undergo many improvements during time at the level of accuracy and capacity. In that case, if we analyze them using newer versions

of such tools we may have differences in terms of results accuracy. Hence, they will be improved to give precise and adequate results. However, using such highly developed program requires purchasing the program license, which is not possible in our case. Still, there are many free analysis tools to choose from and they are continually improved to support researchers in their task.

By the same token, the researcher could not consider other aspects at the level of textual analysis as cohesive markers, tense or style used to write the instructions for both types of manuals. Thus, dealing with these aspects requires more time and specific tools that can process a large amount of data hence the corpora needs more than thirty manuals to tackle such aspects adequately.

In spite of the fact that these limitations may be seen as drawbacks, they can be explored as key points to inspire further researches. Therefore, with this intention, we recommend to extend the corpora to 100 manuals to be representative enough for this kind of genre and to enable a thorough textual analysis. In addition, the collection of data can be restricted to only include one or two dominant companies in the market. By doing so, we can know how they structure different types of manuals depending on nature of the audience. Thus, considering for instance only manuals produced by LG for both service and user manuals can reveal the differences that may occur in structure and style used to design such manuals moving from general (user manuals) to specific ones (service manuals).

As they represent genre of instructions, manuals as any technical documents are produced to satisfy the needs of the intended audience. Thus, this kind of technical documents can also be approached from a social perspective. With this view, such technical documents are treated as social constructs. In this regard, rather than dealing

with linguistic features that characterize such genre, research should focus on “the practices of groups the writer is writing to, writing for and writing from, as well as in the practices of groups” to which the writer belongs” (Dobrin 1994:44).

Knowing that, the scope of the research will be devoted to understand the activities of discourse community members to convey meaning through genre. That is, genre is analyzed in relation to the activities of community members including their conventions and shared knowledge. However, to investigate such aspects we need to consider the social context of the genre in question. This means that the analysis goes beyond texts to involve participants of that genre. Since participants are taken into consideration, analyzing genre in this way is generally based on ethnography method that entails the use of interviews and observations. In fact, such method is adopted by the New Rhetoric approach to genre, in which genre is seen as ‘social action’. It is more concerned with social aspects of genre and the actions a particular genre aims to accomplish.

In sum, investigating genre from different perspectives is the best strategy to have a much better understanding of the genre particularly in this era where genres develop quickly to meet the needs of the community. Such development helps the emergence of new genres and hence may affect the way we define and perceive them. This is the reason why we need to investigate every possible aspects of genre either on the textual or social levels.

Research Implications

Many studies have been conducted in the field of genre following different approaches and methods. Regardless of the approach they follow in their studies, researchers explore the structural features and conventions others use to communicate

via genres. The significance of such studies is that they provide a theoretical and, more importantly, pedagogical implications in teaching these genres. Therefore, they are rich resources from which students can learn linguistic features and rhetorical skills to communicate successfully. Analysing service and user manuals is one way of exploring genre of technical communication. Thus, by teaching genre's lexical and rhetorical features, we can help students become a part of the discourse community in which the genre occurs. With this intention, they can understand the activities and communicative purposes of community members. Hence, these members use genre to share information and thus, satisfy their communicative needs. This consideration helps students develop their genre's awareness.

Therefore, genre-based approach has many applications in teaching particularly in the field of ESP. One of such application is teaching writing in technical fields, as EST, for foreign language learners. As mentioned, students must be aware of the lexical and rhetorical features that structure the genre; in this case, it is genre of instructions. However, teaching them the structure of genre is half of the task. Students must be exposed to more examples of genre not only to be familiar with it but also to be able to develop their writing skills in this particular kind of genre. The results of this research, obtained from analysing service and user manuals, can be used in this direction hence, they show clearly the lexical and rhetorical structure of instructional discourse. In addition, the fact that we considered two types of manuals is very useful for students to teach them how to communicate to various audiences moving from general public to specific participants. In this study, these are represented by laymen and service technicians respectively. To do so, learners need to know how information is structured in technical documents such as manuals.

With reference to the research results, manuals as technical documents are structured using different moves that include a variety of lexico-grammatical features. So, in order to convey technical information as the one used in manuals, learners need to understand such moves and the purpose behind their use. This means that the moves, in fact, are used depending on the communicative purposes these documents want to convey. Learning to structure information through moves is not enough without considering the communicative purposes that necessitate their use in the writing process. In this context, genre approach is very beneficial for teaching writing hence students can learn the formal and functional properties of language and thus, learn why linguistic conventions are used for particular rhetorical effects (Bhatia 1993:6). In addition, it helps them to learn how to identify common genre patterns. In turn, these patterns, when acquired, will construct the students' background knowledge that can be used in other learning situations.

Given these points, teaching writing through genre approach can be explained through a "wheel model", as suggested by Hammond (1992). This model is simply a teaching-learning cycle that includes three phases as follows: modelling, joint negotiation of text by learners and teachers, independent construction of texts by learners.

Modelling: it refers to the discussion of genre focusing on texts structure and language.

Joint negotiation of text: In this phase, learners are assigned with exercises that involve relevant language forms. They are based on research, reading and extraction of information. Such exercises lead to a negotiation process between the teacher and students.

Independent construction of texts: it is the final phase where students are asked to produce texts depending on activities as research and writing.

Moreover, a genre approach helps students to become more flexible in their thinking and gives an understanding of how they can use writing as a tool to share information or to participate in social activities. Since there are many advantages of using genre in teaching, Hyland (2004:10-16) summarise the main ones as follows:

- ✓ ***Explicit:*** Makes clear what is to be learnt to facilitate the acquisition of writing skills.
- ✓ ***Systematic:*** Provides a coherent framework for focusing on both language and contexts.
- ✓ ***Needs-based:*** Ensures that course objectives and content are derived from students' needs.
- ✓ ***Supportive:*** Gives teachers a central role in scaffolding students' learning and creativity.
- ✓ ***Empowering:*** Provides access to the patterns and possibilities of variation in valued texts.
- ✓ ***Critical:*** Provides the resources for students to understand and challenge valued discourses.
- ✓ ***Consciousness-raising:*** Increases teachers' awareness of texts to confidently advise students on writing.

Thus, genre analysis is a key resource for teaching writing, particularly in the field of ESP, hence it describes communicative activities through the use of language and makes them explicit to the students. Such explicitness provides students with the appropriate knowledge to manipulate language according to their writing purposes.

Conclusion

From the above discussion, it becomes clear that the schematic structure of both types of manuals is based on a set of moves that are shared between them. However, there are moves that can only occur in a particular type of manuals. Such moves become a distinctive feature that determines the type of the manual as user or service manual. Thus, there are moves that are unique to each type of manuals, for instance ‘thanking the customer’ is only used in user manuals, while ‘servicing instructions’ is only used in service manuals. In spite of that, the shared moves of both types of manuals are used to serve different communicative purposes depending on the primary communicative purpose which is ‘to instruct’ for user manuals and ‘to repair’ for service manuals. Thus, while the purpose of ‘troubleshooting’ in user manuals is to fix minor problems, it is not the case for service manuals hence it is meant to help the technician to repair serious problems or defects.

General Conclusion

The overriding purpose of this study was to clarify the influence of the audience factor as well as the moves in attributing genre membership. Thus, considering communicative purposes expressed through moves helps to determine to what extent these factors contribute in changing the genre membership, which may result in the emergence of a new one. Taking that into account, assigning genre membership is more needed due to the developments in the science and technology fields as well as commerce. Accordingly, genre develops to keep up with such advances. However, this development at the level of genre leads to the emergence of new ones structured with new conventions addressing specific type of audience. Related to that aspect, many researches have been conducted based on different theories in the field of genre. Thus, the literature review described for this study is to reach a better understanding about the nature of genre including its definition. The main approaches described during the literature review, involving the functional and the systematic approach, are taken into consideration while dealing with the genre at hand.

To reveal the development of genre, the light is shed on genres that occur in the field of science and technology namely user and service manuals of household equipment. These two types of manuals as a particular kind of genre are developed according to audience needs. In addition, they represent a good example of genres that are produced to cope with technological advances. Since moves and communicative purposes are involved, it is more convenient to consider the first approach that is based on Swales work (1990) in which genre is classified according to communicative purposes. The second approach is to explain how the moves, used to convey communicative purposes, are realised through linguistic features. In fact, analysing

genre through lexico-grammatical features is the main concern of systemic functional linguistics, which is pioneered by the work of Halliday (1979).

The sample of the study consists of 30 user and service manuals, divided into two parts including fifteen manuals for each type. The manuals were chosen to represent household equipment. The choice of service manuals is based on that of user ones. That is, service manuals represent the same household equipment of those of user manuals. Following the corpus based approach, the data was analysed on the ground of moves and lexical sets referring to the two previously mentioned approaches. However, analysing lexical sets within such corpora requires the use of software. In this phase, the analysis supported by the software is a two-step process. First, the data needs to be refined through the use of 'text stripper', i.e. eliminate punctuations, numbers, figures and so on. Hence, they may interfere in the accuracy of the results. Second, the refined data was submitted to 'vocabulary profiler' which analysis lexical sets in terms of common words, academic words and technical word. The identified lexical sets give a clear image about the nature of the vocabulary used in each type of manuals.

The results gained from analysing both types of manuals in terms of moves and lexical sets are compared to draw out conclusions about the similarities and differences between such types of manuals. On the positive side, the two types of manuals share a number of moves. On the negative one, they differ in some of the moves that are unique to each type of manuals. However, the shared moves do not represent the same importance in both types of manuals. In user manuals, the shared moves are of crucial importance in the sense that they contribute directly in achieving the primary purpose of the user manuals. On the other hand, for service manuals, those moves are perceived as indirectly linked to their primary purpose. In fact, the moves that directly reflect their primary purpose are the unique ones.

In addition, the shared moves serve different communicative purposes according to the type of the manual in which they are used. Such difference becomes more significant when considering the primary purpose of the manuals. Knowing that user manuals are more concerned with instructing the user how to operate the product, it is clear that operating instructions in user manuals and in service ones are not meant to serve the same purpose. Operating instructions are not the primary concern of the service manuals but they support the technician in the product repairs because he needs to be familiar with operating instructions particularly for more sophisticated products. However, in user manuals such instructions are the heart of the manual because they intend to make the user operate the product at hand correctly.

According to the obtained results, the moves used in both types of manuals reveal that they represent different stages within the manuals. Thus, in user manuals the moves express four different stages. The first one refers to thanking the customer for buying the product. In this stage, the company conveys its selling intentions through a marketing strategy, which is thanking, that raises the customer's confidence about the company. The second stage is to prepare the user for operating the product by providing safety instructions, product features and installation instructions. The third stage instructs him about operating the product. The fourth stage includes maintenance and troubleshooting. The information provided in this stage is to maintain and expand the product life service. Therefore, these stages are set to achieve the manuals' intended purpose. However, even if the primary purpose of user manuals is achieved through the stage of operating instructions, the manuals involve a fourth stage, which is devoted to maintaining the product. In fact, this stage is beneficial to both the user and the company. Thus maintaining the product, on the one hand, gives the user a good

performance and a longer service. On the other hand, it saves the company repairs or replacement in case the product is still under the guarantee period.

Particularly, service manuals involve only three stages. The first stage reminds the technician of the importance of the instructions hence it asks him to read them before trying to service the product. The second stage, which mainly entails the shared moves with user manuals, is to prepare the technician for the repairs by making him more familiar with the product. Thus, this stage includes safety instructions, product features, installation, and operating instructions. The third stage consists of moves that directly reflect the purpose of repairs. It involves servicing instructions, schemas and diagrams, disassembly instructions and exploded view. With that being said, the service manuals do not go beyond their primary purpose once it is achieved as it is the case for user manuals, which include a fourth stage.

Following the systematic approach, the analysis revealed that there are different lexical sets used to convey the instructions represented by the identified moves. Since the two types of manuals are analysed based on the same lexical sets including common words, academic words, and technical words, more attention is given to the shared moves because they help showing the difference in the vocabulary used to express such moves. These lexical sets differ from one move to another in the sense that common words gradually decrease moving to more specific moves as troubleshooting. This assumption is true for both types of manuals. However, in service manuals common words are less used even in less specific moves as installation instructions. As a result, the use of such lexical sets depends on the type of the move as well as the type of the manuals. Thus, the gap between the types of manuals widens considerably in terms of common words when considering specific moves. In like manners, technical words show an increase in their rate of use in service manuals particularly in specific moves as

troubleshooting. Although user manuals are to address the layman, they also involve technical words used to describe the product at hand, for instance naming the different parts of the product.

Additionally, these moves show other differences in their linguistic realisations in both types of manuals. Such differences appear in the way they are expressed using larger grammatical units as sentences. Therefore, in terms of sentences the moves are conveyed through the following sentence types imperative, declarative, conditional, and interrogative. Depending on the move being expressed, some of these sentence types may not appear in the move. Thus, interrogative sentences are used mainly in troubleshooting but they do not appear in the other moves. Apart from the conditional, sentences which are not used in all of the moves, hence they are used only when necessary, imperatives and declaratives are to characterise most of the moves. This consideration makes them the most prominent sentence types. In user manuals, imperatives show a prominence of use in all of the shared moves except troubleshooting which is expressed mainly through the declaratives rather than imperatives. In service manuals the moves are realised through the imperatives with exception to operating instructions, which are conveyed through declaratives. With that being said, sentence types' distributions depend largely on the move and the types of the manuals. In other words, the moves that have direct relation to the manual purpose are expressed mainly using the imperative while other moves that are less related are expressed through the declaratives. To put it differently, in user manuals safety instructions, installation instructions, operating instructions are the main moves for this kind of manuals hence they serve directly their primary purpose. The reason why they are expressed using the imperatives. However, troubleshooting which is less related to their primary purpose is expressed through declaratives. In similar way, service manuals use imperatives to

convey troubleshooting that serve directly the purpose of the manuals. However, they do not use imperatives to express operating instructions, which characterize user manuals; since such move does not serve the primary purpose directly, they use declaratives instead.

Bibliography

- Aijmer, K. (1996). *Language in Contrast: Papers on Text-based Cross-linguistic Studies*. Lund University Press.
- Ariel, M. (2008). *Defining Pragmatics*. Cambridge university Press.
- Askehave, I. (1999). Communicative Purposes as Genre Determinant. *Hermes Journal of Linguistics No 23* , 13-23.
- Askehave, J. S. (2001). Genre identification and communicative purpose: A problem and a possible solution. *Applied Linguistics 22/2* , 195-212.
- Austin, J. (1962). *How to Do Things with Words*. Oxford University Press.
- Baker, M. (1993). *Corpus linguistics and translation studies: implications and applications*. John Benjamins.
- Baker, M. (1992). *In Other Words*. London: Routledge.
- Bhatia, V. (1997). Introduction: Genre Analysis and World Englishes. *World Englishes 16* , 313-19.
- Bhatia, V. K. (1993). *Analysing Genre: Language Use in Professional Settings*. London: Longman.
- Biber, D. (1993). Representativeness in Corpus Design. *Literary and Linguistic Computing* , 8 (4), 243-257.
- Biber, D. (2006). *University Language: A Corpus-based Study of Spoken and Written Registers*. John Benjamins.
- Biber, S. C. (2009). *Register, Genre, and Style*. Cambridge University Press.
- Borowick, J. N. (1996). *Technical Communication and Its Applications*. Prentice-Hall.
- Bowker, L., & Pearson, J. (2002). *Working with Specializd Langaue: A Practical Guide Using Corpora*. Routledge.
- Broughton, G. (1980). *Teaching English as a Foreign Language*. Routledge.
- Brown, G., & Yule. (1983). *Discourse Analysis*. Cambridge University Press.
- Budinski, K. (2001). *Engineers' Guide to Technical Writing*. ASM International.
- Byrne, J. (2006). *Technical Translation: Usability Strategies for Translating Technical* . Springer.
- Carrel, L. (1982). Cohesion is not Coherence. *TESOL Quarterly* , 16, 479-488.
- Carrel, L., Devine, & Eskey. (1998). *Interactive Approaches to Second Language Reading*. Cambridge University Press.

- Celce, M., & Olshtain, E. (2000). *Discourse and Context in Language Teaching*. Cambridge University Press.
- Coe, R. (2002). *The New Rhetoric of Genre: Writing political briefs*. NJ: Erlbaum.
- Cook, G. (1989). *Discourse*. Cambridge University Press.
- Coulthard, M. (1977). *An Introduction to Discourse Analysis*. Longman.
- Crystal, D. (1992). *Introducing Linguistics*. Penguin.
- Day, R., & Sakaduski, N. (2011). *Scientific English: A guide for Scientists and Other Professionals*. Greenwood.
- Devitt, A. J. (2004). *Writing Genres*. SIU Press.
- Devitt, M., & Hanley, R. (2003). Speech Acts and Pragmatics. In *Blackwell. Guide to the philosophy of language* , 147-167.
- Dobrin, D. (1983). What's technical about technical writing? *Baywood's technical communications* , 227-250.
- Dudley-Evan, T., & Maggie, J. (1998). *Developments in English for Specific purposes: A Multi-Disciplinary Approach*. Cambridge university Press.
- Eggins, S. (2004). *Introduction to Systemic Functional Linguistics*. A&C Black.
- Escoe, A. (2001). *The Practical Guide to People-Friendly Documentation*. ASQ Quality Press.
- Firth, J. R. (1951). Modes of meaning in Essays and studies. *The English Association Oxford university press* , 1935-95.
- Flood, W. (1957). *The Problem of Vocabulary in the Popularization of Science*. Birmingham Institute of Education.
- Flowerdew, J. (2002). *Academic Discourse*. Longman.
- Garcia, C. (2006). *Popper's Theory of Science*. A&C Black.
- Gitlow, H. (1989). *Tools and method for the improvement of quality*. USA: Richard d, IRWIN, INC.
- Gotti, M. (2008). *Invastigating Specialized Discourse*. Peter Lang.
- Granger, S. (1996). From CA to CIA and back: an integrated approach to computerised bilingual. *Cross-linguistic Studies* , 38-51.
- Grice, H. (1975). logic and Conversation In Cole. p and J.L. Morgen. *Syntax and semantics* , 41-58.
- Halliday, & Hassan. (1976). *Cohesion in English*. Longman.
- Halliday, M. A. (1978). *language as social Semiotic. The Social Interpretation of language and Meaning*. London: Edward Arnold.

- Halliday, M., Cermakova, A., Teubert, W., & Yallop, C. (2004). *lexicology and Corpus Linguistics*. A&C Black.
- Harris, Z. (1952). Discourse Analysis. *In Language* , 28, 1-30.
- Hatch, E. M. (1992). *Discourse and Language Education*. Cambridge University Press.
- Heino, H. (1992). Special Problems when Translating Specialized texts. *Fachsprache* , 3 (4), 111-120.
- Herman, D. (1995). *Universal Grammr and Narrative Form*. Duke university Press.
- Herman, P., & Gruyter, W. (1976). *History of Linguistic Thought and Contemporary Linguistics*. Walter & Co.
- Hirsh, D. (2010). *Academic Vocabulary in Context*. Peter Lang.
- Houghton, D. (1995). *Creating Computer Software User Guides: From Manuals to Manuals to Menus*. London: McGraw-Hill.
- Hugoe, M. (2001). *A Short History of Strcutural Linguistics*. Cambridge University Press.
- Hutchinson, T., & Waters, A. (1987). *English for specific Purposes:A Learning Centred Approach*. Cambridge University Press.
- Hylland, K. (2002). Directives Argument and Engagement in Academic Writing. *Applied Linguistics* , 23 (2), 215-239.
- Hylland, K. (2000). *English for Academic Purposes: An Advanced Resourse Book*. Routledge.
- Johansson, & Hofland. (1994). *Towards an English–Norwegian parallel orpus*. Rodopi.
- John, A. (1997). *Text and Role and Context: Developing Academic Literacies*. Cambridge University Press.
- Katz, J., & Fodor, A. (1963). The Structure of Semantic Theory. *Language* , 39 (2), 170-210.
- Keith, A. (2012). *Pragmatics*. Cambridge University Press.
- Killingsworth, J., & Gilbertson, M. (1992). *Signs, Genres, and Communities in technical Communication*. Baywood.
- Lassen, I. (2003). *Accessibility and Acceptibility in Technical Manuals: A Survey of Style and Grammatical Metaphor*. J.benjamins Pub.
- Lassen, I. (1998). Technical Manuals in a Bhatian Genre Perspective. *Netværk LSP, SSP* , 104-125.
- Lataiwish, A. Y. (1999). *Principles of Translation*. Dar Annahda Alarabiya.
- Leech, G. (1992). Corpora and Theories of Linguistic Performance. *Corpus Linguistics* , 105-122.

- Leech, G. (2007). New resources, or just better old ones? *Corpus Linguistics and the Web* , 134-49.
- Levinson, S. (2000). *Presumptive meanings: The Theory of Generalized Conversational Implicature*. MIT Press.
- Longacre, R. E. (1996). *The Grammar of Discourse* . Springer.
- Lyons, J. (1995). *Linguistic Semantics: An Introduction*. Cambridge University Press.
- Lyons, J. (1977). *Semantics*. London: Cambridge University Press.
- Malinowski, B. (1935). *Coral Gardens and their Magic*. Allen and Unwin.
- Mancuso, J. C. (1990). *Mastering Technical Writing*. Menlo Park: Wesley Publishing Company.
- Martin, J. (1984). Language Register and Genre. *Children Writing: Reader* , 21-30.
- Martin, J. R. (1997). *Genre and institutions: Social Processes in The Workplace and School*. Cassell.
- Martin, J. R. (1985). Process and Text: Two Aspects of Semiosis in J. Benson and W. Greaves: Systemic Perspectives on Discourse. *Theoretical Papers vol 1* , 248-74.
- McEnery, T., & Hardie, A. (2012). *Corpus linguistics Method Theory and Practice*. Cambridge University Press.
- McEnery, T., & Wilson. (2001). *Corpus Linguistics*. Edinburgh University Press.
- McEnery, T., Xiao, R., & Tono, Y. (2006). *Corpus-based Language Studies: An Advanced Resource Book*. Taylor and Francis.
- Mey, J. (1993). *Pragmatics: An Introduction*. Blackwell.
- Miller, C. (1984). Genre as Social Actions. *Quarterly Journal of Speech* , 70, 23-42.
- Mollin, S. (2007). The Hansard Hazard: Gauging the Accuracy of British Parliamentary. *Corpora* , 2 (2), 187-210.
- Munby, J. (1978). *Communicative Syllabus Design*. Cambridge University Press.
- Nesselhauf, N. (2005). *Collocations in a Learner Corpus*. Benjamins.
- Nunan, D. (1993). *Introducing Discourse Analysis*. Penguin.
- Olohan, M. (2015). *Scientific and Technical Translation*. Routledge.
- Palmer, F. R. (1981). *Semantics*. Cambridge University Press.
- Paltridge, B. (2006). *Discourse Analysis: An Introduction*. Bloomsbury Academic.
- Paltridge, B. (1997). *Genre, Frames and Writing in Research Setting*. Benjamins.
- Price, J. (1984). *How to Write Computer Manual: A handbook of software Documentation*. Menlo Park: Benjamin Publishing Company.

- Ramey. (1989). Escher Effects in Online Text. *The Society of Text: Hypertext and Social Construction of Information. The MIT Press* , 388-402.
- report, s. a. (1995).
- Robinson, & Paulie. (1980). *English for Specific Purposes: The Present Position*. Pergamon Press.
- Robinson, P. (1991). *ESP Today: A Practitioner's Guide*. Prentice Hall.
- Rubens, P. (2002). *Science and Technical Writing: A Manual of Style*. Routledge.
- Saeed, J. (2011). *Semantics*. John Wiley & Sons.
- Schriver, K. (1997). *Dynamics in Document Design: Creating Texts for Readers*. John Wiley & Sons.
- Searle, J. R. (1975). *Indirect Speech Acts*. Academic Press.
- Smith, N., & Ivanic, M. a. (1998). Issues in transcribing a corpus of children's. *Literary and Linguistic Computing* , 312-29.
- Stevens, P. (1988). ESP after twenty years: A re-appraisal. *ESP State of the ART* , 1-13.
- Stevens, P. (1971). *The language of Instruction and the Formation of Scientific Concepts*. Praeger.
- Svartvik, J., & Quirk. (1980). *A Corpus of English Conversation*. Gleeurp.
- Swales, J. (1988). Discourse Communities, Genres and English as an International Language. *World Englishes* , 7 (2), 211-20.
- Swales, J. (1985). *Episodes in ESP*. Prentice Hall.
- Swales, J. (1990). *Genre Analysis: English in academic Research Settings*. Cambridge University Press.
- Swales, J. (1992). Language for Specific Purposes. . *International Encyclopedia of Linguistics vol:2 Oxford university Press* , 300.
- Swales, J. (1998). *Other Floors, Other Voices: A Textography of a Small University building*. Mahwah, NJ: Lawrence Erlbaum.
- Swales, J. (1971). *Writing Scientific English*. Nelson.
- Tognini-Bonelli, E. (2001). *Corpus Linguistics at Work*. John Benjamins.
- Trimble, L. (1985). *EST A Discourse Approach*. Cambridge University Press.
- Valli, C., & Lucas, C. (2000). *Linguistics of American Sign Language*. Gallaudet University Press.
- Vander, V., Sonia, Z., & Barnbrook, G. (2011). *Perspectives on Corpus Linguistics*. Benjamins.

- Varadi, T. (2001). The linguistic relevance of Corpus Linguistics. *UCREL Technical Papers* , 13, 587-593.
- Verginia, L. (2003). *An Introduction to Pragmatics*. University of Michigan Press.
- Wang, S.-P. (2005). Corpus-based Approaches and Discourse Analysis to Reduplication and repetition. *Journal of Pragmatics* , 37 (4), 505-540.
- Weiss, E. H. (1985). *How to Write a Usable manual*. Philadelphia: USA:ISI.
- White, F. D. (1996). *Communicating technology: Dynamic Processes and Models for Writers*. New York: Harper Collins College Publishers.
- Widdowson, H. (1979). *Explorations in Applied Linguistics*. Oxford University Press.
- Widdowson, H. G. (1998). *The Conditions of Contextual Meaning. Context in Language Learning and Language Understanding*. Cambridge: Cambridge University Press.
- Widdowson, H. (1978). *Teaching Language as Communication*. Oxford University Press.
- Widdowson, H. (2004). *Text, Context, and Pretext; Critical issues in Discourse Analysis* . Wiley-Blackwell.
- Yee, C. (1975). Sequence Signals in Technical English. *RELC Journal* , 6 (2), 63-101.
- Yule, G. (1996). *Pragmatics*. Oxford University Press.
- Yule, G. (2005). *The Study of Language: An Introduction*. Cambridge University.

Appendices

Due to space constraints the appendices, which contain the analysed user and service manuals, are not included in the thesis but rather provided in a CD. The appendices included in the thesis provide only the first page of the thirty analysed manuals.

APPENDIX I: User Manuals

Appendix 1

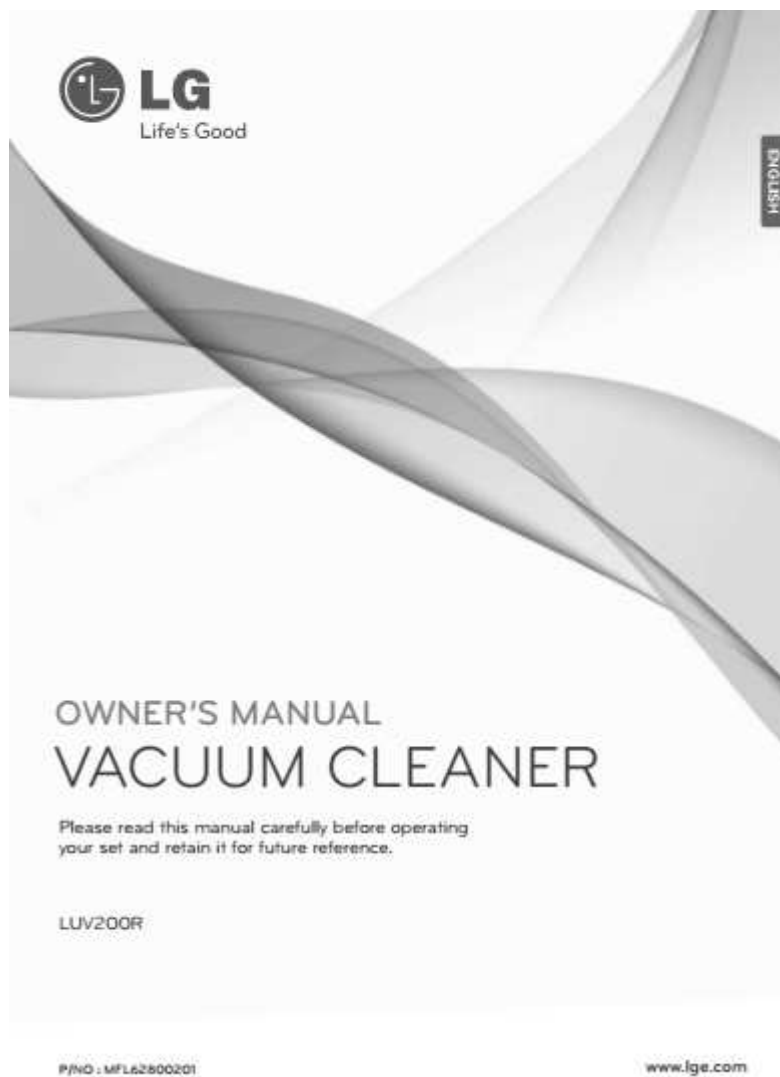

Appendix 2

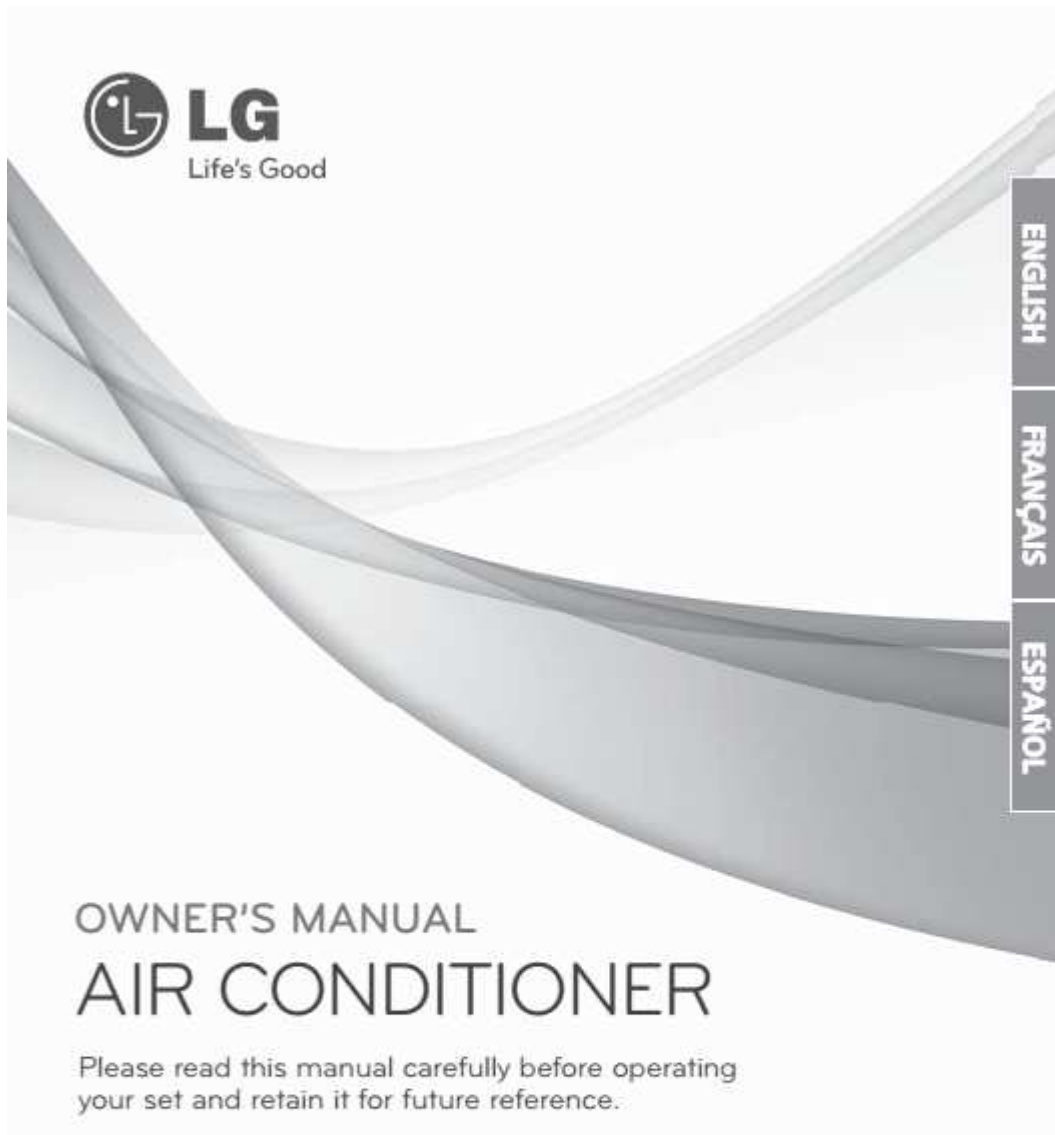

OWNER'S MANUAL AIR CONDITIONER

Please read this manual carefully before operating your set and retain it for future reference.

TYPE : WALL MOUNTED

P/NO : MFL63288101

www.lge.com

BEKO

installation & operating **Vented**
instructions and drying guidance **Sensor Dryer**

DRVS 73 W
DRVS 73 S



get the **best** from your new tumble dryer

INSTALLATION GUIDE

BROAN[®]

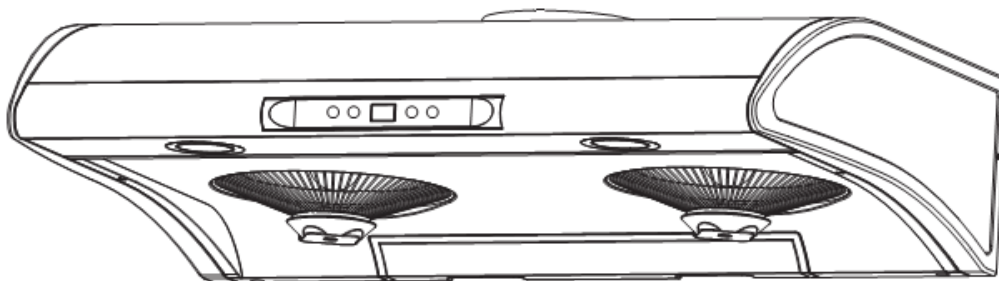

HB0111

BDF SERIES

⚠ INTENDED FOR DOMESTIC COOKING ONLY ⚠

READ AND SAVE THESE INSTRUCTIONS

INSTALLER: LEAVE THIS GUIDE WITH THE HOMEOWNER.
HOMEOWNER: OPERATION AND CARE INFORMATION ON PAGES 9-10.

Broan-NuTone Canada Inc.; Mississauga, Ontario 1-877-896-1119

www.broan.ca

REGISTER YOUR PRODUCT ON LINE AT: www.broan.com/register

Appendix 5

Register your product and get support at
www.philips.com/welcome

Hairdryer

HP8102



EN User manual

PHILIPS

Appendix 6

BRAUN

SI 6595 SI 6260
SI 6590 SI 6250
SI 6560 SI 6120
SI 6550

FreeStyle



www.braun.com

Type 4 581
Type 4 576
Type 4 575
Type 4 574

4-675-378/00/00-20
Korea/CE



LCD TV OWNER'S MANUAL

LCD TV MODELS

37LB5D / 42LB5D / 47LB5D

52LB5D

32LB4D / 37LB4D / 42LB4D

Please read this manual carefully before operating your set.
Retain it for future reference.

Record model number and serial number of the set.
See the label attached on the back cover and quote this
information to your dealer when you require service.

ENERGY STAR is a set of power-saving
guidelines issued by the U.S.
Environmental Protection Agency(EPA).



As an ENERGY STAR
Partner LGE U.S.A.,
Inc. has determined
that this product
meets the ENERGY
STAR guidelines for
energy efficiency.



REFRIGERATOR
RB1844SW / RB1844SL
RB2044SW / RB2044SL



OWNER'S MANUAL



In the U.S. for questions about features,
operation/performance, parts, accessories or service, call:
1-800-726-7864 (1-800-SAMSUNG)
www.samsungusa.com

⚠ Warning: This water heater is not suitable for use in manufactured (mobile) homes!

Use & Care Manual With Installation Instructions for the Installer



Residential Gas Water Heaters

Residential 30, 40, 50, and 60 Gallon

The purpose of this manual is twofold: one, to provide the installer with the basic directions and recommendations for the proper installation and adjustment of the water heater; and two, for the owner-operator, to explain the features, operation, safety precautions, maintenance and troubleshooting of the water heater. This manual also includes a parts list.

It is imperative that all persons who are expected to install, operate or adjust this water heater read the instructions carefully so they may understand how to perform these operations. If you do not understand these instructions or any terms within it, seek professional advice.

Any questions regarding the operation, maintenance, service or warranty of this water heater should be directed to the seller from whom it was purchased. If additional information is required, refer to the section on "If you need service."

Do not destroy this manual. Please read carefully and keep in a safe place for future reference.

⚠ Recognize this symbol as an indication of Important Safety Information!

⚠ WARNING: If the information in these instructions is not followed exactly, a fire or explosion may result causing property damage, personal injury or death.

⚠ FOR YOUR SAFETY!

— Do not store or use gasoline or other flammable vapours or liquids or other combustible materials in the vicinity of this or any other appliance. To do so may result in an explosion or fire.

— WHAT TO DO IF YOU SMELL GAS

- Do not try to light any appliance.
- Do not touch any electrical switch; do not use any phone in your building.
- Immediately call your gas supplier from a neighbour's phone. Follow the gas supplier's instructions.

- If you cannot reach your gas supplier, call the fire department.
 - Do not return to your home until authorized by the gas supplier or fire department.
- Improper installation, adjustment, alteration, service or maintenance can cause property damage, personal injury, or death. Refer to this manual. Installation and service must be performed by a qualified installer, service agency or the gas supplier.



WF7704NA(W/V/S/C/R) WF7600NA(W/V/S/C/R)
WF7702NA(W/V/S/C/R) WF7608NA(W/V/S/C/R)
WF7700NA(W/V/S/C/R) WF7522NA(W/V/S/C/R)
WF7708NA(W/V/S/C/R) WF7520NA(W/V/S/C/R)
WF7604NA(W/V/S/C/R) WF7528NA(W/V/S/C/R)
WF7602NA(W/V/S/C/R)

Washing Machine user manual

imagine the possibilities

Thank you for purchasing a Samsung product.
To receive a more complete service,
please register your product at
www.samsung.com/global/register



SONY

4-416-299-11(1)

Digital HD Video Camera Recorder

Operating Guide

Please also refer to :

<http://www.sony.net/SonyInfo/Support/>

Table of contents	
Getting started	
Recording/Playback	
Advanced operations	
Editing	
Saving movies and photos with a computer	
Saving images with an external device	
Customizing your camcorder	
Others/Index	

HANDYCAM

AVCHD **HDMI**
Progressive

HEURTEL

MINORSTICK

**SD
XC**
CLASS 6

**NAVTEQ
MAPS**



<http://us.lgservice.com>

MICROWAVE OVEN

OWNER'S MANUAL

PLEASE READ THIS OWNER'S MANUAL
THOROUGHLY BEFORE OPERATING.

LMV1813SB
LMV1813SW
LMV1813ST

P/NO.: MFL56516411
Printed in China



DISHWASHER

USER'S GUIDE

Please retain this owner's manual for future reference.
Read and follow all safety rules and instructions before using this product.

LAVAPLATOS

GUIA DE USUARIO

Guarde este manual de usuario para referencia futura. Lea y siga todas las reglas e instrucciones de seguridad antes de utilizar este producto.

LAVE-VAISSELLE

GUIDE DE L'UTILISATEUR

Veuillez conserver ce manuel de l'utilisateur pour référence future. Lisez et suivez toutes les règles et les instructions relatives à la sécurité avant d'utiliser ce produit.

Model/Modelo/Modèle

LDF7932WW
LDF7932BB
LDF7932ST

To contact LG Electronics:
1-800-243-0000 (US)
Or visit us on the Web at: us.lge.com

Para comunicarse con LG Electronics:
1-800-243-0000 (US)
O visítenos en la Web en: us.lge.com

To contact LG Electronics:
1-888-542-2623 (Canada)
Or visit us on the Web at: ca.lge.com

Pour contacter LG Electronics, appelez le
1-888-542-2623 (Canada)
Ou visitez-nous sur le Web à l'adresse :
ca.lge.com



brother®

• **1** KNOWING YOUR SEWING MACHINE

• **2** SEWING BASICS

• **3** UTILITY STITCHES

• **4** APPENDIX

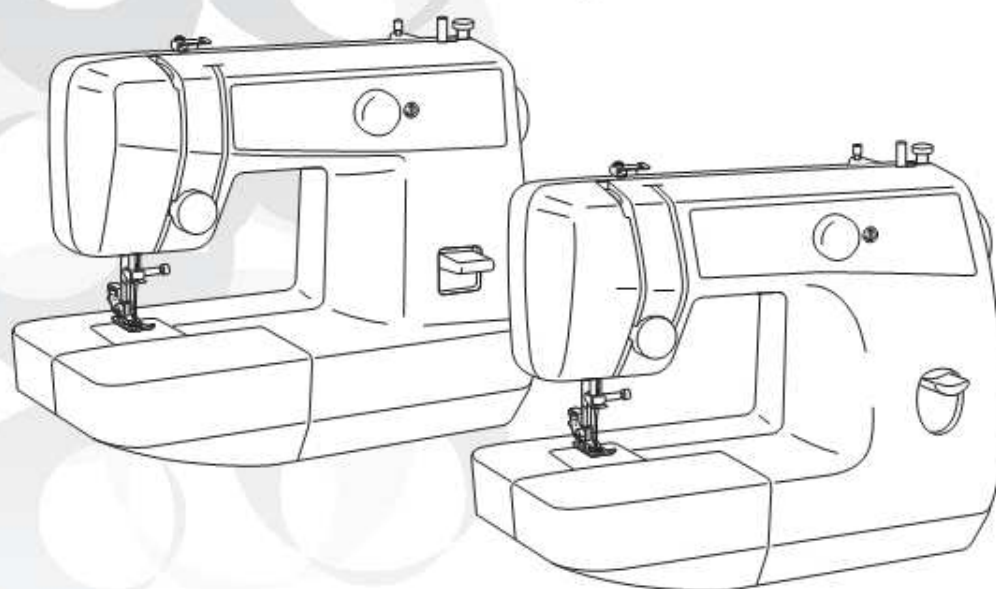

Basic Sewing and Mending Machine
Operation Manual



ELECTRIC OIL FILLED RADIATORS
INSTRUCTIONS FOR USE
SAVE THESE INSTRUCTIONS

**LOS RADIADORES ELÉCTRICOS DE
ACEITE**

INSTRUCCIONES PARA EL USO
REPASE Y GUARDE ESTAS INSTRUCCIONES
LEA CUIDADOSAMENTE ESTE INSTRUCTIVO
ANTES DE USAR SU APARATO

LES RADIATEURS À BAIN D'HUILE
MODE D'EMPLOI
CONSERVEZ CE MODE D'EMPLOI

RADIATORI AD OLIO
ISTRUZIONI PER L'USO
CONSERVARE LE PRESENTI ISTRUZIONI

TYPE/MODELE/MODELO/MODELLO:
TRV0715-TRV0715T

Register this product on-line and receive a free trial issue of Cook's Illustrated. Visit www.delonghiregistration.com. Visit www.delonghi.com for a list of service centers near you. (U.S. Only)

Registre este producto en línea y reciba un ejemplar gratis de Cook's Illustrated. Visite www.delonghiregistration.com. Visite www.delonghi.com para ver la lista de centros de servicios cercanos a usted. (Solamente en los Estados Unidos)

Enregistrez ce produit en ligne et recevez un numéro gratuit de Cook's Illustrated. Visitez www.delonghiregistration.com. Visitez www.delonghi.com pour y voir une liste des centres de réparation proches de chez vous. (É.-U. uniquement)

Registra questo prodotto "on-line" per ricevere una copia omaggio della rivista Cook's Illustrated. Visita www.delonghiregistration.com. Visita www.delonghi.com per una lista dei centri di servizio a te più vicini. (Solo negli Stati Uniti).

ELECTRIC CHARACTERISTICS/CARACTÉRISTIQUES ÉLECTRONIQUES
CARACTERISTICAS ELECTRICAS/CARATTERISTICHE ELETTRICHE
120V 1500W

APPENDIX II: Service Manuals

Appendix 1



DISHWASHER SERVICE MANUAL

NOTE

BEFORE SERVICING THE UNIT, PLEASE READ THIS MANUAL CAREFULLY FOR SAFETY AND CORRECT SERVICES.

MODEL : LD-1403W1

Appendix 2



website: <http://biz.LGservice.com>
e-mail: <http://www.LGservice.com/techsup.html>

LCD TV SERVICE MANUAL

CHASSIS : LP62C
FACTORY MODEL : 37LC2R-TH / 42LC2R-TH

MODEL : 37LC2R / 42LC2R

CAUTION
BEFORE SERVICING THE CHASSIS,
READ THE SAFETY PRECAUTIONS IN THIS MANUAL.

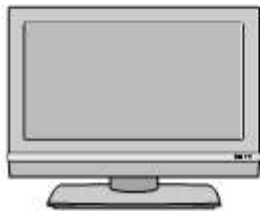

Appendix 3

GoldStar

website <http://www.lgservice.com>
e-mail <http://www.lgservice.com/techsup.html>

MICROWAVE OVEN SERVICE MANUAL

**MODEL: MV1526W
MV1526B**

CAUTION
BEFORE SERVICING THE UNIT, READ THE
SAFETY PRECAUTIONS IN THIS MANUAL.



ROOM AIR CONDITIONER

INDOOR UNIT

SH12VCD

SH09VCD

OUTDOOR UNIT

SH12VCDX

SH09VCDX

SERVICE *Manual*

AIR CONDITIONER

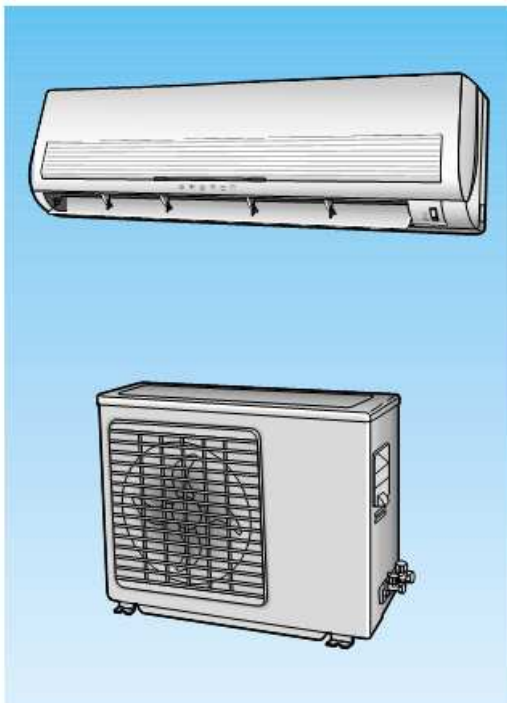

CONTENTS

1. Precautions
2. Product Specifications
3. Operating Instructions and Installation
4. Disassembly and Reassembly
5. Troubleshooting
6. Exploded Views and Parts List
7. PCB Diagrams
8. Wiring Diagrams



SERVICE **GUIDE**

SIDE-BY-SIDE REFRIGERATOR



**Model:
RS2555SL**

SAM0061

Appendix 6



WASHING MACHINE SERVICE MANUAL

CAUTION
BEFORE OFFERING SERVICE, READ THIS MANUAL
CAREFULLY TO DIAGNOSE
TROUBLES CORRECTLY.

**MODEL : WF-T851 / T852 / T853 / T802 / T902
WF-T652(T652A) / T452(T452A) / 402**



SERVICE MANUAL

INDUCTION COOKERS WITH RTCS TECHNOLOGY (REAL TIME TEMPERATURE CONTROL SYSTEM) COUNTER TOP/BUILT IN/WOK MODELS



IMPORTANT NOTE:

INDUCTION COOKERS MANUFACTURED WITH RTCS TECHNOLOGY WILL HAVE
FIVE DIGITS IN THE CENTER OF THE SERIAL NUMBER: EXAMPLE: BA06.00001.0505

MODELS

GIU 1.5 (BH/BA 1500)

GIU 1.8 (BH/BA 1800)

GIU 2.5 (BH/BA 2500)

GIU 3.5 (SH/BA 3500)

GIU 5.0 (SH/BA 5000)

GIU 2.5 BI (BH/IN 2500)

GIU 3.5 BI (SH/IN 3500)

GIU 5.0 BI (SH/IN 5000)

GIWOK 3.5 (SH/WO 3500)

GIWOK 5.0 (SH/WO 5000)

GIWOK 3.5 BI (SH/WO/IN 3500)

GIWOK 5.0 BI (SH/WO/IN 5000)

Appendix 8



Service Manual

MODEL: DV-700S



The Bradford White
DEFENDER
Safety System™

Flammable Vapor Ignition Resistant Water Heater



SERVICE MANUAL

**Troubleshooting Guide
and Instruction for Service**

(To be performed ONLY by qualified service providers)

**For the Bradford White
Defender Safety System™
Models:**

MI30T*F(BN,CX)2
MI30S*F(BN,CX)2
MI303T*F(BN,CX)2
MI40T*F(BN,CX)2
MI403S*F(BN,CX)2
MI404T*F(BN,CX)2
MI503*F(BN,CX)2
MI50L*F(BN,CX)2
MI504S*F(BN,CX)2

M430T*F(BN,CX)2
M4403S*F(BN,CX)2
M4403T*F(BN,CX)2
M450S*F(BN,CX)
M1XR403S*F(BN,CX)2
M1XR504T*F(BN,CX)2
M2XR504T*F(BN,CX)2
M2C504T*F(BN,CX)
50T65F(BN,CX)

(*) Denotes Warranty Years.

Manual 44943A

Save this manual for future reference

BRADFORD WHITE
CORPORATION



CONDENSING DRYER SERVICE MANUAL

CAUTION

READ THIS MANUAL CAREFULLY TO DIAGNOSE TROUBLE
CORRECTLY BEFORE OFFERING SERVICE.

MODEL : TD-C7004** Series

LK3-B430E

SERVICE MANUAL

Please read this manual before making any adjustments.

ELECTRONIC LOCKSTITCH BAR TACKER

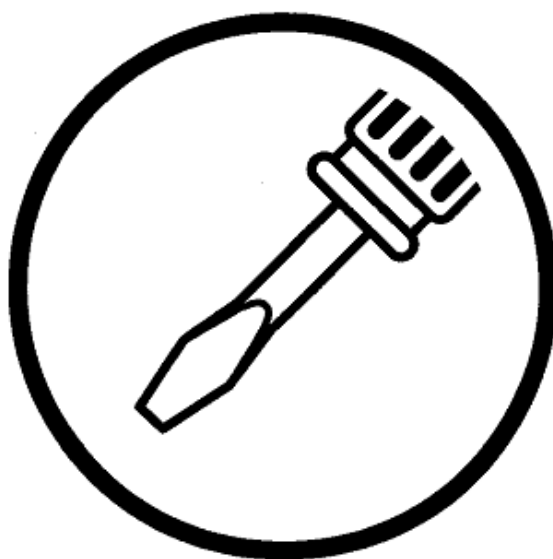

brother.

Boiler steam iron Provapor

GC 6022

Service
Service
Service



Philips Domestic Appliances and Personal Care

Service Manual

PRODUCT INFORMATION

Features

Iron, Azur

- Careeza soleplate
- Max. steam output 60 g/min
- Cord length 1.9 m

Boiler

- Inox boiler
- Capacity 1 litre

TECHNICAL INFORMATION

Voltage : 220 - 240 V
Frequency : 50 - 60 Hz

Power consumption : Iron : 800 W
Boiler : 1200 W
Pressure : 2.5 bar

Water advice : Suitable for tap water use. However if the tap water in your area is very hard, we advise you to mix it with a equal portion of distilled water or to use distilled water only.

Soleplate

Careeza is a multi layer chemical substance that gives an excellent gliding over various fabrics and better care for the garments.

This product meets the requirement regarding interference suppression on radio and television.



GSM TELEPHONE SGH-i900

SERVICE *Manual*

GSM TELEPHONE

CONTENTS



1. Safety Precautions
2. Specification
3. Product Function
4. Array course control
5. Exploded View and Parts list
6. MAIN Electrical Parts List
7. Disassembly and Assembly Instructions
8. Block Diagrams
9. PCB Diagrams
10. Chart of Troubleshooting
11. Reference data

Appendix 14

SERVICE MANUAL

Ver 1.0 2005.12
Revision History

How to use
Acrobat Reader

Internal memory
ON BOARD



LEVEL 2

US Model
Canadian Model
AEP Model
UK Model
E Model
Australian Model
Chinese Model
Brazilian Model
Hong Kong Model
Korea Model

Link

SPECIFICATIONS	BLOCK DIAGRAMS	PRINTED WIRING BOARDS
SERVICE NOTE	FRAME SCHEMATIC DIAGRAMS	REPAIR PARTS LIST
DISASSEMBLY	SCHEMATIC DIAGRAMS	

• Precaution on Replacing the SY-14S board

Note 1: The components identified by mark A, as marked (A) with mark A, are critical for safety. Replace only with part number specified.	Note 2: Les composants identifiés par une marque A, sont critiques pour la sécurité. Ne les remplacer que par une pièce portant le numéro spécifié.
---	---

www.DePreysWildlife.com

DIGITAL STILL CAMERA
SONY



Internal Use Only

Website <http://biz.lgservice.com>

VACUUM CLEANER **SERVICE MANUAL**

MODEL : VK8710H, VKC902HT
VC9072R, V-KC9700HT
V-KC20910HT

CAUTION

BEFORE SERVICING THE UNIT, READ THE
"SAFETY PRECAUTIONS" IN THIS MANUAL.



P/NO : MFL37414502

July, 2007
Printed in Korea

Résumé

Le but de ce travail de recherche est d'étudier l'influence de la communauté du discours sur les objectifs de communication d'un genre. L'objectif est donc d'analyser et déterminer comment un changement dans les objectifs de communication, s'il y en a, affecte la classification du genre. Pour atteindre ces objectifs, la recherche se concentre sur le genre des instructions qui dispose d'un large éventail de public représentant la communauté du discours, allant du général au très spécifique. Ainsi, cette recherche explore le genre des instructions du domaine technique par l'analyse des manuels d'utilisateur et de maintenance. Elle tente de décrire la structure d'un tel genre ainsi que d'expliquer comment l'information technique, représenté par des instructions, est transmise à différents types de public notamment les personnes ordinaires et les techniciens. La méthodologie utilisée pour l'enquête est basée sur l'approche par corpus. L'échantillon de l'étude se compose de trente manuels d'utilisation et de maintenance représentant les différents produits utilisés dans le marché Algérien. Compte tenu de la taille des données, l'étude a été réalisée en différentes étapes. Tout d'abord, le chercheur identifie, manuellement, les mouvements utilisés pour structurer le genre. Deuxièmement, les données sont traitées en utilisant différents outils d'analyse de texte pour déterminer les caractéristiques linguistiques y compris le type de phrase et les ensembles lexicaux utilisés pour construire les mouvements identifiés. Les résultats à obtenir à partir des deux types de manuels sont comparés pour connaître les changements qui en résultent par rapport à la communauté du discours général au communauté spécifique. En fait, la comparaison des résultats a révélé que la modification de la communauté de discours peut affecter l'objectif de communication d'un tel genre. Cependant, elle ne conduit pas à un ensemble d'objectifs de communication complètement différents parce que certains objectifs de communication sont communs entre les deux types de manuels. Cette similitude est due au fait que les deux types de manuels partagent, dans une certaine mesure, le même schéma de mouvements qui reflète les objectifs de communication destinés. En outre, les différences entre les deux types de manuels montrent clairement que le changement qui peut se produire au niveau de l'objectif de communication n'affecte pas nécessairement la classe de genre et ne nous donne donc pas un type de genre différent.

ملخص

يهدف هذا البحث إلى دراسة تأثير المجتمع الخطاب على أهداف التواصل للأنماط الأدبية. كما يسعى إلى الكشف عن مدى تأثير التغيرات في أهداف التواصل، إذا كان هناك أي تغيير، على نوع الأنماط الأدبية ولتحقيق هذه الأهداف، يلقي البحث الضوء على نوع من التعليمات التي لديها مجموعة واسعة من الجمهور الذي يمثل "مجتمع الخطاب"، سواء كان عاما أو خاصا. وهكذا، فإن البحث يسعى إلى استكشاف هذا النوع من التعليمات في كتيبات المستخدم أو الصيانة من خلال تقديم وصف شامل حول تركيبة هذا النوع من الأنماط الأدبية و كيفية نقل المعلومات التقنية من خلال التعليمات إلى أنواع مختلفة من الجمهور و المتمثل في الأشخاص العاديين و التقنيين في مجال الصيانة. وتستند المنهجية المستخدمة في البحث على تحليل النصوص المكتوبة. تتكون عينة الدراسة من ثلاثين كتيبا للمستخدم و الصيانة حيث تمثل هذه الكتيبات مختلف المنتجات المستخدمة في السوق الجزائرية. وبالنظر إلى حجم البيانات و تنوعها فان عملية التحليل تحتاج إلى عدة خطوات. أولا، يحدد الباحث، يدويا، "الانتقالات" التي تستخدم لتنظيم هذا النوع من الأنماط الأدبية. ثانيا، يتم معالجة البيانات عن طريق الحاسوب وذلك باستخدام مختلف أدوات تحليل النصوص لتحديد الخصائص اللغوية بما في ذلك نوع الجمل و المفردات المستخدمة لبناء "الانتقالات" التي تم تحديدها في الخطوة السابقة. أخيرا، يقوم الباحث بمقارنة النتائج المتحصل عليها من كلا النوعين من الكتيبات ، وذلك لمعرفة مختلف التغيرات الناتجة من خلال الانتقال من مجتمع الخطاب العام إلى مجتمع خطاب خاص. في الواقع، كشفت الدراسة من خلال المقارنة بين النتائج لكلا النوعين من الكتيبات ان تغير مجتمع الخطاب لديه تأثير على الأهداف التواصلية لهذا النوع من الأنماط الأدبية. ومع ذلك، فإنه لا يؤدي إلى مجموعة مختلفة تماما من الأهداف التواصلية. فالدراسة تثبت بأنه يوجد بعض الأهداف التواصلية المشتركة بين هذين النوعين من كتيبات المستخدم و الصيانة. ويرجع ذلك إلى حقيقة أنها تشترك إلى حد ما، في نفس نمط "الانتقالات" التي تعكس الأهداف التواصلية المقصودة. وبالإضافة إلى ذلك، فإن الاختلافات بين هذين النوعين من كتيبات المستخدم و الصيانة توضح أن التغيير الذي قد يحدث على مستوى الأهداف التواصلية لا يؤثر بالضرورة على نوع النمط الأدبي، وبالتالي فان هذا التغيير لا يؤدي بالضرورة إلى ظهور نوعا مختلفا من الأنماط الأدبية.