

## Maximum tangential stress prediction of mixed-mode crack propagation in FGMs

Abdelkader BOULENOUAR<sup>1\*</sup>, Nabil BENAMARA<sup>1</sup> and Noureddine BENSEDDIQ<sup>2</sup>

<sup>1</sup> Materials and Reactive Systems Laboratory, Mechanical Engineering Department, University of Sidi-Bel-Abbes, BP. 89, City Larbi Ben Mhidi, Sidi Bel Abbes 22000, Algeria.

<sup>2</sup> Mechanics Laboratory of Lille, CNRS UMR 8107, Ecole Polytech'Lille, University of Lille1, 59655 Villeneuve d'Ascq, France

\*Corresponding author: E-mail: [ae\\_k\\_boulenouar@yahoo.fr](mailto:ae_k_boulenouar@yahoo.fr)

**Abstract** - The objective of this work is to present a numerical modeling of crack propagation path in functionally graded materials (FGMs) under mixed-mode loadings. The Maximum tangential stress approach (MTS) and the displacement extrapolation technique (DET) are investigated in the context of fracture and crack growth in FGMs. Using the Ansys Parametric Design Language (APDL), the direction angle is evaluated as a function of stress intensity factors (SIFs) at each increment of propagation and the variation continues of the material properties are incorporated by specifying the material parameters at the centroid of each finite element. In this paper, several applications are investigated to check for the robustness of the numerical techniques. The defaults effect (inclusions and cavities) on the crack propagation path in FGMs are highlighted.

**Keywords:** Functionally graded materials; Mixed-mode; Displacement extrapolation; Stress intensity factor.

### Nomenclature

$K_I, K_{II}$  SIFs corresponding to mode I and mode II, respectively

$E_{tip}$  Young's modulus given at crack-tip

$\nu_{tip}$  Poisson's ratio given at crack-tip

$L$  Length of the singular element side

$\theta_0$  crack initiation angle

### 1. Introduction

Functionally Graded Materials (FGMs) are inhomogeneous materials which are widely used in technological application. In recent years, these materials have been especially studied its mechanical behaviors using different approaches. For the fracture of the FGMs, many studies have considered various crack problems in non-homogeneous materials. Using FEM analysis, Kim and Paulino [1] evaluated the mixed-mode fracture parameters in FGMs with three techniques:  $J_k$ -integral method, the displacement correlation technique and the modified crack-closure integral method. The same authors [2] used the interaction integral method for evaluation of mixed-mode SIFs in FGMs to simulate the crack growth in homogeneous and FGMs materials using the FEM. Rao and Rahman [3] used the element-free Galerkin method (EFGM) for calculating SIFs in two-dimensional FGMs of different arbitrary geometry of cracked plate. Marur and Tippur [4] studied the influence of material gradient and the crack position on the fracture parameters for edge-cracked FGM specimen. Tilbrook et al. [5] investigated the effects of gradient profile and crack geometry on crack-tip stresses and crack propagation path in FGMs. Chandran and Barsoum [6] used a generalized method to determine SIFs for cracks in FGMs,

using the CCT specimen. Kim and Paulino [7] developed the FE methodology for fracture analysis in orthotropic FGMs where cracks are arbitrarily oriented. The displacement correlation technique (DCT) and the modified crack closure (MCC) are used to evaluate SIFs in orthotropic FGMs. Chang-chun et al. [8] used the coupled method to calculate the Rice's J-integral for dynamic fracture in single edge cracked FGM panel. Eshraghi and Soltani [9] investigated weight function approach to obtain SIFs for internal central circular crack in solid cylinder.

Under mixed-mode loadings, the crack propagation path is important for fracture behaviors analysis. In the literature, a number of fracture criteria have been developed by many researchers, for example: the maximum circumferential stress (MCS) criterion proposed by Erdogan and Sih[10], the maximum energy release rate (MERR) criterion based on Griffith's theory [11], the strain energy density factor (SEDF) criterion introduced by Sih[12, 13] and the crack-tip opening displacement (CTOD) criterion developed By Sutton et al. [14].

The objective of this study is to present a numerical modeling of crack propagation in FGMs. Using the APDL code [15], the displacement extrapolation method and the maximum tangential stress theory are used to determine numerically the SIFs and the crack growth direction. The finite element analysis is used to carry out this study. The defaults effect on the crack propagation path in FGMs was examined.

## 2. Determination of fracture parameters

### 2. 1 Numerical evaluation of SIFs

Several techniques are used to obtain stress intensity factors (SIFs) in homogeneous and inhomogeneous materials, such as the displacement extrapolation technique (DET), the displacement correlation technique (DCT), the  $J^*_k$  Integral and the modified crack-closure integral. In this work, the displacement extrapolation technique is investigated to evaluate the SIFs  $K_I$  and  $K_{II}$  as follows:

$$K_I = \frac{E_{tip}}{3(1+\nu_{tip})(1+k_{tip})} \sqrt{\frac{2\pi}{L}} \left[ 4(\nu_b - \nu_d) - \frac{(\nu_c - \nu_e)}{2} \right], \quad (1)$$

$$K_{II} = \frac{E_{tip}}{3(1+\nu_{tip})(1+k_{tip})} \sqrt{\frac{2\pi}{L}} \left( 4(u_b - u_d) - \frac{(u_c - u_e)}{2} \right), \quad (2)$$

where:

$E_{tip}$  and  $\nu_{tip}$  are the Young's modulus and the Poisson's ratio given at the crack-tip.  $\kappa_{tip} = (3 - \nu_{tip}) / (1 + \nu_{tip})$  for plane stress and  $\kappa_{tip} = 3 - 4\nu_{tip}$  for plane strain.

$u_n$  (n=b, c, d and e) are the nodal displacements at nodes b, c, d and e in the x and y directions, respectively.

L is the length of the singular element side.

In this study, the special quarter point finite elements proposed by Barsoum[16] are used to obtain a better approximation of the field around the crack-tip (Fig 1), where the mid-side node of the element connected to the crack-tip is moved to 1/4 of the length of this element.

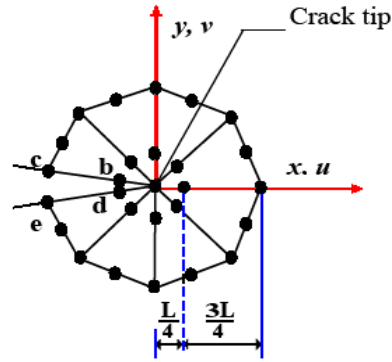

Figure 1: Singular element proposed by Barsoum, used for DET

## 2.2 Crack increment direction

Erdogan and Sih [10] were the first to propose a crack initiation criterion using the stress as a critical parameter. This criterion states that direction of crack initiation coincides with the direction of the maximum tangential stress along a constant radius around the crack tip so it is called the maximum tangential stress (MTS) criterion. It can be stated mathematically as:

$$\begin{cases} \frac{\partial^2 \sigma_\theta}{\partial^2 \theta} < 0 \\ \frac{\partial \sigma_\theta}{\partial \theta} = 0 \end{cases} \quad (3)$$

$$\tan^2 \frac{\theta}{2} - \frac{\mu}{2} \tan \frac{\theta}{2} - \frac{1}{2} = 0 \quad (4)$$

$$-\frac{3}{2} \left[ \left( \frac{1}{2} \cos^3 \frac{\theta}{2} - \cos \frac{\theta}{2} \sin^2 \frac{\theta}{2} \right) + \frac{1}{\mu} \left( \sin^3 \frac{\theta}{2} - \frac{7}{2} \sin \frac{\theta}{2} \cos^3 \frac{\theta}{2} \right) \right] < 0 \quad (5)$$

Where 
$$\mu = \frac{K_I}{K_{II}}$$

$K_I$  and  $K_{II}$  are respectively the SIFs corresponding to mode I and mode II loading. Eq. (4) and (5) can be solved for  $\theta$  such that  $\theta = \theta_0$ , which is the predicted crack initiation angle.

## 3. Strategy of crack modeling

In this paper, the APDL code has been employed for creating the program to simulate the mixed-mode crack propagation in FGMs. The displacement extrapolation technique and the MTS theory are used, to determine the SIFs and the crack direction.

The crack propagation in FGMs is characterized by successive propagation steps performed without user interaction. Fig. 2 illustrates the Flow-chart of the prepared APDL code based on the combination of the FE analysis and MTS approach.

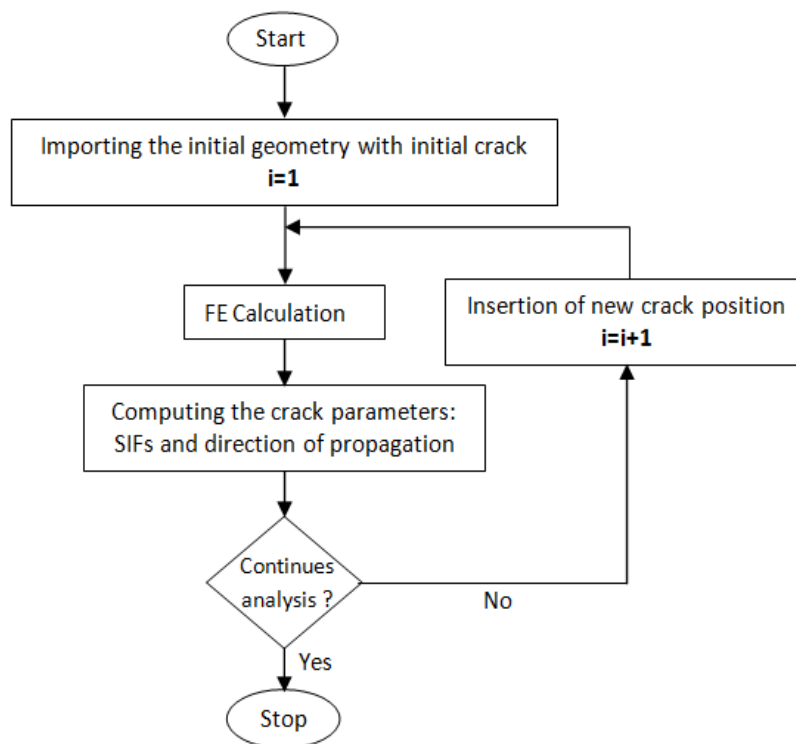

Figure 2: A flowchart of the crack propagation simulation in FGMs

#### 4. Numerical results and discussion

##### 4.1 FE evaluation of SIFs

For this problem, the geometry of the single edge cracked FGM plate with an initial crack of length  $a$  is considered for 2-Dimensional FE analysis (Fig. 3a). This geometry was originally investigated by Erdogan and Wu [17], and it is one of the few analytical solutions available for fracture in FGMs.

The plate is subjected to uni-axial loading at the both ends. The elastic modulus for FGMs plate was assumed to follow an exponential function given by:

$$E(x) = E_1 \exp(\lambda x); \quad 0 \leq x \leq w; \quad (6)$$

with  $E = E_1(0)$ ,  $E = E_2(w)$ , and  $\lambda = \ln(E_2/E_1)$ .

In this investigation, the following data were used under plane strain condition:

$$\sigma = 1, E_1 = 1; E_2/E_1 = (0.1, 0.2, 1, 5 \text{ and } 10); \nu = 0.3; a/w = 0.2, 0.3, 0.5 \text{ and } 0.6; L/w = 8.$$

Fig. 3b shows the mesh discretization of cracked FGMs plate with 710 elements and 2241 nodes. The special quarter point finite elements proposed by Barsoum are used for modeling the singular field around the crack-tip (Fig. 4b).

Fig. 4 shows the variation of normalized SIFs  $(K_I/\sigma(\pi a))^{0.5}$  vs.  $E_2/E_1$  obtained by DET under plane strain condition and compared with the numerical results obtained by Chen et al. [18] using the element free Galerkin (EFG) method and Kim and Paulino [19] using J\*-Integral method and the displacement correlation technique (DCT), respectively. The obtained results indicate good agreement between our results and other author's solution for this example.

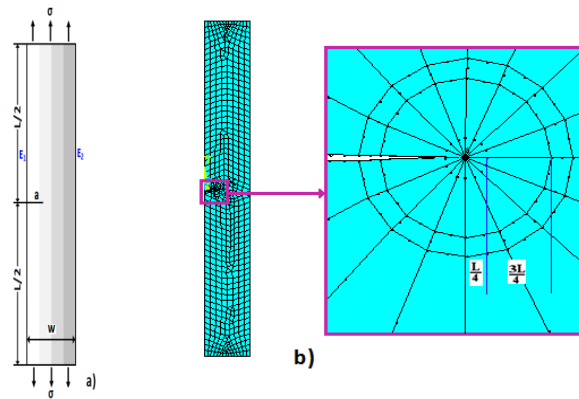

Figure 3: (a) Geometry and boundary conditions of FGM plate; (b) Singular element around the crack tip ( $a/w=0.2$ )

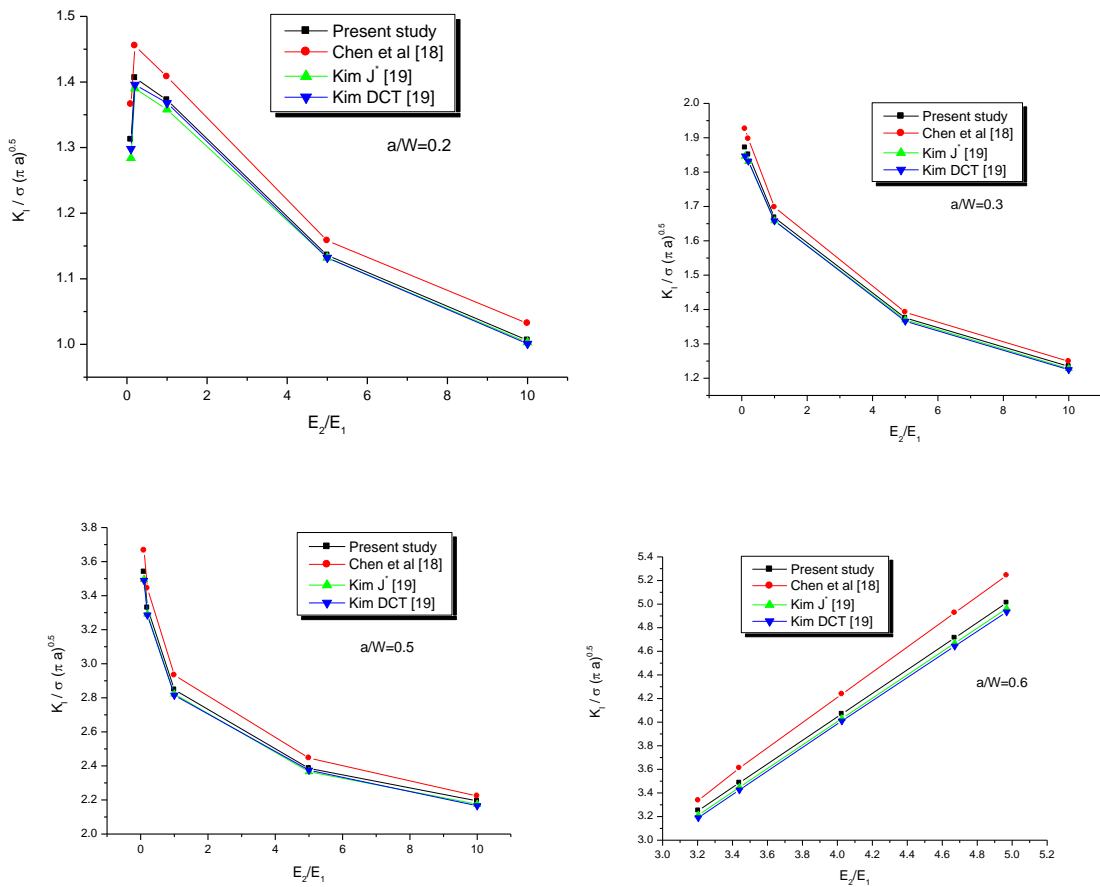

Figure 4: Normalized SIFs for edge cracked FGM plate for :  $a/w = 0.2, 0.3, 0.5$  and  $0.6$

## 4.2 Crack propagation simulation in FGM

In order to show the robustness of our strategy of crack propagation simulation, two examples are presented (FGM plate with an oblique pre-crack and single edge cracked plate with one hole). For these examples, the variation of the elastic modulus for FGM is modeled by Eq.6.

### 4.2.1. FGM plate with an oblique pre-crack

In the present problem, we consider a thin rectangular FGM plate with an oblique pre-crack (with  $\alpha=30^\circ$ ). This plate is submitted under uni-axial loading. A rectangular isotropic FGM plate with an oblique crack and final mesh for the first configuration of crack propagation are illustrated in Fig. 5. The numerical modeling is performed under plane stress conditions.

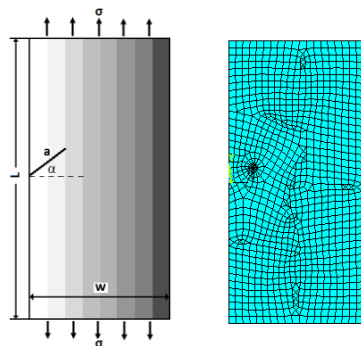

Figure 5: Geometry model and final mesh for initial configuration

Fig. 6 shows three steps for crack propagation path obtained for inclined crack in FGM plate. Fig. 7 illustrates the positions of the crack-tip during the crack extension obtained for homogeneous and FGM plates. For two materials, the crack propagated and reoriented horizontally under mode I loading.

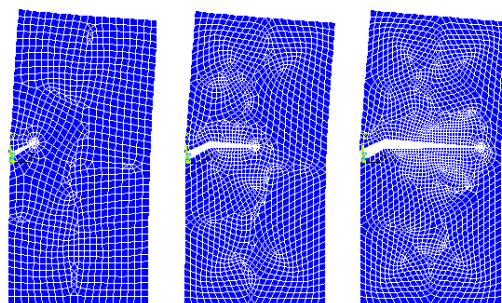

Figure 6: Crack propagation path of the inclined crack

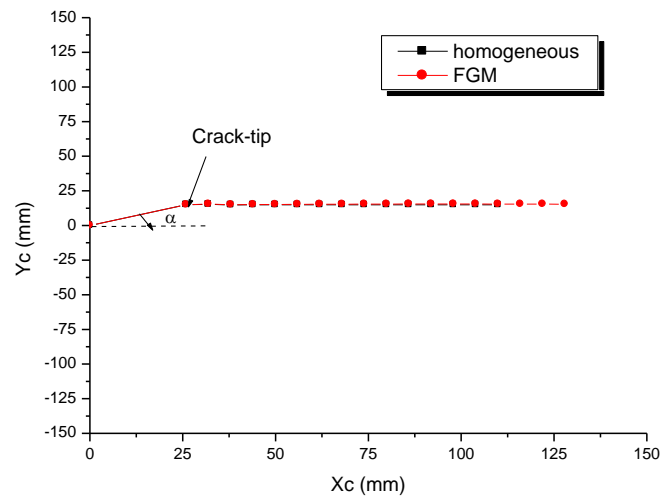

Figure 7: Positions of the crack-tip during the crack extension obtained for homogeneous and FGM

#### 4.2.2. Single edge cracked FGM plate with one hole

In order to determine the effect of a geometrical defect on the crack extension in FGMs, we present in Fig. 8a the geometry of the single edge cracked plate with one hole. This plate is simply fixed at the bottom edge and loaded by uni-axial traction along the top edge. The geometry is meshed using 8-node quadratic elements and triangular elements concentric at crack-tip (Fig 8b). The determination of SIFs, direction angle and crack growth path are made under plane stress problem.

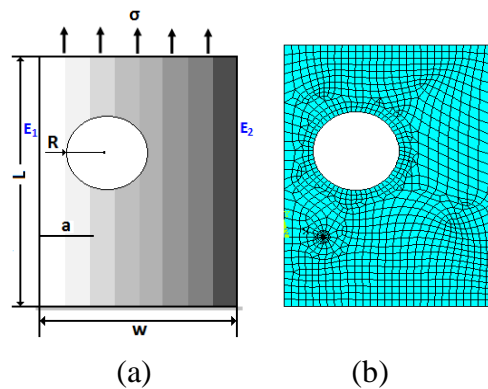

Figure 8: a) Geometry model of cracked FGMs plate with one hole and b) typical FE mesh for initial configuration

The numerical calculations obtained will compare with other results, for a homogeneous material case. Fig.9 shows the final configuration corresponding to the last position of crack-tip for the results obtained in Refs [20] and [21], and that obtained in present study. The crack propagation paths obtained are similar between them.

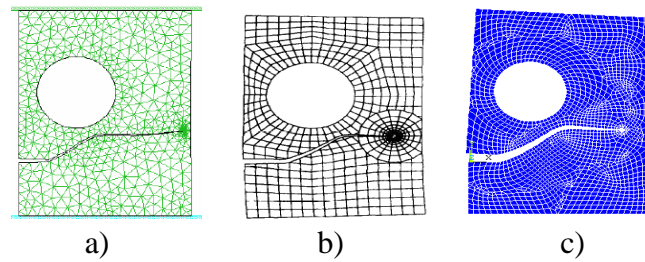

Figure 9: Final configuration corresponding to the last position of crack-tip (with  $E_2/E_1=1$ ):  
 a) Bouchard et al. [20], b) Rashid [21] and c) Present study

Fig. 10 illustrates four steps for crack extension in FGM plate. This crack would move in a straight path if there was no hole at the plate for opening-mode (mode-I) loading. However, due to the presence of the default, the crack did not follow a straight line path, but curved towards the hole as shown in Fig. 10b. This was due to the stress concentration effect; cracks are likely to initiate at a hole boundary. Once the crack-tip has moved beyond the default, the crack reoriented horizontally in the mode I loading as shown in Figs. 10c and 10d.

Fig. 11 shows the crack trajectories obtained for homogeneous and FGMs plates. One can notice the same crack propagation behavior for both plates but the two crack paths are different from each other. This may explain the fact that the stress distribution around the hole is different for the two plates, which may influence directly on the propagation trajectory.

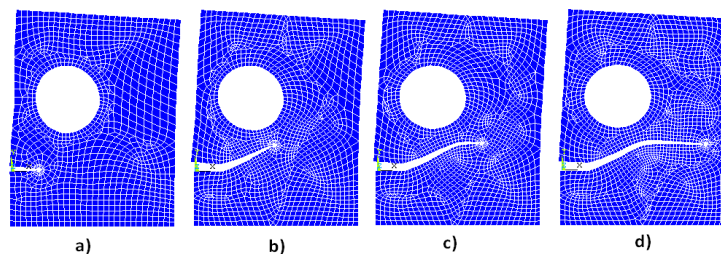

Figure 10: Four steps of crack propagation trajectory for a single edge cracked FGM plate with one hole

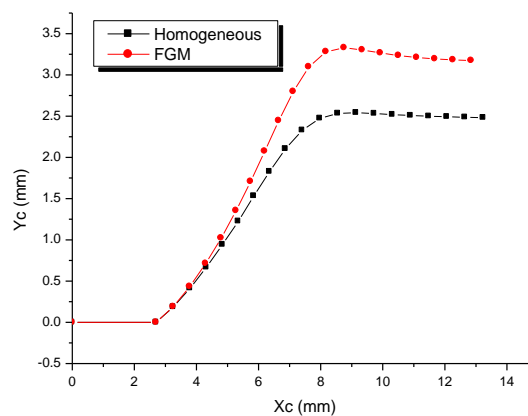

Figure 11: Positions of the crack-tip obtained for homogeneous and FGM



## 5. Conclusion

This work investigates mixed-mode crack growth in FGMs plates using the Ansys Parametric Design Language. The SIFs for a single edge cracked plate was evaluated and compared with under mode-I loading. The comparison shows that our numerical techniques is capable of demonstrating the SIF evaluation and the crack path direction satisfactorily. The methodology of crack propagation modeling proposed in this investigation has been used successfully to predict the crack path in FGM plate with holes and inclusions.

The presence of holes and inclusions in the plates disturbed the stress and strain fields providing interesting crack trajectories. The results indicated that FE analysis for fracture mechanics problems has been successfully employed for homogenous and FGM. Based on the results, it was recommended to add further development the APDL code to simulate crack propagation in orthotropic FGMs.

## References

1. J.H. Kim and G.H. Paulino. Finite element evaluation of mixed mode stress intensity factors in functionally graded materials. *International Journal for Numerical Methods in Engineering* 53 (2002) 1903-1935.
2. J.H. Kim and G.H. Paulino. Simulation of crack propagation in functionally graded materials under mixed-mode and non-proportional loading. *International Journal of Mechanics and Materials in Design* 1 (2004) 63-94.
3. B.N. Rao and S. Rahman. Mesh-free analysis of cracks in isotropic functionally graded materials. *Engineering Fracture Mechanics* (2003) 1-27
4. P. R. Marur and H. V. Tippur. Numerical analysis of crack-tip fields in functionally graded materials with a crack normal to the elastic gradient. *International Journal of Solids and Structures* 37 (2000) 5353-5370
5. M. T. Tilbrook, R. J. Moon and M. Hoffman. Finite element simulations of crack propagation in functionally graded materials under flexural loading. *Engineering Fracture Mechanics* 72 (2005) 2444-2467
6. K.S. R. Chandran and I. Barsoum. Determination of stress intensity factor solutions for cracks in finite-width functionally graded materials. *International Journal of Fracture* 121 (2003) 183-203.
7. J.H. Kim and G. H. Paulino. Mixed-mode fracture of orthotropic functionally graded materials using finite elements and the modified crack closure method. *Engineering Fracture Mechanics* 69 (2002) 1557-1586.
8. W.C. Hun, H. Peixiang and L. Ziran. Extension of J integral to dynamic fracture of functional graded material and numerical analysis. *Computers and Structures* 80 (2002) 411-416.
9. I. Eshraghi and N. Soltani. Stress intensity factor calculation for internal circumferential cracks in functionally graded cylinders using the weight function approach. *Engineering Fracture Mechanics* 134 (2015) 1-19
10. F. Erdogan F, G. C. Sih. On the crack extension in plane loading and transverse shear. *Journal of Basic Engineering* 85 (1963)519-27
11. A.A Griffith. The phenomena of rupture and flow in solids. *Philos Trans R Soc London A221* (1920) 163-98.
12. G.C. Sih. A special theory of crack propagation. Leyden: Noordhoff International Publishing; *Mechanics of fracture* 1 (1973).
13. G.C Sih. Strain energy-density factor applied to mixed mode crack problem. *International Journal of Fracture* 10, 3 (1974) 305-21.

14. M. A. Sutton, X. Deng, F. Ma F, Jr JC Newman, M. James. Development and application of a crack tip opening displacement- Based mixed mode fracture criterion. *International Journal of Solids and Structures* 37 (2000) 3591-618.
15. ANSYS, Inc. Programmer's Manual for Mechanical APDL, Release 12.1, 2009.
16. R.S. Barsoum. On the use of isoparametric finite element in linear fracture mechanics. *International Journal for Numerical Methods in Engineering*. 10 (1974) 25-37
17. F. Erdogan, BH. Wu. The surface crack problem for a plate with functionally graded properties. *ASME Journal of Applied Mechanics* 54 (1997) 449-456.
18. J. Chen, L. Wu, S. Du. A modified J-integral for functionally graded materials. *Mechanics Research Communications* 27 (2000) 301-306.
19. J.H. Kim, G.H. Paulino. Finite element evaluation of mixed mode stress intensity factors in functionally graded materials. *International Journal for Numerical Methods in Engineering* 53 (2002) 1903-1935
20. P.O. Bouchard, F. Bay, Y. Chastel, I. Tovenà . Crack propagation modelling using an advanced remeshing. *Computer Methods in Applied Mechanics and Engineering* 189 (2000) 723-742
21. M. M. Rashid. The arbitrary local mesh replacement method: An alternative to remeshing for crack propagation analysis. *Computer Methods in Applied Mechanics and Engineering* 154 (1988) 133-150.